



## OPTIFLUX 1000 Quick Start

Electromagnetic flow sensor

**KROHNE**

## General safety notes



You can find additional information on the CD-ROM provided, in the manual, the data sheet, special manuals and certificates.



Installation, mounting, commissioning, and maintenance can be performed only by trained personnel.



Responsibility for suitability and intended use of this instrument rests solely with the user.

The supplier accepts no liability for inappropriate use by the customer.

Improper installation and operation may lead to loss of warranty. Moreover, the "general terms and conditions" on the back of the bill apply, which form the basis for the sales contract.



If you have to send the device back to the manufacturer or supplier, fill out the form contained on the CD-ROM and enclose it with the device. Unless this form is completely filled out, it will unfortunately not be possible for KROHNE to perform repair or inspection.



Respect general and local electrical safety requirements.

## Scope of delivery

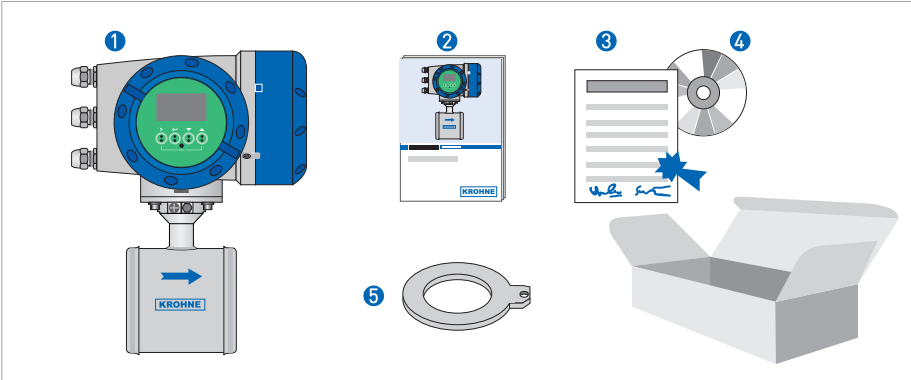

- 1 Ordered flow meter
- 2 Quick Start
- 3 Factory calibration report
- 4 CD-ROM with product documentation
- 5 Grounding rings (optionally)

## Visual check

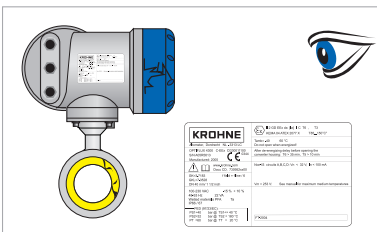

## Transport

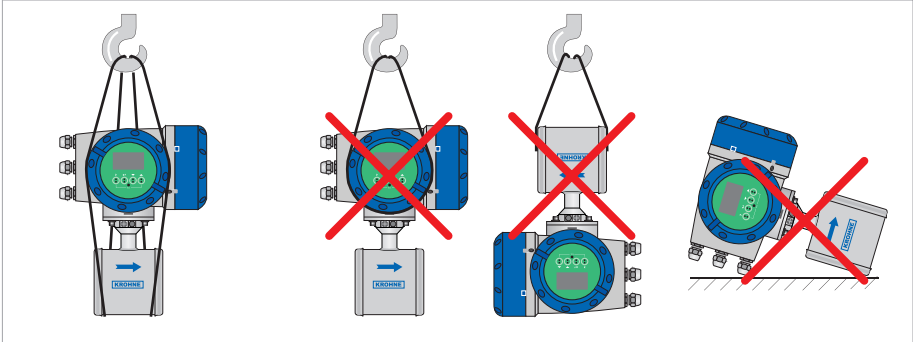

## Inlet and outlet

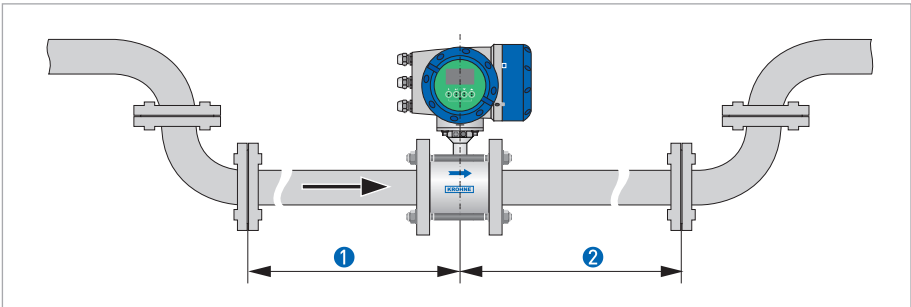

①  $\geq 5DN$

②  $\geq 2DN$

## Mounting position

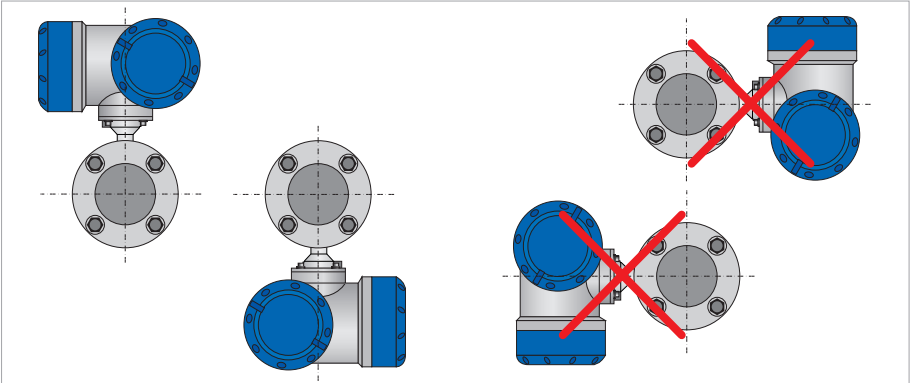

## Flange deviation

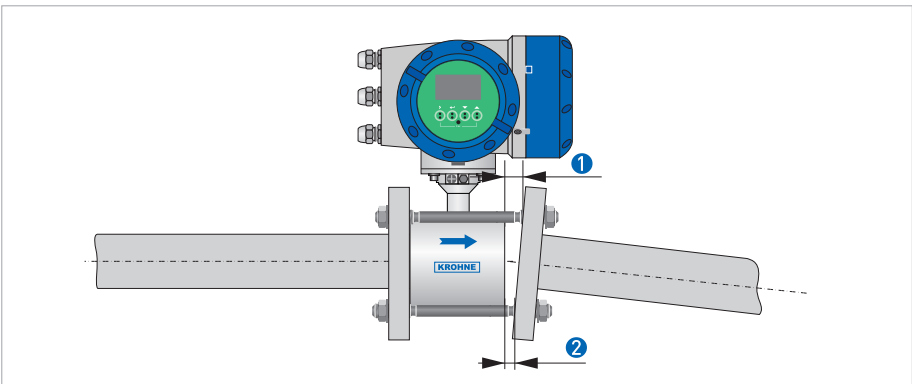

①  $L_{\max}$

②  $L_{\min}$



### CAUTION!

Max. permissible deviation of pipe flange faces:

$$L_{\max} - L_{\min} \leq 0.5 \text{ mm}$$

## T-section

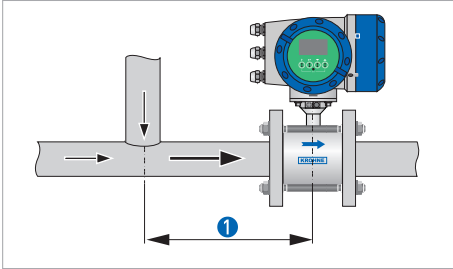

①  $\geq 10DN$

## Vibration

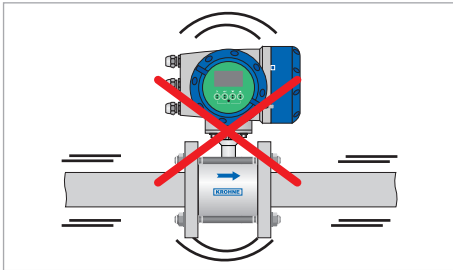

## Magnetic field

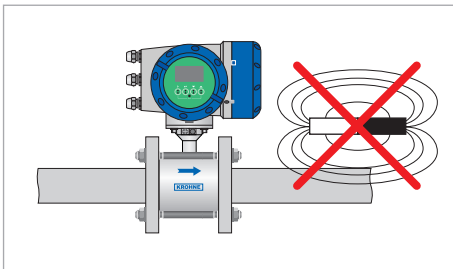

## Bends

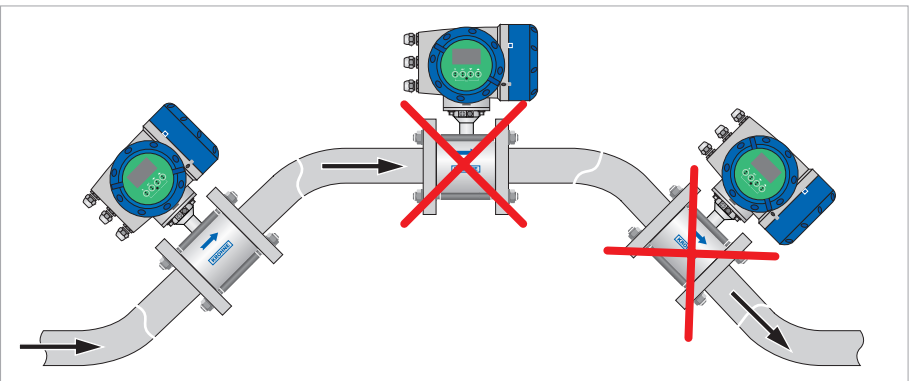
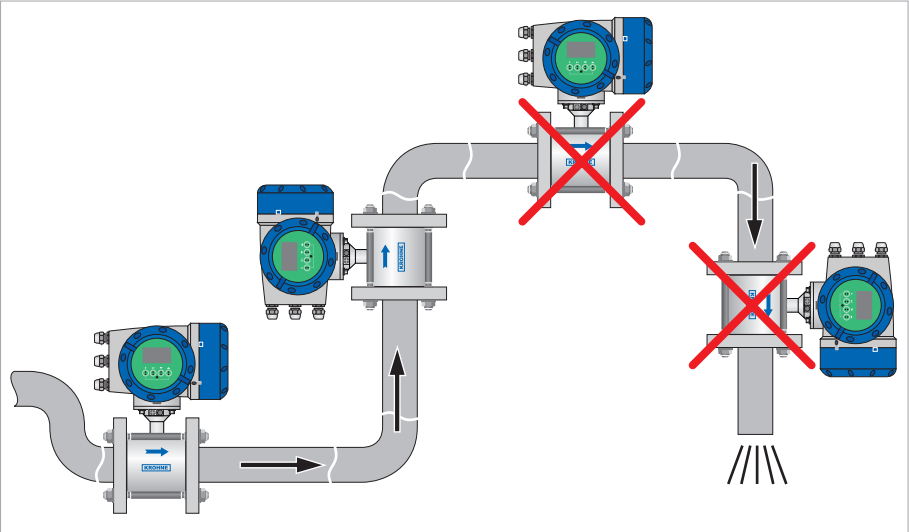

### Open discharge

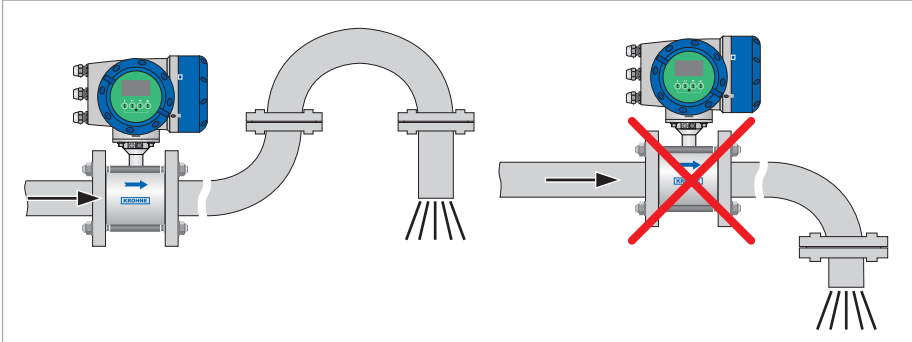

### Control valve

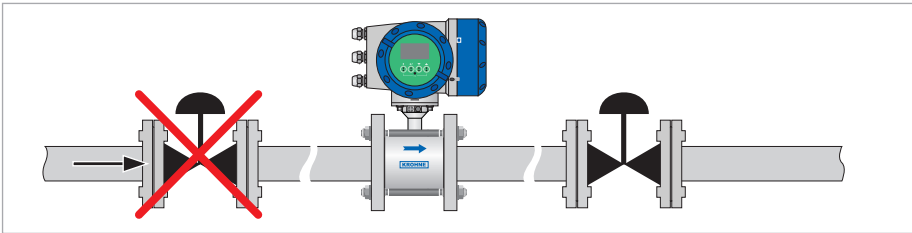

### Pump

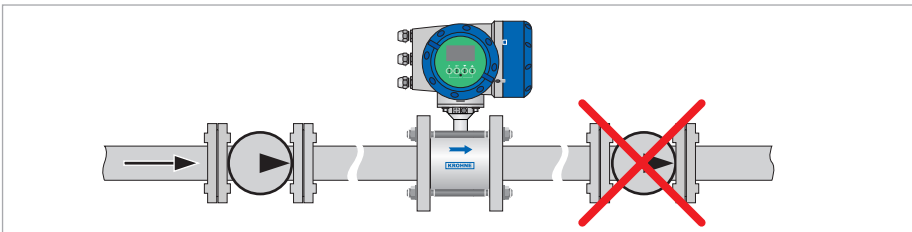

## Grounding

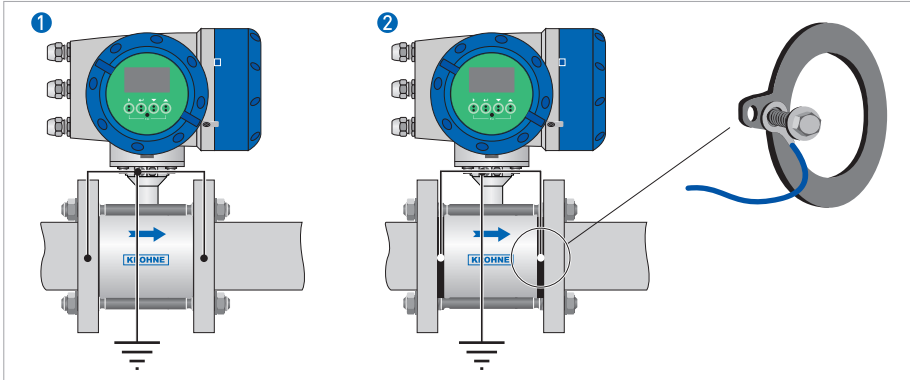

- 1 Metal pipelines, not internally coated. Grounding without grounding rings
- 2 Metal pipelines with internal coating and non-conductive pipelines. Grounding with grounding rings

## Virtual reference for IFC 300

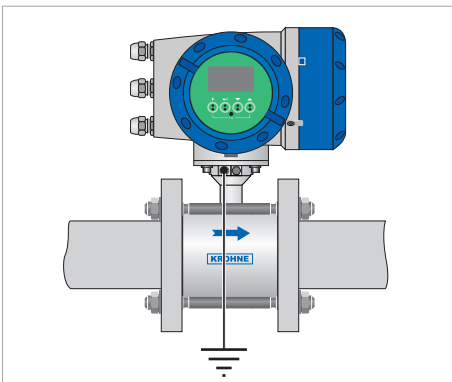

### Possible if:

≥ DN10

Electrical conductivity ≥ 200  $\mu\text{S}/\text{cm}$

## Temperatures

Temperature range	Process [°C]		Ambient [°C]		Process [°F]		Ambient [°F]	
	min.	max.	min.	max.	min.	max.	min.	max.
Separate flow sensor	-25	120	-25	60	-13	248	-13	140
Compact + IFC 300 C	-25	120	-25	50	-13	248	-13	122
Compact + IFC 010 C	-25	120	-25	40	-13	248	-13	104

## Torques and pressures

Nominal size EN 1092-1	Pipe flanges		Max. allowable operating pressure		Max. torque	
	Flange size	Pressure rating	bar	psig	Nm	ftlb
DN 10	1/2"	PN 16/40	16	230	16	12
DN 15	1/2"	PN 16/40	16	230	16	12
DN25	1"	PN 16/40	16	230	16	12
DN 40	1 1/2"	PN 16/40	16	230	25	18
DN 50	2"	PN 16/40	16	230	45	33
DN 80	3"	PN 16/40	16	230	25	18
DN 100	4"	PN 16/40	16	230	33	24
DN 150	6"	PN 16/40	16	230	82	60

Nominal size ASME B 16.5	Pipe flanges		Max. allowable operating pressure		Max. torque	
	Flange size	Pressure rating	bar	psig	Nm	ftlb
1/10...3/8"	1/2"	150/300 lb	16	230	16	12
1/2"	1/2"	150/300 lb	16	230	16	12
1"	1"	150/300 lb	16	230	15	11
1 1/2"	1 1/2"	150/300 lb	16	230	25	18
2"	2"	150/300 lb	16	230	45	33
3"	3"	150 lb	16	230	56	41
		300 lb	16	230	28	21
4"	4"	150/300 lb	16	230	36	27
6"	6"	150 lb	16	230	100	74
		300 lb	16	230	66	49

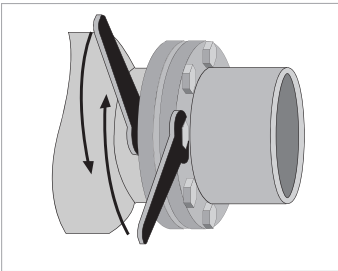

**Max. torque:**

- Step 1: approx. 50% of max. torque
- Step 2: approx. 80% of max. torque
- Step 3: 100% of max. torque given in tables above

## Contact

**KROHNE Altometer**  
Kerkeplaat 12  
3313 LC Dordrecht  
Postbus 110  
3300 AC Dordrecht, the Netherlands  
[www.krohne.com](http://www.krohne.com)