

Neptune Technology Group Inc.

1600 Alabama Highway 229
Tallahassee, AL 36078
USA

Tel: (800) 645-1892
Fax: (334) 283-7299

Neptune Technology Group (Canada) Ltd.

7275 West Credit Avenue
Mississauga, Ontario
L5N 5M9
Canada

Tel: (905) 858-4211
Fax: (905) 858-0428

Neptune Technology Group Inc.

Ejército Nacional No. 418
Piso 12, Desp. 1201-1202
Col. Chapultepec Morales
Delegación Miguel Hidalgo
11570 México, Distrito Federal

Tel: (525) 55203 5294 / (525) 55203 5708
Fax: (525) 55203 6503



NEPTUNE
TECHNOLOGY GROUP
Take Control.

neptunetg.com

HP Turbine Installation and Maintenance Guide





ARB® UTILITY MANAGEMENT SYSTEMS™ WATER | GAS | ELECTRIC

HP Turbine Installation and Maintenance Guide

This manual is an unpublished work and contains the trade secrets and confidential information of Neptune Technology Group Inc., which are not to be divulged to third parties and may not be reproduced or transmitted in whole or part, in any form or by any means, electronic or mechanical, for any purpose, without the express written permission of Neptune Technology Group Inc. All rights to designs or inventions disclosed herein, including the right to manufacture, are reserved to Neptune Technology Group Inc.

Neptune engages in ongoing research and development to improve and enhance its products. Therefore, Neptune reserves the right to change product or system specifications without notice.

Trademarks Used in this Manual

Neptune is a registered trademark of Neptune Technology Group Inc.

Other brands or product names are the trademarks or registered trademarks of their respective holders.

Neptune Technology Group Inc.

1600 Alabama Highway 229
Tallahassee, AL 36078
USA

Tel: (800) 645-1892
Fax: (334) 283-7299

Neptune Technology Group (Canada) Ltd.

7275 West Credit Avenue
Mississauga, Ontario
L5N 5M9
Canada

Tel: (905) 858-4211
Fax: (905) 858-0428

Neptune Technology Group Inc.

Ejército Nacional No. 418
Piso 12, Desp. 1201-1202
Col. Chapultepec Morales
Delegación Miguel Hidalgo

11570 México, Distrito Federal
Tel: (525) 55203 5294 / (525) 55203 5708
Fax: (525) 55203 6503

1 INSTALLING THE HP TURBINE

Installation Instructions1-1

Recommended Installation1-1

Before Operation.....1-3

2 MAINTENANCE

Adjusting the HP Turbine Calibration Vane.....2-2

 1-1/2" and 2" HP Turbines2-2

 3" - 20" HP Turbines2-3

CHAPTER 1 INSTALLING THE HP TURBINE

This chapter is designed to take you through the installation process for the High Performance (HP) Turbine.

The HP Turbine offers the widest operating range of any turbine meter on the market. To achieve optimum performance in actual service, it is essential that you follow these installation instructions.

INSTALLATION INSTRUCTIONS

All HP Turbine meters operate more accurately and reliably if installed properly. Turbine meter performance is directly related to the flow conditions of the water stream entering the meter. If the flow conditions are distorted because of upstream fittings or piping changes, a turbine meter's performance can be adversely affected.

Neptune recommends that you install all HP Turbine meters with a Neptune strainer at the meter inlet. The strainer, in addition to protecting the meter from debris in the line, also corrects the velocity profile of the flow to the meter and reduces the effects of upstream piping variations or other obstructions in the line.

When installing Neptune meters with a strainer, a minimum of four (4) pipe diameters of straight run pipe (can include components that are fully open in their normal operating position) is required upstream and downstream of the meter/strainer assembly.

If you do not use a strainer, a length of straight pipe equal to 8 to 10 diameters of the nominal pipe size should be allowed immediately upstream of the meter inlet and 2 to 4 diameters downstream. When installing an HP Turbine meter, please use the following instructions.

RECOMMENDED INSTALLATION

Figure 1.1 shows the recommended installation of an HP Turbine meter. This installation incorporates a Neptune strainer attached to the inlet of the meter and includes a downstream tee to facilitate field testing. This illustration also shows an optional bypass that provides uninterrupted service capability during periods of meter service.

As indicated previously, the Neptune strainer located upstream provides protection against meter damage from debris in the lines and virtually eliminates the effects of variations in upstream piping. Neptune specifically recommends use of a Neptune strainer of the same line size as the meter.

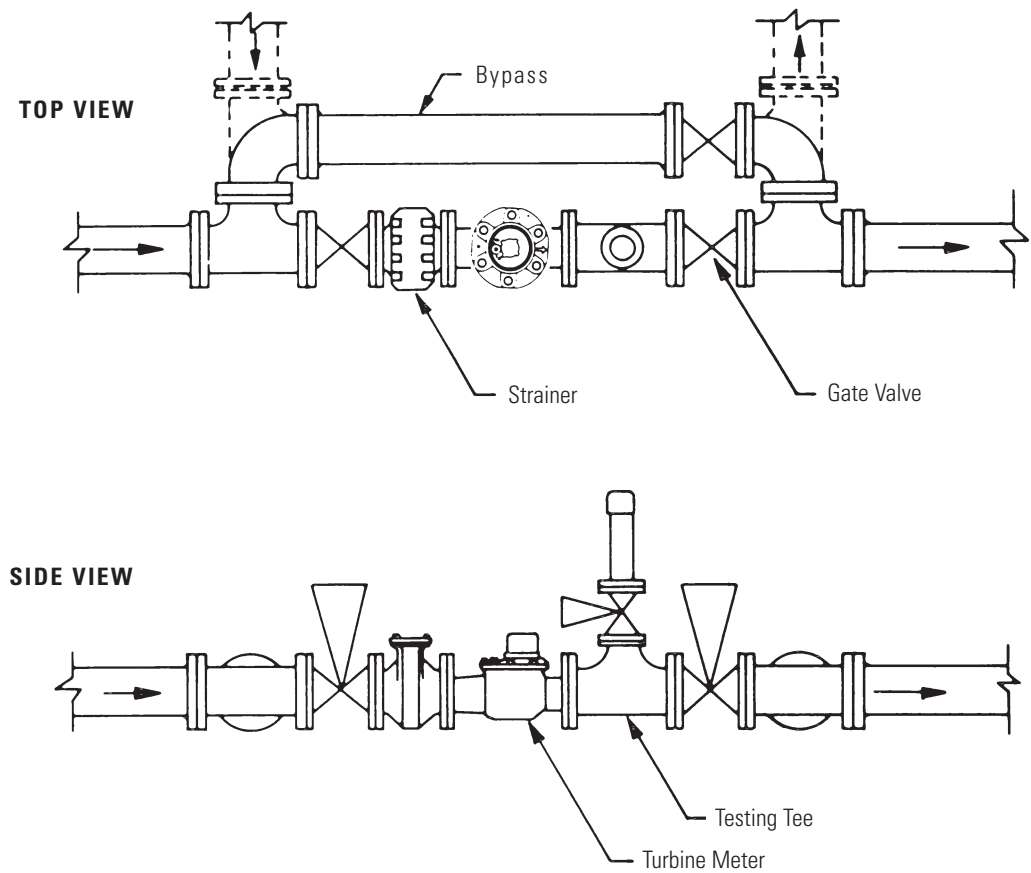

Figure 1.1 Top and Side View of the HP Turbine

This strainer design provides optimum velocity profile correction at minimum additional head loss.

The installation of the test tee can be at any convenient location where the test outlet is two pipe diameters or more downstream of the water meter outlet. We recommend this to provide a means to field test the meter without removing it from the line.



When installing HP Turbine meters, always follow normal good piping practice. Specifically, all gaskets should be centrally located on the flanges with no overlap or interference with the pipe diameter. This is particularly important at the inlet connection to the meter where a gasket protruding into the flow stream will cause unpredictable velocity conditions.

Turbine meters must operate in a completely filled line at all times. The downstream piping must always provide sufficient back pressure to maintain a full line at the meter.



Caution should be exercised to avoid air in the line, sudden flow surges, or excessive flow rates, as these conditions may cause damage to the turbine measuring element.

BEFORE OPERATION

Before putting the HP Turbine meter in service follow these steps:

- 1** With outlet-side gate valve closed, SLOWLY open inlet-side valve to pressurize meter.
- 2** SLOWLY open outlet-side gate valve until downstream line is pressurized.



After installation, it is important that you put the the upstream (inlet) valve in the “full open” condition during service. A partially throttled upstream valve without a strainer installed will cause flow profile distortion that will adversely affect meter accuracy. All throttling should be done ONLY on the downstream (outlet) side of the meter.

CHAPTER 2 MAINTENANCE

When maintenance is necessary, the complete Unitized Measuring Element (UME) may be quickly and easily interchanged with a factory-calibrated unit (see Figure 2.1).

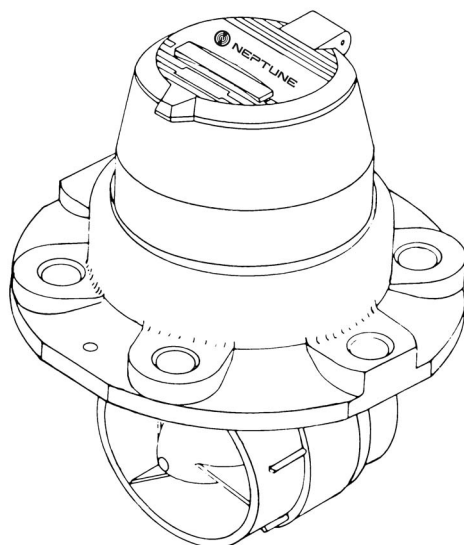

Figure 2.1 Factory-Calibrated Unit

This unit includes register, cover, and turbine measuring element.

Follow these steps:

- 1 Close valves.
- 2 Remove cover bolts.
- 3 Remove UME from maincase.
- 4 Remove old maincase gasket and replace a new gasket.
- 5 Install factory-calibrated unit into maincase.
- 6 Replace cover bolts.
- 7 Tighten cover bolts.
- 8 Open valves.

All UMEs have been factory calibrated and should not require field calibration.



Refer to meter installation instructions.

The complete UME should be returned for service to Neptune. If the customer does not have a spare unit, a factory-calibrated exchange unit may be purchased from Neptune. Neptune encourages all customers to purchase either a spare UME complete or a UME exchange contract to enable them to avoid service interruptions.

ADJUSTING THE HP TURBINE CALIBRATION VANE

Neptune equips all HP Turbine meters and UMEs with a calibration vane. Should the turbine element require field calibration, follow these steps:

1-1/2" and 2" HP Turbines

- 1 Cut seal wire and remove tamper resist cap.
- 2 Loosen lock nut by turning counter-clockwise.
- 3 Insert slotted screwdriver into slot in top of adjusting stem and
 - a Turn clockwise to decrease registration, or;
 - b Turn counter-clockwise to increase registration.



Turning the adjustment stem 3 in either direction results in approximately 1% change in registration. The full range of the calibration vane is 30 degrees (see Figure 2.2).

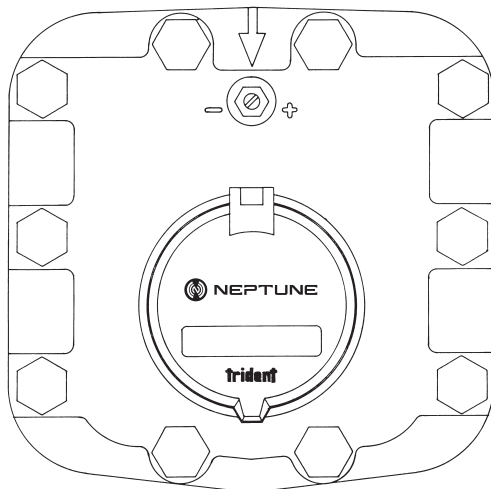

Figure 2.2 1-1/2" and 2" HP Turbines

3" - 20" HP Turbines

The calibration adjusting stem is located inside the register mounting ring for the 3"-20" HP Turbines. Should the turbine element require field calibration, follow these steps:

- 1 Remove seal pin from register and twist off register (3"-10"); or remove lead seal and unscrew register adapter screws (12"-20").
- 2 Loosen lock nut on adjusting stem by turning counter-clockwise.
- 3 Insert slotted screwdriver into slot in top of adjusting stem and
 - a Turn clockwise to decrease registration, or;
 - b Turn counter-clockwise to increase registration.



Turning the adjustment stem 15 in either direction results in approximately 1% change in registration. The full range of the adjustment stem is 180 (see Figure 2.3).

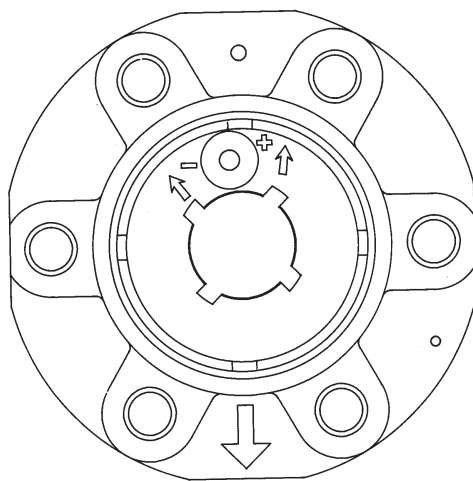

Figure 2.3 3" - 20" HP Turbines

