

High Pressure Flowmeter Parts List

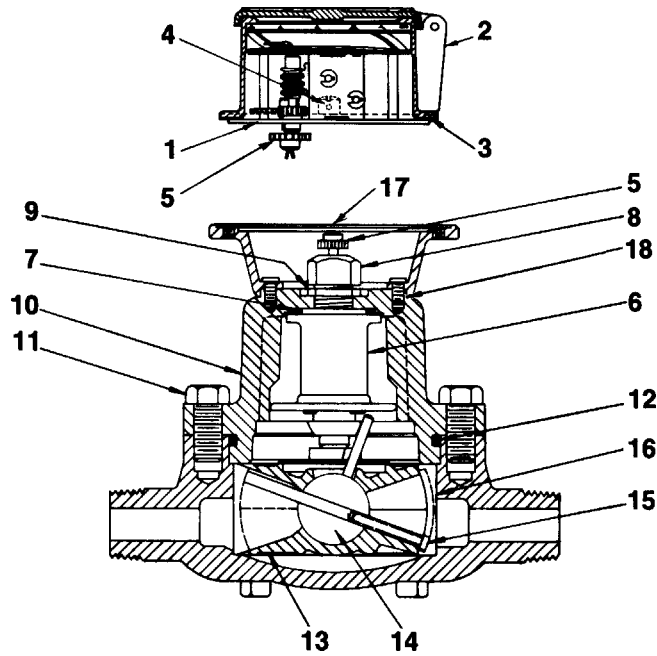



HIGH PRESSURE FLOWMETERS

Index	Part	5/8x1" Type S 5000 psi
1	Register Complete	80605-00X ¹
2	Register Box Complete	1668-001
3	Gasket, Register Box Seat	335-002
4	Screw, Register Box	9287-016
5	Change Gear	69400-999 ²
6	Gear Train Complete — 64 R	100168-002
	— 116.8 R	100168-006
7	Lead Gasket, Gear Train	4859-002
8	Nut, Stuffing Box	6217-000
9	Clamp Nut, Gear Train	34-004
10	Main Casing, Upper Half Assy.	100165-001
11	Cap Screw, Main Case	100071-079
12	O-Ring, Main Case	100139-012
13	Disc Chamber Complete	285-129
14	Disc Assembly w/Fiber Disc and half-balls	318-042
15	Thrust Roller	81-019
16	Insert, Thrust Roller Channel Insert-Plastic	100288-001
17	Meter Cover #7 Spindle (screw on)	138-030
18	Screw 1/32" x 3/8" Long Fil HD	733-001

1 Specify Units of Registration and Increments I.E. 10 US Gallons, 100 Pounds, etc.

2 Specify Diameter and Number of Teeth. (See form # TSG-310)



U.S.A./International
 1310 Emerald Road
 Greenwood, SC 29646-9558
 Tel.: Toll-Free (800) 833-3357
 (864) 223-1212
 Fax: (864) 223-0341

© 2005 Actaris U.S. Liquid Measurement Inc. 500 01/05

Specifications subject to change without prior notification.

