

# 8035

## UNIBATCH BATCH CONTROLLER



### Instruction Manual

00554592 Ind-

<b>1</b>	<b>INTRODUCTION .....</b>	<b>E-3</b>
1.1	Unpacking and Control .....	E-3
1.2	About this Manual .....	E-3
1.3	User's Responsibility for Safety .....	E-3
1.4	Electromagnetic Compatibility .....	E-3
<b>2</b>	<b>SPECIFICATION .....</b>	<b>E-4</b>
2.1	Type Specification .....	E-4
2.2	Design and Measuring Principle .....	E-5
2.3	Dimensions Electronic housing 8035 Batch controller .....	E-6
2.4	Technical Data .....	E-7
<b>3</b>	<b>INSTALLATION .....</b>	<b>E-8</b>
3.1	Installation Guidelines .....	E-8
3.2	Process Mounting .....	E-9
3.3	General electrical connection .....	E-9
3.4	Electrical Wiring .....	E-10
<b>4.</b>	<b>OPERATION AND CONFIGURATION .....</b>	<b>E-12</b>
4.1	Controller operating and Control elements .....	E-12
4.2	Description of the Dosing Options .....	E-13
	4.2.1. «LOC.MANU» Option .....	E-13
	4.2.2. «LOC.MEM» Option .....	E-13
	4.2.3. «MEM+MANU» Option .....	E-13
	4.2.4. «EXT.MEM» Option .....	E-14
	4.2.5. «EXT.[T]» Option .....	E-15
4.3	Main menu .....	E-16
	4.3.1. Dosage in manual mode .....	E-16
	4.3.2. Dosage in automatic mode .....	E-17
	4.3.3. Dosage proportional to a pulse duration .....	E-18
	4.3.4. Display of flow rate and the initial preset volume during the dosage .....	E-18
	4.3.5. Pause / reset function .....	E-19
4.4.	Calibration Menu .....	E-20
	4.4.1. Language .....	E-20
	4.4.2. Measurement units .....	E-21
	4.4.3. K-Factor .....	E-22
	4.4.4. Dosing options .....	E-22
	4.4.5. Overfill correction .....	E-24
	4.4.6. Alarm .....	E-24
	4.4.7. Relays .....	E-25
	4.4.8. Totalizer .....	E-27
4.5.	Test Menu .....	E-27
	4.5.1. EXT.ACT. ....	E-27
	4.5.2. Check on operation of relays .....	E-28
	4.5.3. Transducer frequency readout .....	E-28
<b>5.</b>	<b>MAINTENANCE .....</b>	<b>E-29</b>
5.1	Fault prompts .....	E-29
5.2.	Transducer maintenance .....	E-30
5.3.	Default configuration of 8035 INLINE Batch controller on delivery .....	E-32
5.4	Spare Parts List .....	E-32
	<b>APPENDIX .....</b>	<b>E-33</b>
	Flow Chart (l/min, DN in mm and m/s) .....	E-33
	Flow Chart (US-gallon/min, DN in inch and Ft/s) .....	E-34

Before installing or mounting this device, please take our advice and read the entire manual thoroughly.

This will enable you to fully profit from all of the advantages offered by this product.

## 1.1 Unpacking and Control

Please verify that the product is complete and free from any damage.

Compare the type specification on the label to the following list to ensure that you have received the proper unit.

## 1.2 About this Manual

This manual does not contain any warranty statement. Please refer to our general terms of sale and delivery.

Only properly-trained staff should install and/or repair this product. If difficulties should occur at the time of installation, please contact your sales office for assistance.

## 1.3 User's Responsibility for Safety

It is the user's responsibility to select a controller model that is appropriate for the application, install it properly, and maintain all components. Special attention must be paid to the chemical resistance of the sensor against the fluids which are directly contacting the product.



**This symbol appears in the manual to call special attention to instructions that affect the safe installation, function and use of the product.**

## 1.4 Electromagnetic compatibility

This device conforms to the EMC-Directive of the European Community 89/336/EEC. In order to comply with this directive, the wiring instructions must be followed.

## 2 SPECIFICATION

## BATCH CONTROLLER 8035

### 2.1 Ordering table of the Batch controller

The batch controller 8035 consists of an S030 fitting which houses the paddle-wheel and an electronic module SE35, specially designed to be installed on the fitting.

Use a separate order code for the S030 Fitting.

<b>Version</b>	<b>SE 35</b>	<b>Cable input</b>	<b>Order code</b>
Power Supply	115-230 VAC		
2 totalizers,	2 relays	2 x G 1/2" reductions	553011

### 2.2 Design and Measuring Principle

#### Design

The Batch Controller 8035 Inline consists of an electronic IP65 housing 8035 set by quarter turn on the fitting S030. The electronic housing integrates the electronic board with display, programming keys and a transducer. The paddle-wheel is mounted in the fitting.

The transducer component converts the measured signal and displays the actual value. The output signals are provided via two cable glands.

#### Measuring and Dosing Principle

When liquid flows through the pipe, 4 magnets inserted in the paddle-wheel set in rotation produce a measuring signal in the transducer.

The frequency modulated induced voltage is proportional to the flow velocity of the fluid. A conversion coefficient, specific to each pipe (size and material) enables the conversion of this frequency into flowrate. This coefficient (Factor-K in pulse/liter) is available in the instruction manual of the inline fitting (S030).

The controller 8035 Batch is mounted on a pipe in series with the valve. The 8035 unit measures the flow, calculates the volumes, and operates the valve(s) according to the selected program (see § 4).

The controller electronic module 8035 Batch requires a power supply of 230/115 VAC.

#### Dosing options

Following dosing modes are available

##### I) Local dosing command:

a) The user enters the volume to be measured and initiates the dosing from the keypad. ("LOC.MANU") (§ 4.3.1)

b) Local dosing with preset volumes. Selection of a pre-set volume and activation of the process from the keypad. ("LOC.MEM"). (§ 4.3.2)

c) Combination from "LOC.MANU" and "LOC.MEM" options. activated from the keyboard ("MEM+MANU") (§ 4.3.1 + § 4.3.1).

##### II) Remote dosing command:

a) Dosing controlled by binary inputs issued from a PLC. Each pulse controls the dosing of a preselected volume. ("EXT.MEM") (§ 4.3.4)

b) Automatic dosing controlled by the pulse duration. The distributed volume is directly proportional to the pulse duration ("EXT . [T]") (§ 4.3.3)

## 2 DESCRIPTION

## BATCH CONTROLLER 8035

### 2.4 Batch Controller 8035 INLINE external dimensions (mm)

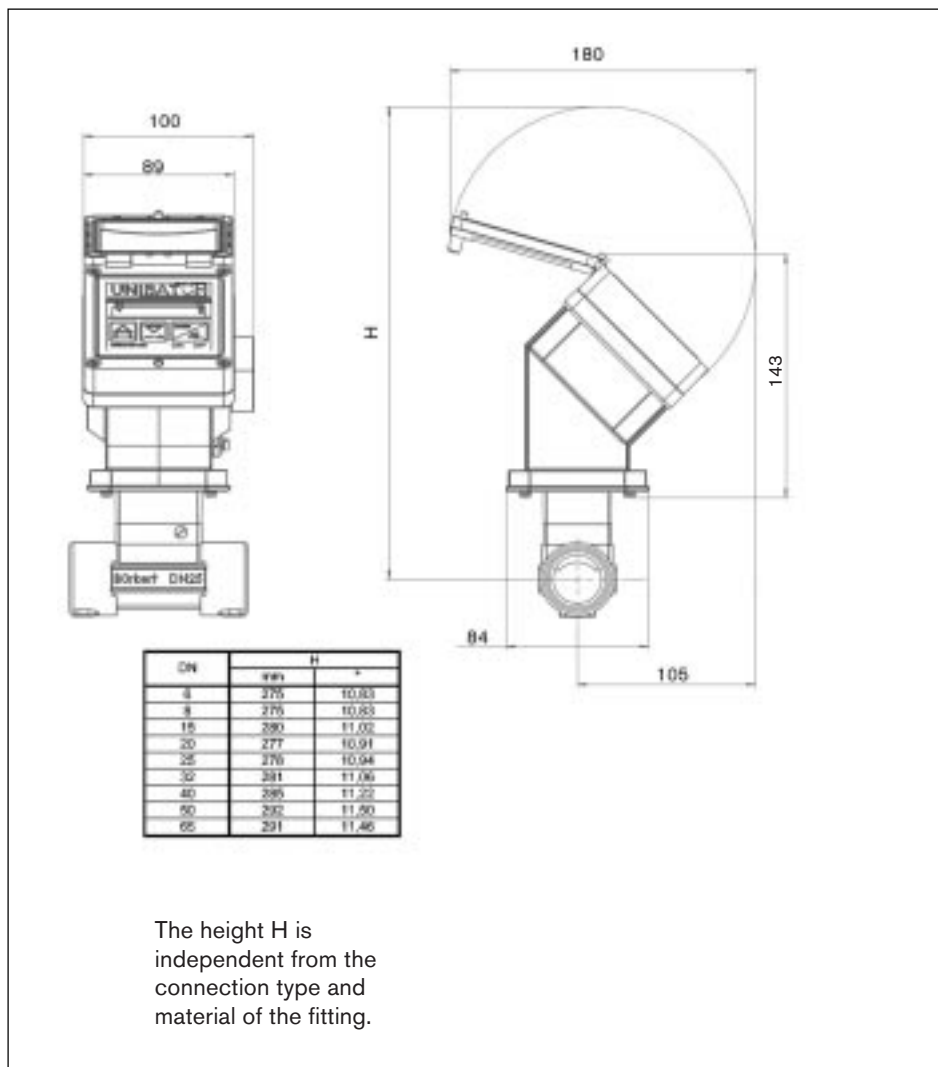
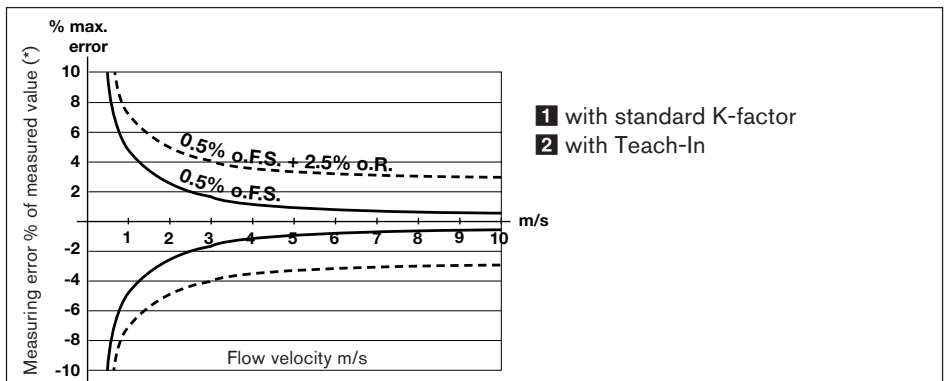

Fig. 1 Batch Controller 8035 INLINE external dimensions

## 2.4 Technical Data

Pipe diameter	from DN 06 to DN 65 (1/4" to 2"1/2)
Measuring range	0,3 to 10 m/s (1.0 to 32.8 ft/s)
flow range	as from 3 l/min (DN15 pipe, 0.3 m/s flow velocity)
flow range	as from 0.8 gpm (1/2" pipe, 1.0 ft/s flow velocity)
<b>Plastic fitting</b>	PN10 Fluid temperature max: PVC: 50 °C (132°F); PP: 80 °C (176°F); PVDF: 100 °C (212°F)
<b>Metal fitting</b>	PN16 Fluid temperature max: 100 °C (212°F)
Ambient temperature	0 to 60 °C (32 to 140 °F)
Storage temperature	0 to 60 °C (32 to 140 °F)
Relative humidity	80 %, non condensated
Enclosure	IP65
Measuring error	1. With In-line calibration (Teach-In): ≤ ± 0.5% o.F.S. (at 10 m/s) * 2. With standard mean K-Factor: ≤ ± (0.5% o.F.S. + 2.5% o.R.) *
Linearity	≤ ± 0.5% o.F.S. (at 10 m/s) *
Repeatability	0.4% o.R. *
Display	15 x 60 mm LCD 8 digits, alphanumeric, 15 segments, 9 mm high
Sensor holder	PVDF, PP, PVC, SS 316L (1.4404), Brass
Paddle-wheel	PVDF
Axis and bearing	ceramic
O-rings	FPM
Electronics housing	PC; Front plate foil polyester
Voltage supply	12...30 VDC (230 VAC power supply as option )
Binary inputs	4 inputs, 5...30 VDC
Relay output	2 relays, 3 A, 220 V, freely adjustable

(\*) Under reference conditions i.e. measuring fluid water, ambient and water temperature 20°C, applying the minimum inlet and outlet pipe straights, matched pipe dimensions.  
o.F.S. = of standard Full Scale (10 m/s) - o.R. = of Reading



Measuring error with/without Teach-In

## 3.1 Installation Guidelines



**The controller 8035 Batch INLINE can only be used to measure pure, liquid and water-like fluids (solids content  $\leq 1\%$ , viscosity max. 300 cSt with on-line calibration).**

Observe pressure-temperature dependence according to the respective fitting materials.

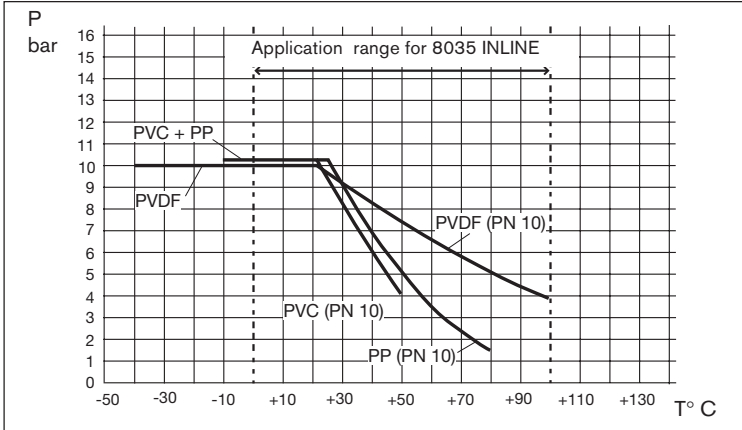

Fig. 2 Pressure-Temperature-Diagram

### Fitting S030 installation guidelines

The pipe must be completely filled with the liquid, i.e. air bubbles must not be present. The flow sensor is not designed for gas flow measurement.

The device must be protected from constant heat radiation and other environmental influences, such as direct exposure to sunlight.

The recommended upstream and downstream straight pipe length should respect 10xDN in and 3xDN out. According to pipe's design, necessary distances can be bigger or use a flow straightener to obtain the best accuracy. For more information please refer to EN ISO 5167-1.

The flow sensor can be installed in either horizontal or vertical pipe.

The suitable pipe size is selected using the diagram on the end pages. Pressure and temperature ratings must be respected according to the selected fitting material. (see fig. 2).

We recommend to install the transmitter vertically, as shown in the following schematic:

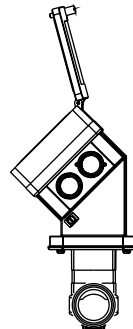

In other mounting positions, strong vibrations could damage the transmitter.

## 3.2 Process mounting

The flow controller 8035 Batch can be easily installed in pipes using the specially designed fitting system S030 INLINE.

1. The fitting **1** must be installed into the pipe according to the installation specifications (see § 3.1).
2. Fasten the electronic housing **2** to the fitting using the bayonet connection, and turn by 30°.
3. Tighten the electronic housing with the screw **3**.
4. Wire according § 3.4.

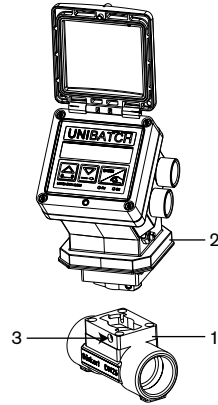

Fig. 3 Batch controller, mounting diagram

## 3.3 General Electrical Connection



- **Do not open and wire the transmitter with the power supply connected.**
  - **It is advisable to put security devices on :**  
**Power supply: Fuse (300 mA) and an interrupter**  
**Relay: 3A max. fuse and circuit breaker (depending on application).**
  - **Do not apply both a dangerous voltage and a very low safety voltage to the relays.**
- 
- Use cables with a temperature limit of 80°C minimum.
  - For normal operating conditions the measuring signal can be transmitted by a shielded cable of 0.75 mm<sup>2</sup> cross section.
  - The line must not be installed in combination with carrying lines with a higher voltage or frequency.
  - If a combined installation cannot be avoided, a minimum space of 30 cm (1 ft) should be respected.
  - The cable diameter must be between 6 and 12 mm;  
If 2 cables are needed, use the supplied multiway seal and 4-mm diameter cables.
  - The power supply must be regulated.

- Ensure the equipotentiality of the installation (power supply - transmitter):
  - The various earth spots in the installation have to be connected together to eliminate the potential differences that may occur between different earthes.
  - Observe faultless grounding of the cable shielding.

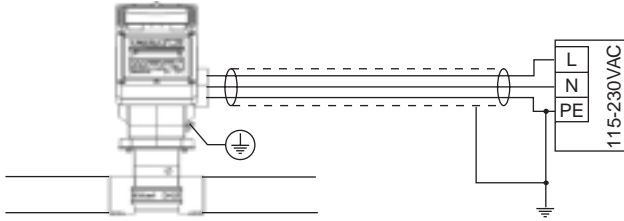

## 3.4 Electrical connection 8035 Batch

The connections are made via the two cable glands.

Remove cover, pull the cable through a cable gland and wire according to following pin assignment and following figure:

- 1: Binary input 1
- 2: Binary input 2
- 3: Binary input 3
- 4: Binary input 4
- 5: Indicator lamp output (Transistor Open Collector)
- 6: Common (binary inputs and outputs)
- 7: L+ (12...30 VDC)
- 8: L-
- 9: Earth
- 10: Relay 2
- 11: Relay 2
- 12: Relay 1  Main valve
- 13: Relay 1  see § 4.4.7

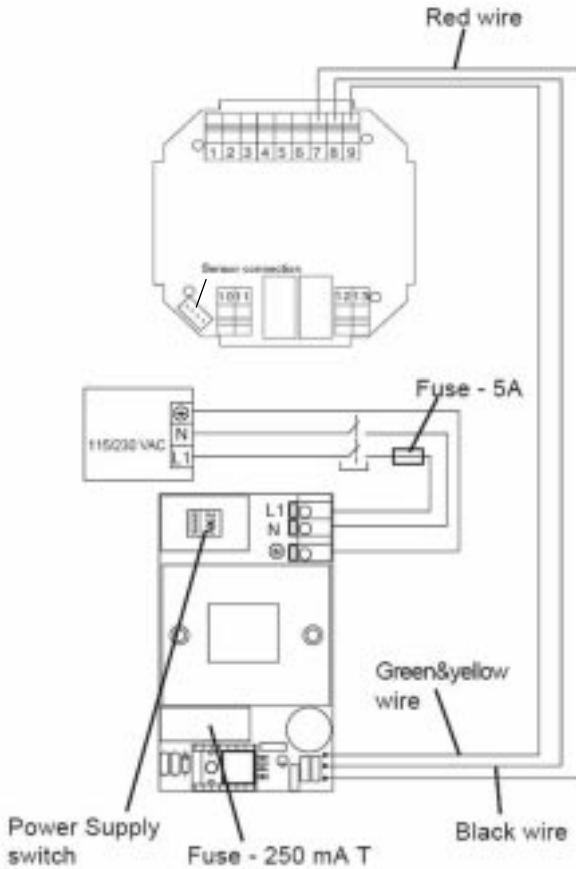

**Important:** The 230/115 VAC version doesn't allow the driver unit power supply to be used for the binary data inputs and the indicator lamp output (open collector).

The operation is classified according to three levels.

### A) Display

This menu allows the user to control the dosing by the keypad (start, pause, reset, stop); using the LCD display, he can monitor the flow rate and the initial preset volume throughout the dosing operation. The readings of the main counter and the daily counter are displayed within this menu. The daily counter can be set to zero.

### B) Parameter Definition

This menu enables the setting of dosing parameters (languages, measurement units, equipment, K factor, dosing option, overflow correction, alarm and relay thresholds). Simultaneous resetting of the two counters is carried out within this menu.

### C) Testing

This menu enables the user to check the binary inputs (remote control) and to simulate the operation of the relays.

It also measures the rotation frequency of the paddle wheel.

## 4.1 Controller Operating and Control Elements



**4.2 Description of Dosing Options**

Dosing options are selected within the «OPTION» sub-menu of the Calibration Menu. ( § 4.4.4.)

**4.2.1. "LOC.MANU" Option»**

When this option is selected, the prompt «BATCH M» is displayed within the main menu. It enables the generation of a volume which can be defined using the keypad. (see § 4.3.1.)

**4.2.2. "LOC.MEM" Option**

When this option is selected, the prompt «BATCH A» is displayed within the main menu. Generation of a volume previously entered into the memory (7 in total) from the keypad (see § 4.3.2.).

**4.2.3. "MEM+MANU" Option**

When this option is selected, the prompts «BATCH M» and «BATCH A» are displayed within the main menu.

Generation of a volume either manually or automatically. (see § 4.3.1 and § 4.3.2).

## 4.2.4 »EXT.MEM» Option

Generation of a volume previously entered into the memory (7 in total) from a remote position by using the binary data inputs (See § 4.2.2.). The following example describes the various methods of connection.

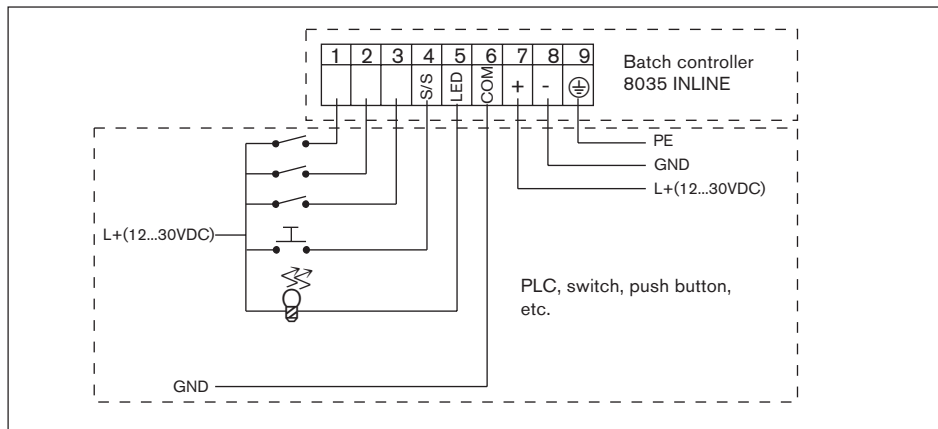

Fig. 6 Connection to a PLC

The selection of a volume from the memory (1 to 7) is carried out by encoding the binary data at inputs 1,2 and 3. The following table shows the logic value at each input to provide each of the desired seven quantities:

Volume	V1	V2	V3	V4	V5	V6	V7
Input 1	1	0	1	0	1	0	1
Input 2	0	1	1	0	0	1	1
Input 3	0	0	0	1	1	1	1

1: Input enabled (switch closed)

0: Input disabled (switch open)

Input 4: Start / Pause function (from a push button, for example).

Output 5: Transistor output (open collector)

Provides Batch controller status information. For example, it can be used to feed an indicator lamp.

The following status can be indicated:

- |                         |   |
|-------------------------|---|
| Lamp off                | No dosing in progress                   |
| Lamp on                 | Dosing in progress                      |
| Slow flashing (1 Hz)    | Pause in dosing operation               |
| Rapid flashing (3.5 Hz) | Alarm (problem during dosing operation) |

**4.2.5. «EXT. [T]» Option**

Delivery of a volume proportional to the duration of the high level on the input 1 (see § 4.3.3.). The proportional relationship is as follows:

$$X = \text{Volume} = (A \times t) + B$$

A Coefficient of proportionality (/s;...)  
 B Offset (l;...)  
 t Duration of input 1 activation (ms, s;...)  
 X Dosing volume (l;...)

Coefficients A and B entered by the user.

**Pulse specification**

$T_{\min}$ :	100 ms
$T_{\max}$ :	300 s
Definition:	5 ms
Delay between 2 pulses:	min 100 ms

Practical examples:

- **1** Filling cans of 5, 10 and 50 litres respectively. The following values can be entered:

$$A = 5 \text{ l/s}$$

$$B = 0 \text{ l}$$

The activation times for binary data input 1 for the three volumes are as follows:

Volume (l)	5	10	50
Duration (s)	1	2	10

- **2** Doses of chemical products as a function of required concentration. Volumes of 110, 120, 130, and 150 litres. The following values can be entered:

$$A = 5 \text{ l/s}$$

$$B = 100 \text{ l}$$

The activation times for binary data input 1 for the three volumes are as follows:

Volume (l)	110	120	130	150
Duration (s)	2	4	6	10

**Notes:**

- The activation time for the binary data input must always be lower than the actual filling time. A margin of safety should be allowed when choosing the coefficients A and B.
- The coefficients A and B should be chosen such that the activation times for the binary data input should be efficient. In the example **2**, one could have chosen A = 100 l/s and B = 0 l. The resulting activation times would be 1.1, 1.2, 1.3 and 1.5 seconds. In this case the distributed doses would be less accurate.

## 4.3 Main menu

Within the main menu, following readouts are available:

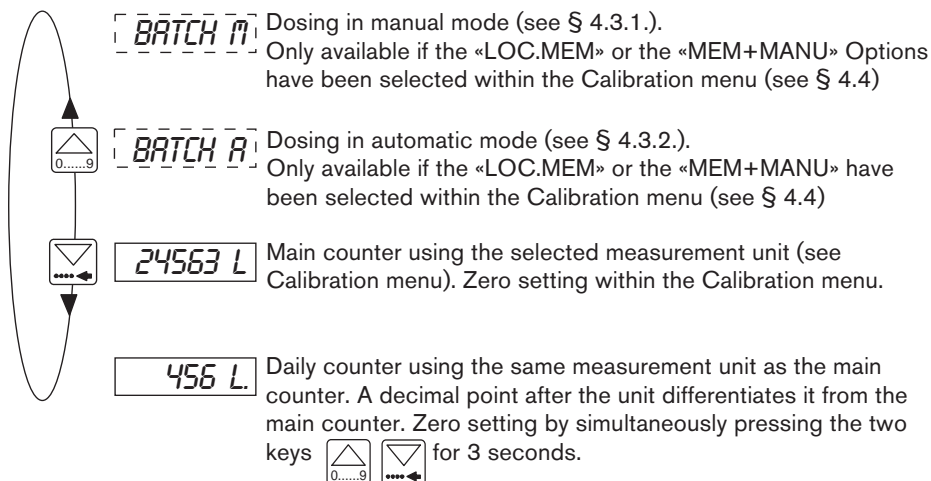

The following sub-routines describe the various dosing options together with the prompts displayed within the main menu. The GREY CHARACTERS are flashing when displayed.

### 4.3.1. Dosing in manual mode»LOC.MEM» or «MEM+MANU» Options

Generation of a volume previously entered from the keypad.

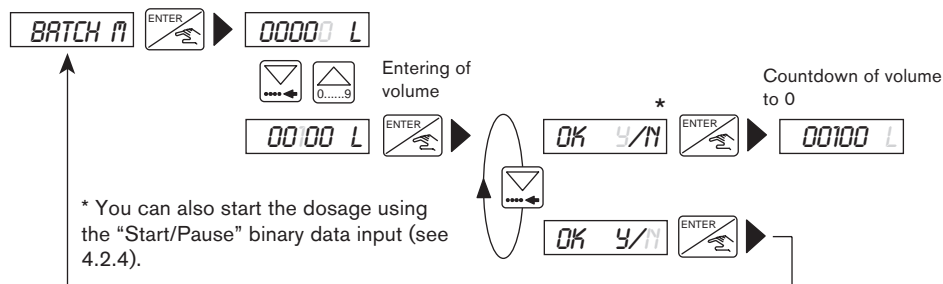

The volume must be greater than 6 pulses generated by the paddle-wheel. The entry of a zero volume forces a return to the «BATCH M» option.

The «ALARM» prompt during a dosing operation signifies a dosing problem (see § 5.1). During the measure of the selected volume, displaying the flow rate, pause, reset or stop the dosing operation. (see § 4.3.4.; § 4.3.5.) are still possible.

### 4.3.2. Dosing in automatic mode («LOC.MEM», «MEM+MANU», or «EXT.MEM» Options)

Generation of the volume from one of the 7 values previously entered into the memory. The selected volume can be initiated either from the keypad or by the binary inputs.

#### Initiating the dosing from the keypad («LOC.MEM», «MEM+MANU» Options)

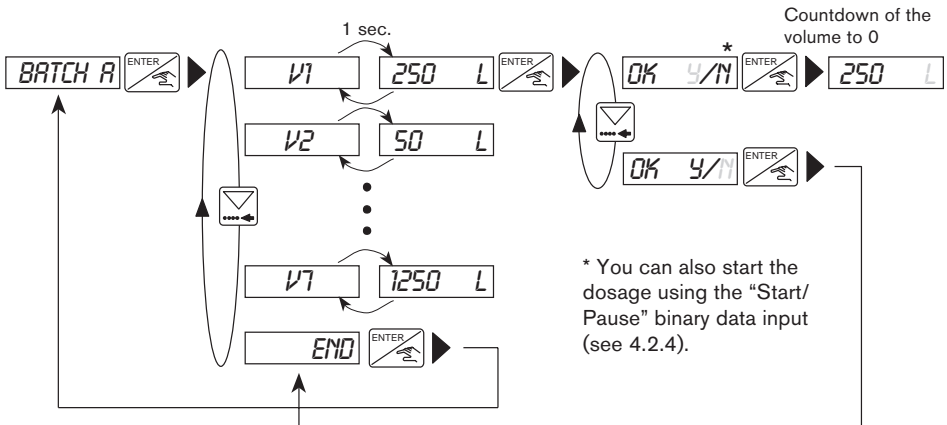

Zero quantities (from V1 to V7) will not be displayed.

#### Initiating the dosing from the binary data inputs («EXT.MEM» Option)

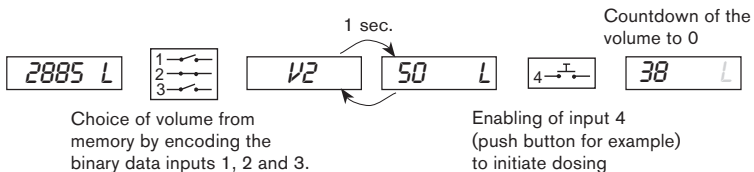

«ALARM» prompt during dosing operation: dosing problem (see § 5.1.)

During the dosing of the selected volume, it is possible to display the flow rate, to pause, to reset or to stop the operation (see § 4.3.4. and § 4.3.5)

### 4.3.3. Dosing proportional to a pulse duration («EXT.[T]» Option)

This option enables the initiation of a dosing volume proportional to the time during which binary data input 1 is enabled. The following prompts are displayed within the principal menu during the dosing operation.

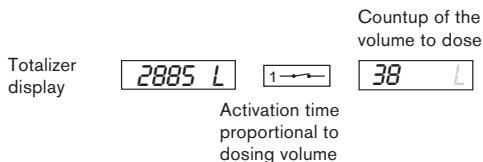
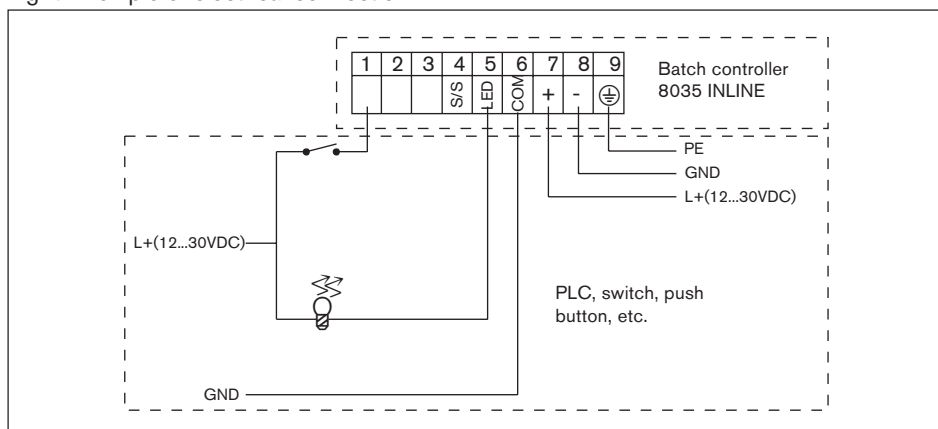



Fig. 9 Example of electrical connection



«ALARM» prompt during the dosing operation: dosing problem (see § 5.1.).

During the dosing of the selected volume, it is possible to display the flow rate, to pause, to reset or to stop the operation. These facilities are only selected on the keypad. (see § 4.3.4. and § 4.3.5)

### 4.3.4. Display of flow rate and the initial preset volume during the dosing

To display the flow rate and of the initial preset volume values during the dosing operation, press the  key briefly. This is a useful facility irrespective of the dosing option chosen.

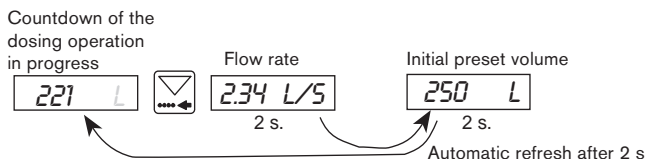

## 4.3.5. Pause / reset function

A current dosage can be momentarily or definitively stopped (except mode EXT [T]).

### a) Modes MEM+MANU, LOC.MEM, LOC.MANU :

Countdown of the dosage operation in progress

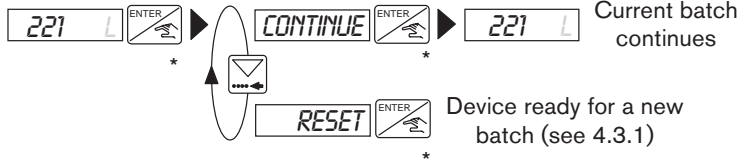

\* When in mode MEM+MANU, LOC.MEM or LOC.MANU, you can also start the dosage using the 'Start/Pause' Binary Data Input.

### b) Mode EXT.MEM :

Countdown of the dosage operation in progress

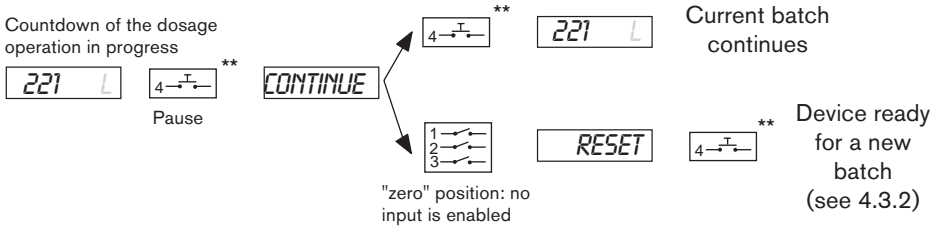

### c) Mode EXT [T] :

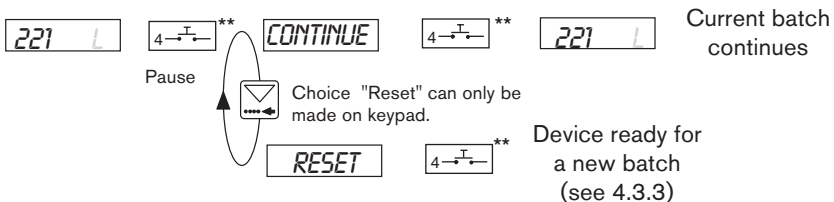

(\*\*) When in mode EXT.MEM or EXT [T], you can also press the Enter key on the keypad.

## 4.4. Calibration Menu: pressing simultaneously for 5 seconds

Within this menu, the following parameters may be set:

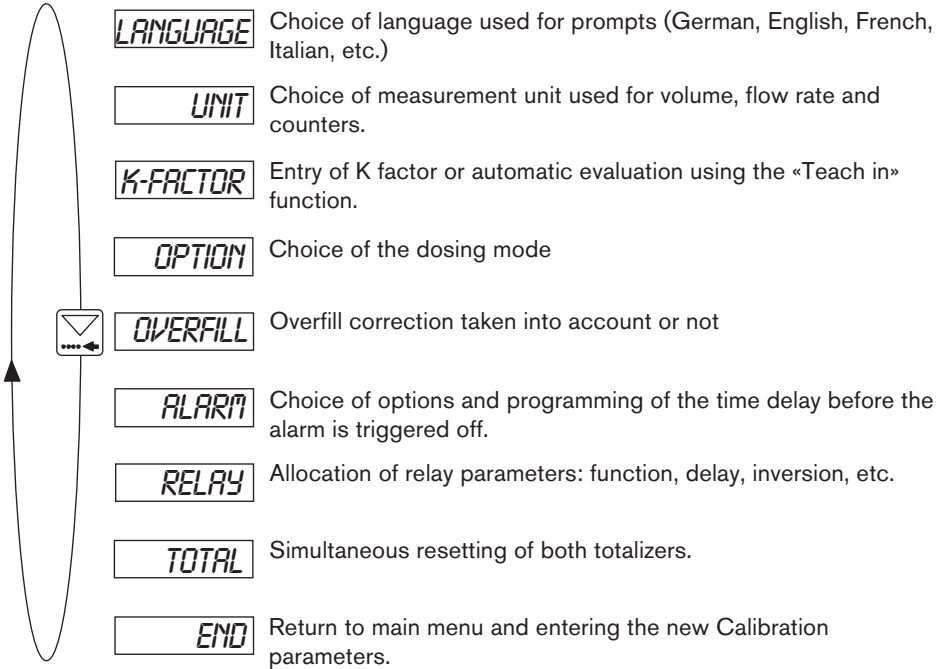

### 4.4.1 Language

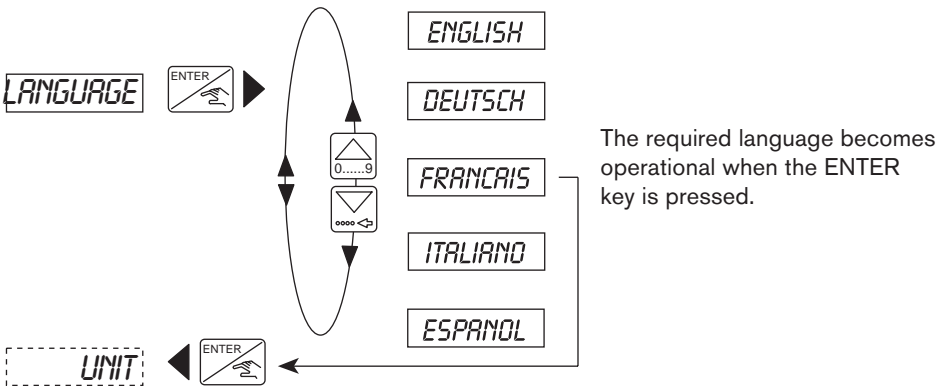

## 4.4.2 Unit

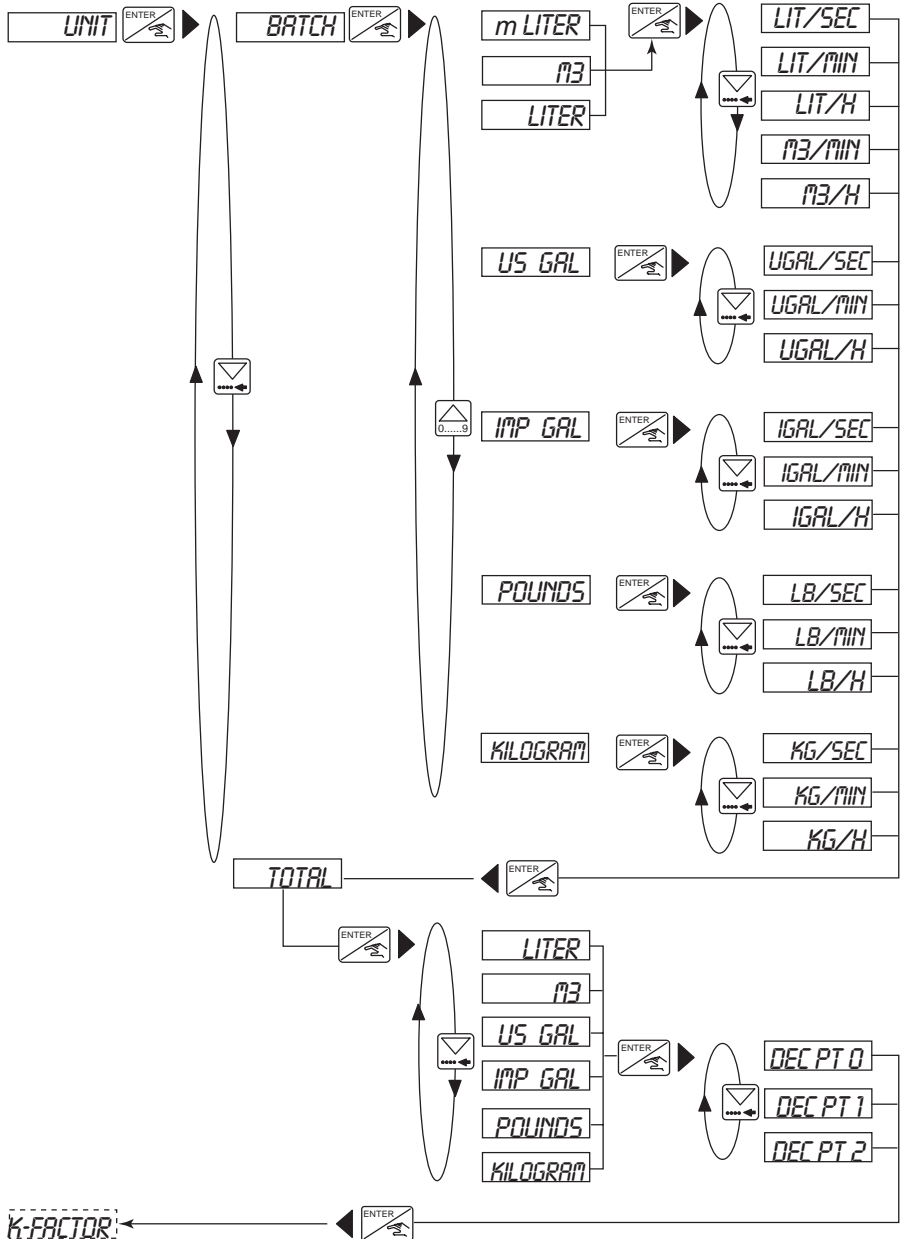

Note: Return to the main menu is only available from the «TOTAL» Sub-Menu.

## 4.4.3 K-factor

The K-factor of the fitting is entered within this menu (see instruction manual fitting S030). The "TEACH IN" function allows the practical determination of the specific K-factor. The user only needs to run a known volume through his system.

Example: In order to determine a volume as accurately as possible, the user shall fill a tank of 100 l. When the message "TEACH YES" appears, he presses the ENTER key to start the measuring procedure. The message "FILL END" (end of filling) will appear. He then switches on a pump or opens a valve. As soon as the tank is empty, he switches off the pump or closes the valve. Pressing Enter stops the measurement. The user will then be asked to enter the volume (100 l). The calculated K-factor is displayed after confirmation.

Note: The device uses the last K-factor entered or determined .

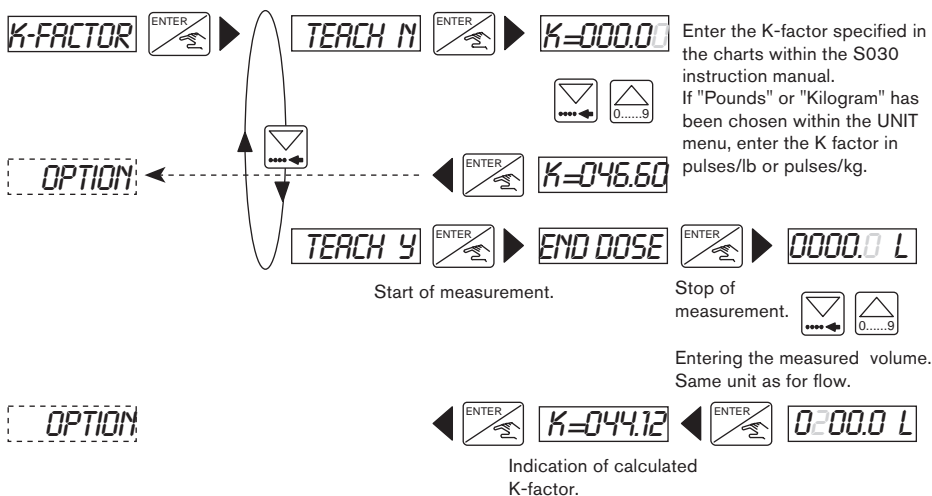

Note: A decimal point can be entered by simultaneously pressing keys . It will always be positioned to the right of the flashing digit. Three positions are possible, «00000», «0000.0» or «000.00».



### Modifying the K factor resets the totalizers.

Adjustment range for the K factor : 0,01 to 99999.



## 4.4.4. Dosing Options

Selection the dosing option from: LOC.MEM, LOC.MANU, MEM+MANU, EXT.MEM, and EXT.[T].

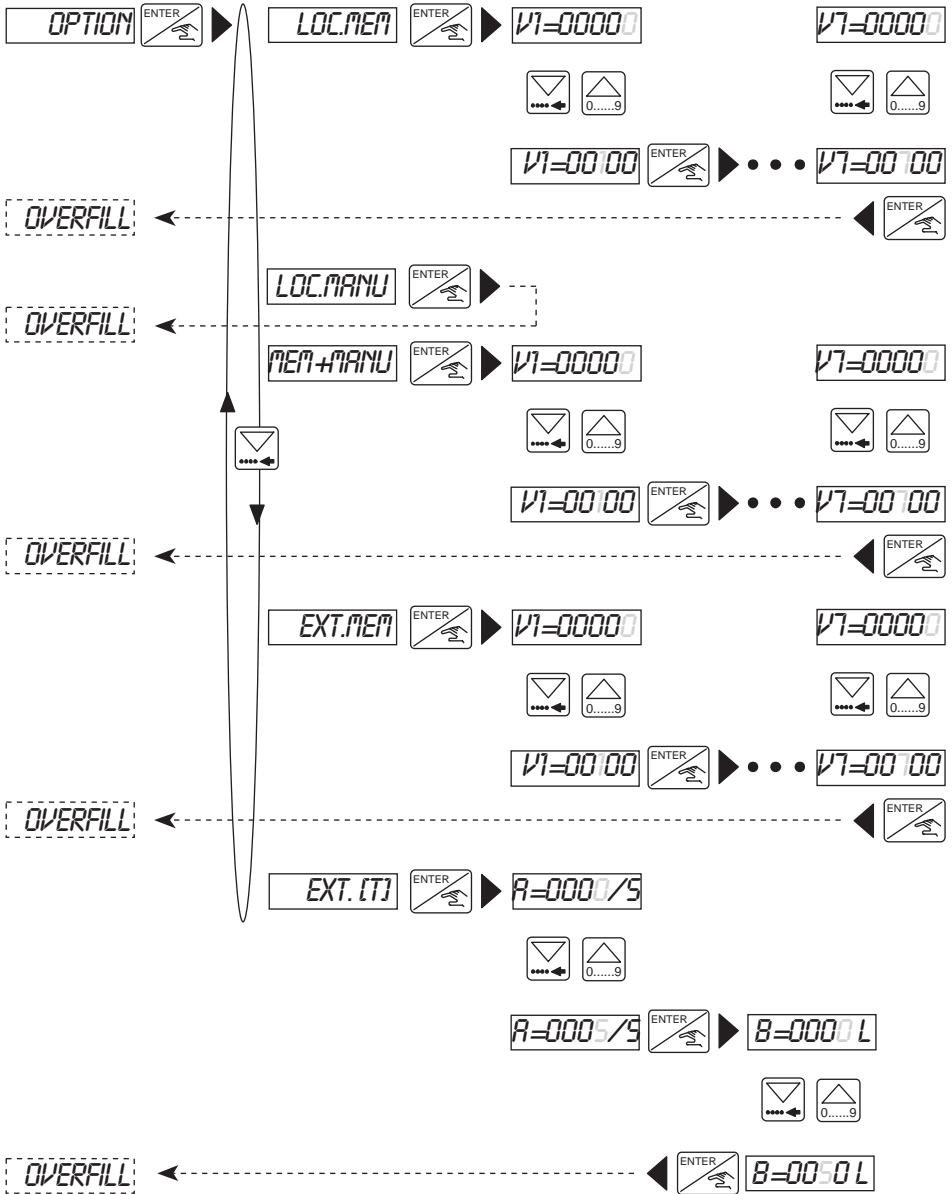
For more information on these options, see § 4.2



When entering volumes (quantities) V1 to V7, the measurement unit which applies is the one selected for the the dosing volume (see Calibration Menu).

Note: A decimal point can be entered by simultaneously pressing keys  . It will always be positioned to the right of the flashing digit.

## 4.4.5. Overfill correction

The 8035 Batch controller has an overfill correction facility. It memorises the fluid volume which flows after the closure of the valve so that this volume can be deducted from the next batch. In this sub-menu the user enables or disables the overfill correction facility.

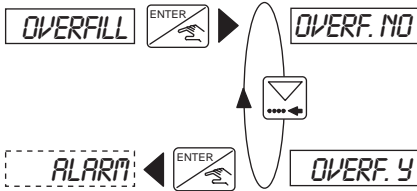

## 4.4.6 Alarm

The menu makes it possible to enable or disable the trigger-off of the alarm during a dosage (DURING option) and/or after a dosage (AFTER option). It also makes it possible to program the time delay before the alarm is triggered off, for either option. The alarm display prompt is «ALARM». This alarm data prompt is also available on tag strip terminal N°. 5 (transistor output, open collector) and on Relay N° 2 if this relay has been configured as an alarm relay (see next paragraph).

For the conditions required to trigger off the alarm, see Section 5.

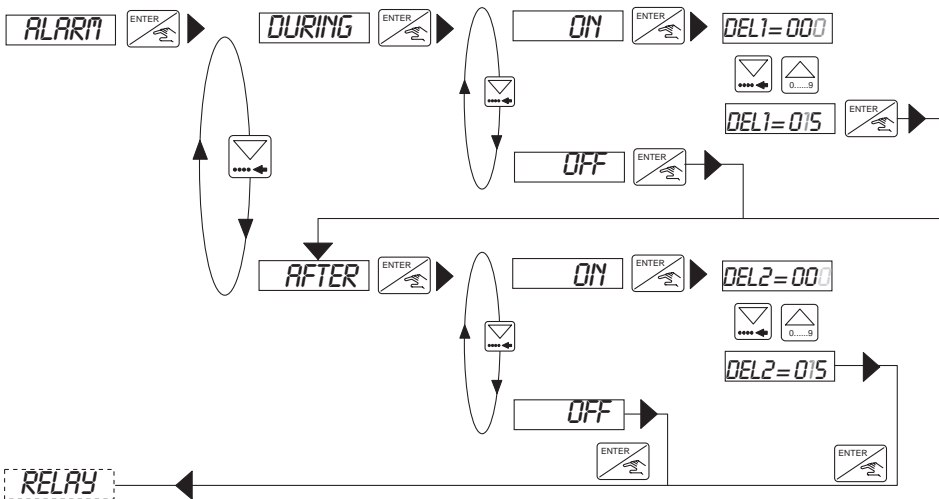

Range of adjustment: between 0 and 999 seconds.

Remark: The time delay before the alarm is triggered off must take into account the overfill correction if enabled.

**4.4.7. Relays**

The 8035 Batch controller provides 2 relays:

- Relay 1 controls the opening of the main valve (high flow rate). A delay before activation may be selected and the operating polarity may be inverted; the user also has the facility of setting the percentage of the selected volume to be delivered through the main valve (high flow rate). This implies that the Relay 2 controls an auxiliary valve (low flow rate) in order to provide the remainder of the entire selected volume.
- Relay 2 can be configured for three different functions: Alarm, End of the dosing and Control of an auxiliary valve. In each configuration the operating polarity can be inverted.

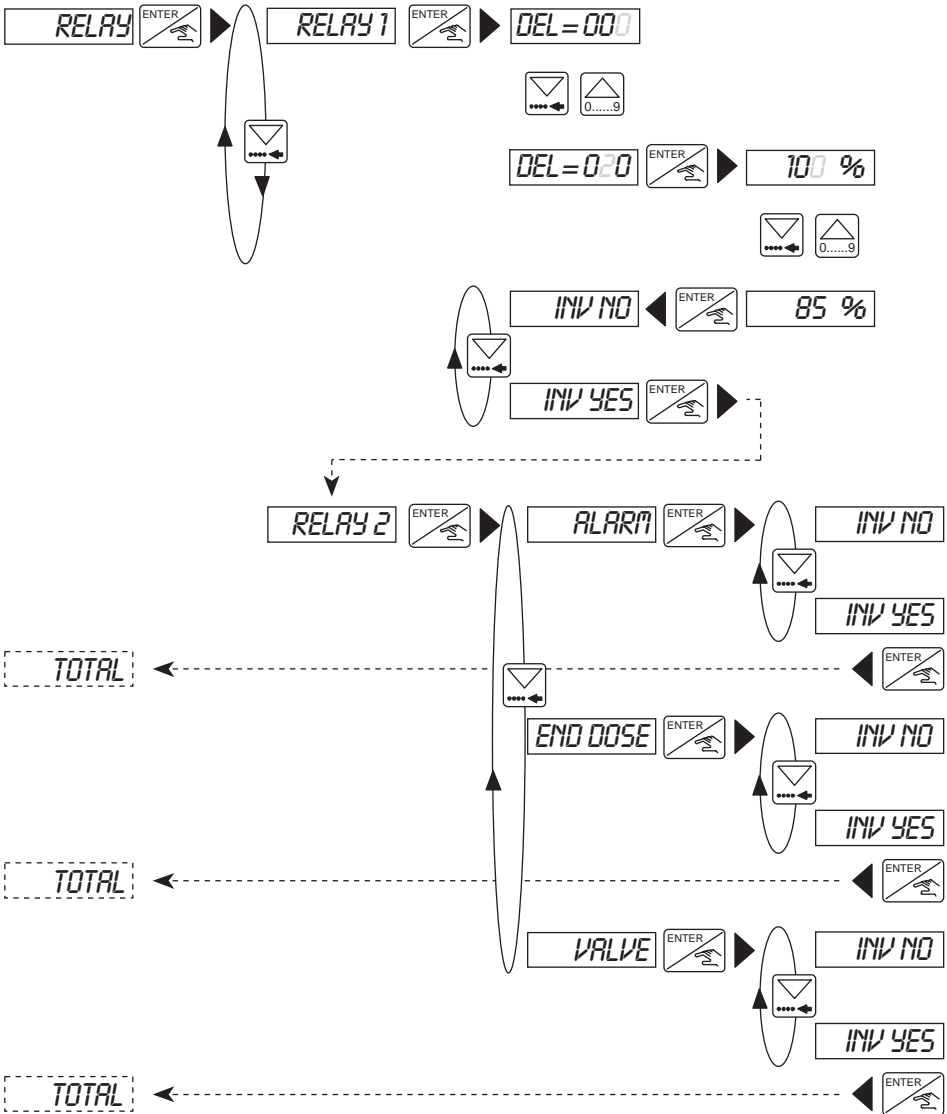

**Notes:**

- If Relay 1 is configured for a percentage flow rate different from 100, then Relay 2 will automatically be configured for valve control. The other options will no longer be available.
- Relay 1 will not open the valve until the entered delay period has elapsed.

## 4.4.8 Totalizer

Simultaneous setting of both counters to zero. This facility becomes operational when the user presses the ENTER key while in the «END» option within the Calibration menu.

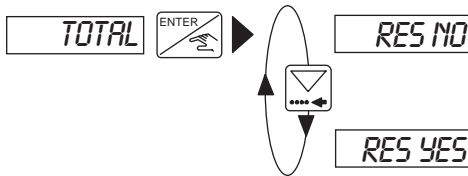

The totalizers are automatically reset when the K factor is modified.



## 4.5 Test Menu: Press simultaneously for 5 s.

The following adjustments and checks are carried out in the Test Menu:

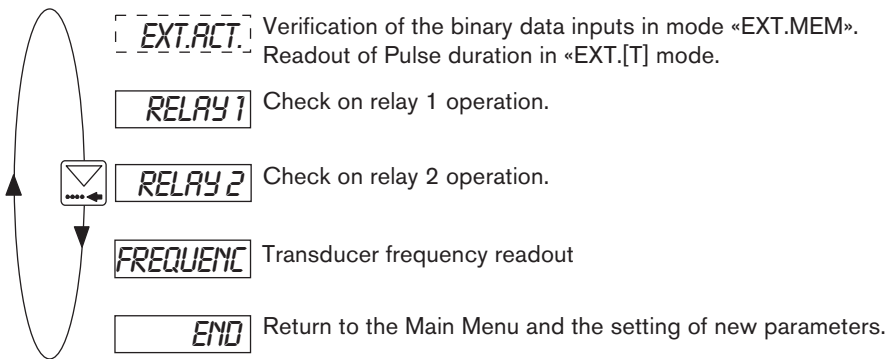

### 4.5.1 EXT.ACT.

This sub-menu provides for checking the allocation of binary logic levels to the binary data inputs under the «EXT.MEM» dosing option and also provides a readout of the pulse duration under option «EXT [T]».

#### «EXT.MEM» Option

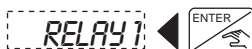

Readout of quantities corresponding to the coding of the binary inputs (by using the rotary knob, for example). If the readout shows «--» the coding of the inputs corresponds to a zero volume.

## «EXT. [T] Option

In this option, the user can check the pulse duration being sent to the 8035 Batch controller.



### 4.5.2. Check on operation of relays

This option allows the operator to check for correct operation of the relays by using the keypad to energise the relays.

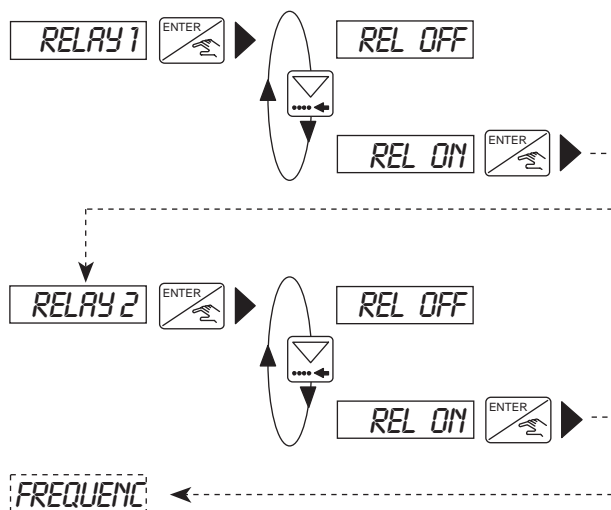

### 4.5.3. Frequency readout

Readout of paddlewheel rotation frequency. To clear the display and proceed to the next option, press the ENTER key.



**Note:** After the display of the «FREQUENC» prompt, pressing the ENTER key will energise Relay 1 (to open the valve).

## 5.1 Fault prompts

### 5.1.1. «ALARM» prompt

#### "ALARM" PROMPT DURING A DOSAGE

The «ALARM « prompt will be displayed during a dosage operation (irrespective of the dosage option) if one or both valves are open but the controller does not detect any flow. The time delay before triggering the alarm is set in the Calibration menu. (see § 4.4.6).

A dosage that has been stopped by the alarm can either be continued or cancelled:

#### a) Manual or automatic dosage activated by LOC.MANU, LOC.MEM or MEM+MANU:

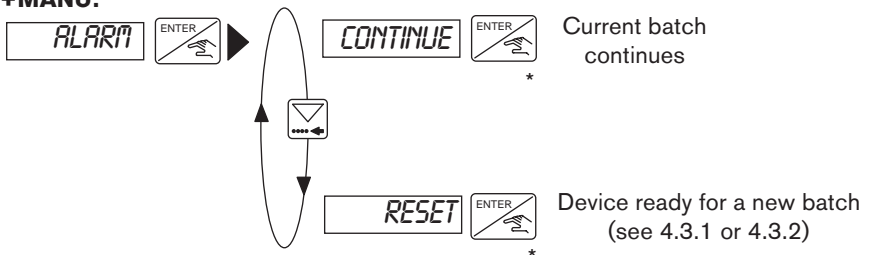

\* When in mode MEM+MANU, LOC.MEM or LOC.MANU, you can also start the dosage using the 'Start/Pause' Binary Data Input.

#### b) Dosage through Binary Inputs and activated by EXT.MEM :

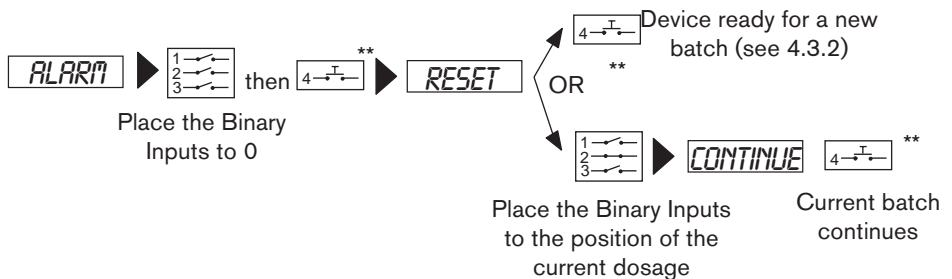

(\*\*) When in mode EXT.MEM or EXT [T], you can also press the Enter key on the keypad.

## c) Dosage through Binary Inputs and activated by EXT.MEM :

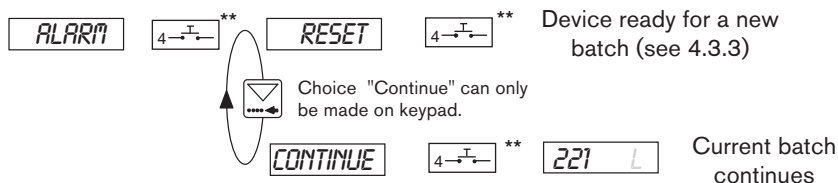

(\*\*) When in mode EXT.MEM or EXT [T], you can also press the Enter key on the keypad.

## "ALARM" PROMPT AT THE END OF A DOSAGE

The «ALARM» prompt will be displayed at the end of a dosage operation (irrespective of the dosage option) if one or both valves are closed and if the controller detects that there is still a flow condition after the time delay period before alarm triggering has elapsed.

Note: The alarm time delay must take account of any jet correction that may have been entered (the fluid quantity which continues to flow after the closure of the valve).

## a) Manual or automatic dosage activated by LOC.MANU, LOC.MEM or MEM+MANU:



## b) Dosage through Binary Inputs and activated by EXT.MEM or EXT [T]:



(\*\*) When in mode EXT.MEM or EXT [T], you can also press the Enter key on the keypad.

## 5.1.2.«[T] ERROR» prompt

This error prompt only occurs in the «EXT.[T]» option. It is displayed during a dosing operation if the duration of the pulse is greater than 300 seconds, or if it is greater than the duration necessary to deliver the relevant volume.

It will also appear if the volume to deliver is greater than 100000 (l, m<sup>3</sup>, etc.) or if the volume delivered has reached 100000 (l, m<sup>3</sup>, etc.) and when the pulse has not been switched off.



Device ready for a new batch  
(see 4.3.3)

\*\*

(\*\*) When in mode EXT.MEM or EXT [T], you can also press the Enter key on the keypad.

## 5.1.3. «ERROR» prompts

ERROR 1 displayed at the starting up of the transmitter indicates a read error of the totalizers: cut off the power of the device then power the transmitter again. If ERROR 1 is still displayed, press ENTER: the values of the totalizers are displayed. These values are probably false: enter the CALIB menu to reset the totalizers and come back to the normal operating of the transmitter.

ERROR 2 displayed at the starting up of the transmitter indicates a read error of the calibration parameters (unit, K factor,...): cut off the power of the device then power the transmitter again. If ERROR 2 is still displayed, press ENTER to load the default values and program the transmitter again through the CALIB menu. The totalizers are not reset.

ERROR 3 displayed at the starting up of the transmitter indicates a read error of the totalizers and the calibration parameters (unit, K factor,...): cut off the power of the device then power the transmitter again. If ERROR 3 is still displayed, press ENTER to reset the totalizers if necessary and program the transmitter again through the CALIB menu.

## 5.2. Transducer maintenance

In correct installation conditions, the 8035 Batch controller is maintenance free. If clogging occurs, the immersed parts of the sensor can be cleaned with water or any other cleaning agent suitable for use with PVDF.

## 5.3 Factory and user settings

Language:	English	Overfill correction:	yes
Unit flow:	L/s	Alarm DURING: On,	DEL1 = 100
Unit totalizers:	L	Alarm AFTER: On,	DEL2 = 100
Decimal point:	0	Relay 1:	DEL = 000
Unit batch:	L		100 %
K-Factor:	001.00		inversion: NO
Batch option:	MEM+MANU	Relay 2:	VALVE
Quantities V1 to V7:	00000		inversion: NO

## User settings

Language:	Overfill correction:	
Unit flow:	Alarm DURING:	DEL1 =
Unit totalizers:	Alarm AFTER:	DEL2 =
Decimal point:		
Unit batch:	Relay 1:	inversion:
K-Factor:		
Batch option:	Relay 2:	inversion:
Quantities V1 to V7:		

## 5.4. Spare Parts List

Position	Specification	Order N°.
1	Complete housing	430833
2	Power supply board, 115/230 VAC	448393
3+5+6+7	Set incl. 2 cable glands M20x1,5 + 2 neoprene flat gaskets for cable gland or screwed plug + 2 screwed plugs M20x1,5 + 2 multiway seals 2x6 mm	449755
4+5+6+7	Set incl. 2 reductions M20x1,5 / NPT1/2" (mounted gasket) + 2 neoprene flat gaskets for screwed plug + 2 screwed plugs M20x1,5	551782
	Instruction manual Inline Fitting S030	426107

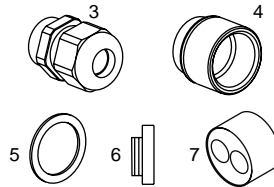
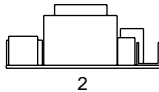
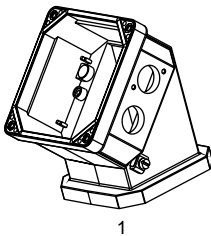

**Flow chart (l/s, l/min, m<sup>3</sup>/h, DN in mm und m/s)**

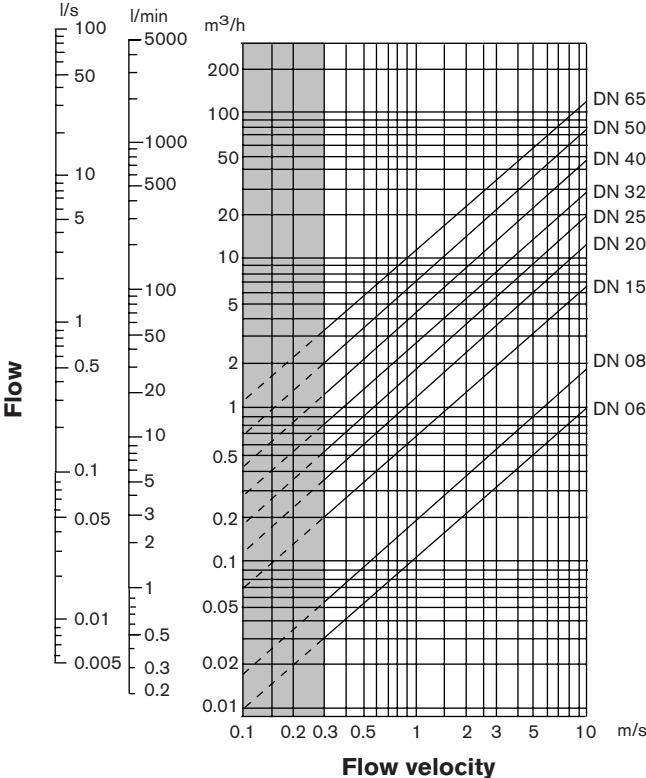

**Example Specifications**

Flow 10 m<sup>3</sup>/h  
Determination with ideal flow velocity: 2...3 m/s

With these specifications, the required orifice as defined by the flow chart is DN 40

**Flow chart (gpm, DN in inch and fps)**

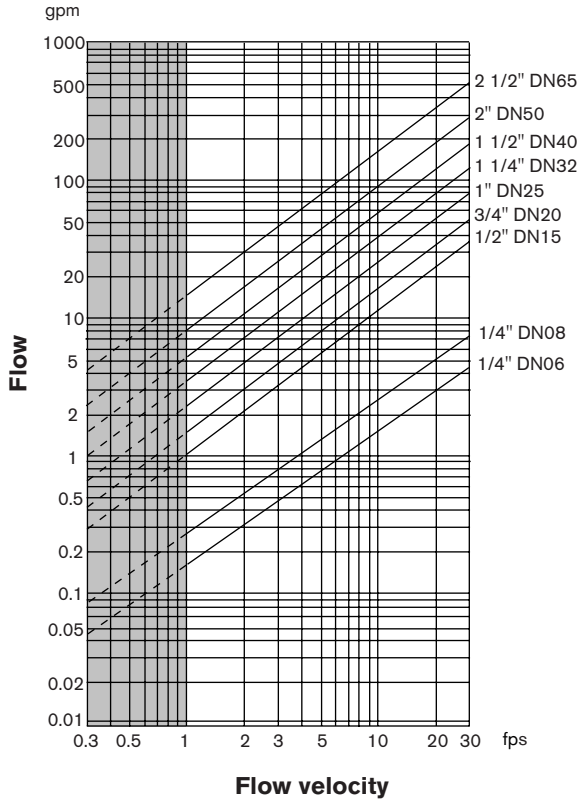

**Example Specifications**

Flow 50 gpm  
 Determination with ideal flow velocity: 8 fps

With these specifications, the required orifice as defined by the flow chart is DN 40



