

2031 Forged

2/2-way Diaphragm Valve, forged valve body, weld end and Tri-Clamp® connection, 1/4"-4"



Type 2031
with weld end
connection

Type 2031
with Tri-Clamp®
connection

Type 2031 Forged can be combined with...



Accessory 1062

Electrical position
feedback

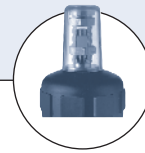

Accessory

Stroke limitation

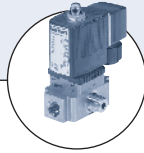

Type 6012/6014P

Pilot valve

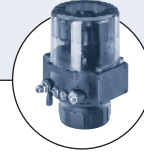

Type 8631

TopControl
ON/OFF
Pilot/Switch package

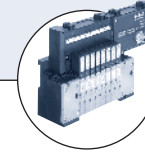

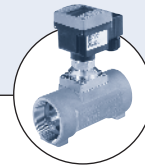

Type 8640/8644

Valve bank



Type 8311

Pressure Sensor/
Switch

- Hermetical separation of fluids from the operating mechanism by diaphragm
- Zero dead volume
- Various surface finishes
- Quality certifications  / 
- USP Class VI diaphragms
- Higher temperature diaphragms available

The externally piloted diaphragm valve consists of a pneumatically operated piston actuator, a diaphragm and a 2-way valve housing made of forged stainless steel.

The standard material of the actuator is PPS. With its favourable flow characteristics and zero dead volume, the valve housing enables high flow capacities and a variety of applications to be realized.

Technical data	
Body materials	Forged stainless steel 316 L/1.4435 / BN2 Fe < 0.5% / C ≤ 0.03%
Actuator size 40–125mm	PPS (polyphenyl sulfide)
Actuator size ≥ 175mm	PA (polyamide)
Pilot air ports	Stainless steel 1.4305
Seal material	EPDM, PTFE/EPDM (FKM on request)
Media	Neutral gases and liquids, high-purity, sterile, aggressive or abrasive fluids
Viscosity	No limit
Surface finish (Average surface finish)	
internal mechanical polished	Ra ≤ 0.5 µm 20 µin
internal electro polished	Ra ≤ 0.4 µm 15 µin
internal mirror finished (other see ordering chart)	Ra ≤ 0.25 µm 10 µin
Media temperature	
EPDM	14°F to 266°F (-10°C to 130°C)
PTFE/EPDM	14°F to 266°F (-10°C to 130°C)
Ambient temperature	
Actuator size < 100	41°F to 284°F (5°C to 140°C)
Actuator size 100-125	41°F to 194°F (5°C to 90°C) / Briefly up to 284°F (140°C)
Actuator size ≥ 175	14°F to 122°F (-10°C to 50°C)
Control media	Neutral gases; air
Pilot pressure max.	Max. 100 PSI, see table on p. 2
Port connections	
Weld end acc. to	ASME BPE
Tri-Clamp® acc. to	ASME BPE
Installation	On drain angle

Applications

- Pharma
- Biotechnology
- Food and beverage industry

Technical data

Orifice		Cv-value	Actuator size Ø [mm]	Pilot pressure (PSI)		Max. operating pressure for seal material [PSI]		Weight [lb]
[mm]	[inch]			min.	max.	EPDM	PTFE/EPDM	
8	1/4"	1.16	C-40	72.5	101.5	150	150	0.8
10	3/8"	1.16	C-40	72.5	101.5	150	150	0.8
15	1/2"	4.6	D-50	72.5	101.5	123	72.5	1.5
		5.2	E-63	72.5	101.5	150	150	1.9
20	3/4"	8.1	E-63	80.0	101.5	150	72.5	2.9
		8.7	F-80	72.5	101.5	150	150	4.4
25	1"	13.9	E-63	72.5	101.5	43.5	-	3.5
			F-80	80.0	101.5	150	108	4.9
40	1 1/2"	34.8	G-100	80.0	101.5	94	87	9.3
		35.4	H-125	80.0	101.5	150	150	12.6
50	2"	59.7	G-100	80.0	101.5	65	36	13
			H-125	80.0	101.5	116	101.5	16.8
80	3"	185	K-175	72.5	87.0	72.5	65	42.0
			L-225	72.5	87.0	150	150	58.0
100	4"	272	L-225	72.5	87.0	116	58	84.0

Remark:

For low operating pressures we recommend reduced spring versions.

Installation for self-draining operation

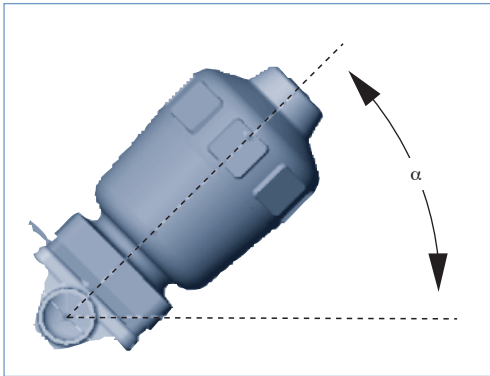

$\alpha = 15$ up to 35° pipe slope per pipe requirement.

For detailed installation angle values, please contact your local Burkert representative

Ordering chart for valves (other versions on request)

Body with weld end

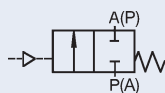

Control function A
2/2-way, NC by
spring return

Orifice		external-Ø [inch]	Cv-value	Actuator size Ø [mm]	Pilot pressure [PSI]	Max. op. pressure [PSI]	Internal/external:		Item no.			
[mm]	[inch]						standard Mechanical polished, Ra ≤ 20/250 µm	Electro polished, Ra ≤ 15/125 µm	Mechanical polished, Ra ≤ 20/63 µm	Electro polished, Ra ≤ 15/32 µm	Mirror finished, Ra ≤ 10/10 µm	
Acc. ASME BPE, diaphragm material EPDM												
8	1/4"	1/4"	1.2	C-40	72-101	150	448 273	447 896	447 897	447 898	447 899	
10	3/8"	3/8"	1.2	C-40	72-101	150	447 900	447 901	447 902	447 903	447 904	
15	1/2"	1/2"	4.6	D-50	72-101	123	445 047	445 048	445 049	445 050	445 051	
20	3/4"	3/4"	8.1	E-63	80-101	150	445 052	445 053	445 054	445 055	445 056	
25	1"	1"	13.9	F-80	80-101	150	445 057	445 058	445 059	445 060	445 061	
40	1 1/2"	1 1/2"	34.8	G-100	80-101	65	445 062	445 063	445 064	445 065	445 066	
50	2"	2"	59.7	H-125	80-101	116	445 067	445 068	445 069	445 070	445 071	
65	2 1/2"	2 1/2"	59.7	H-125	80-101	116	550 734	551 381	449 807	551 362	551 366	
80	3"	3"	185.6	L-225	72-87	150	551 409	551 410	551 411	551 412	551 413	
100	4"	4"	272.6	L-225	72-87	116	-	-	449 809	551 386	550 279	
Acc. ASME BPE, diaphragm material PTFE/EPDM												
8	1/4"	1/4"	1.2	C-40	72-101	150	447 915	447 916	447 917	447 918	447 919	
10	3/8"	3/8"	1.2	C-40	72-101	150	447 920	447 921	447 922	447 923	447 924	
15	1/2"	1/2"	4.6	E-63	72-101	150	445 082	445 083	445 084	445 085	445 086	
20	3/4"	3/4"	8.1	F-80	80-101	150	445 087	445 088	445 089	445 090	445 091	
25	1"	1"	13.9	F-80	80-101	108	445 092	445 093	445 094	445 095	445 096	
40	1 1/2"	1 1/2"	34.8	H-125	80-101	150	445 097	445 098	445 099	445 100	445 100	
50	2"	2"	59.7	H-125	80-101	101.5	445 102	445 103	445 104	445 105	445 106	
65	2 1/2"	2 1/2"	59.7	H-125	80-101	101.5	449 521	551 332	551 469	551 470	551 471	
80	3"	3"	185.6	L-225	72-87	150	449 522	551 440	551 441	551 442	551 443	
100	4"	4"	272.6	L-225	72-87	58	-	-	449 523	551 395	551 396	

Remark:

Versions with reduced spring force on request.

Ordering chart for valves (other versions on request)

Body with Tri-Clamp® connection

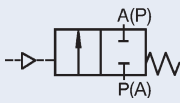

Control function A
2/2-way, NC by
spring return

Orifice		external-Ø [inch]	Cv-value	Actuator size Ø [mm]	Pilot pressure [PSI]	Max. op. pressure [PSI]	Internal/external:		Item no.			
[mm]	[inch]						standard Mechanical polished, Ra ≤ 20/250 µin	Electro polished, Ra ≤ 15/125 µin	Mechanical polished, Ra ≤ 20/63 µin	Electro polished, Ra ≤ 15/32 µin	Mirror finished, Ra ≤ 10/10 µin	
Acc. ASME BPE SHORT CONNECTION, diaphragm material EPDM												
8	1/4"	1/4"	1.2	C-40	72-101	150	445 266	445 267	445 268	445 269	445 270	
10	3/8"	1/4"	1.2	C-40	72-101	150	445 271	445 272	445 273	445 274	445 275	
15	1/2"	1/4"	4.6	E-63	72-101	150	445 276	445 277	445 278	445 279	445 280	
20	3/4"	1/4"	8.1	F-80	72-101	150	445 281	445 282	445 283	445 284	445 285	
25	1"	1/2"	13.9	F-80	80-101	150	445 286	445 287	445 288	445 289	445 290	
40	1 1/2"	1/2"	34.8	G-100	80-101	94	445 291	445 292	445 293	445 294	445 295	
50	2"	2 1/2"	59.7	H-125	80-101	116	445 296	445 297	445 298	445 299	445 300	
80	3"	3 1/2"	185.6	L-225	72-87	87	551 424	551 425	551 426	551 427	551 428	
Acc. ASME BPE SHORT CONNECTION, diaphragm material PTFE/EPDM												
8	1/4"	1/4"	1.2	C-40	72-101	150	445 301	445 302	445 303	445 304	445 305	
10	3/8"	1/4"	1.2	C-40	72-101	150	445 306	445 307	445 308	445 309	445 310	
15	1/2"	1/4"	4.6	E-63	72-101	150	445 311	445 312	445 313	445 314	445 315	
20	3/4"	1/4"	8.1	F-80	80-101	150	445 316	445 317	445 318	445 319	445 320	
25	1"	1/4"	13.9	F-80	80-101	108	445 321	445 322	445 323	445 324	445 325	
40	1 1/2"	1/4"	34.8	H-125	80-101	150	445 326	445 327	445 328	445 329	445 330	
50	2"	2 1/2"	59.7	H-125	80-101	101	445 331	445 332	445 333	445 334	445 335	
80	3"	3 1/2"	185.6	L-225	72-87	72	551 156	551 157	551 158	551 159	551 160	
Acc. ASME BPE LONG CONNECTION, diaphragm material EPDM												
8	1/4"	1/4"	1.2	C-40	72-101	150	445 197	445 198	445 199	445 200	445 201	
15	1/2"	1/4"	4.6	E-63	72-101	150	445 207	445 208	445 209	445 210	445 211	
20	3/4"	1/4"	8.1	F-80	80-101	150	445 212	445 213	445 214	445 151	445 215	
25	1"	1/2"	13.9	F-80	80-101	150	445 216	445 217	445 218	445 219	445 220	
40	1 1/2"	1/2"	34.8	G-100	80-101	94	445 221	445 222	445 223	445 224	445 225	
50	2"	2 1/2"	59.7	H-125	80-101	116	445 226	445 227	445 228	445 229	445 230	
Acc. ASME BPE LONG CONNECTION, diaphragm material PTFE/EPDM												
8	1/4"	1/4"	1.2	C-40	72-101	150	445 231	445 232	445 233	445 234	445 235	
15	1/2"	1/4"	4.6	E-63	72-101	150	445 241	445 242	445 243	445 244	445 245	
20	3/4"	1/4"	8.1	F-80	80-101	150	445 246	445 247	445 248	445 249	445 250	
25	1"	1/2"	13.9	F-80	80-101	108	445 251	445 252	445 253	445 254	445 255	
40	1 1/2"	1/2"	34.8	H-125	80-101	150	445 256	445 257	445 258	445 259	445 260	
50	2"	2 1/2"	59.7	H-125	80-101	101	445 261	445 262	445 263	445 264	445 265	

Remark:

Versions with reduced spring force on request.

Materials

DTS 1000082418 EN Version: A Status: RL (released | freigegeben | validé) printed: 27.08.2008

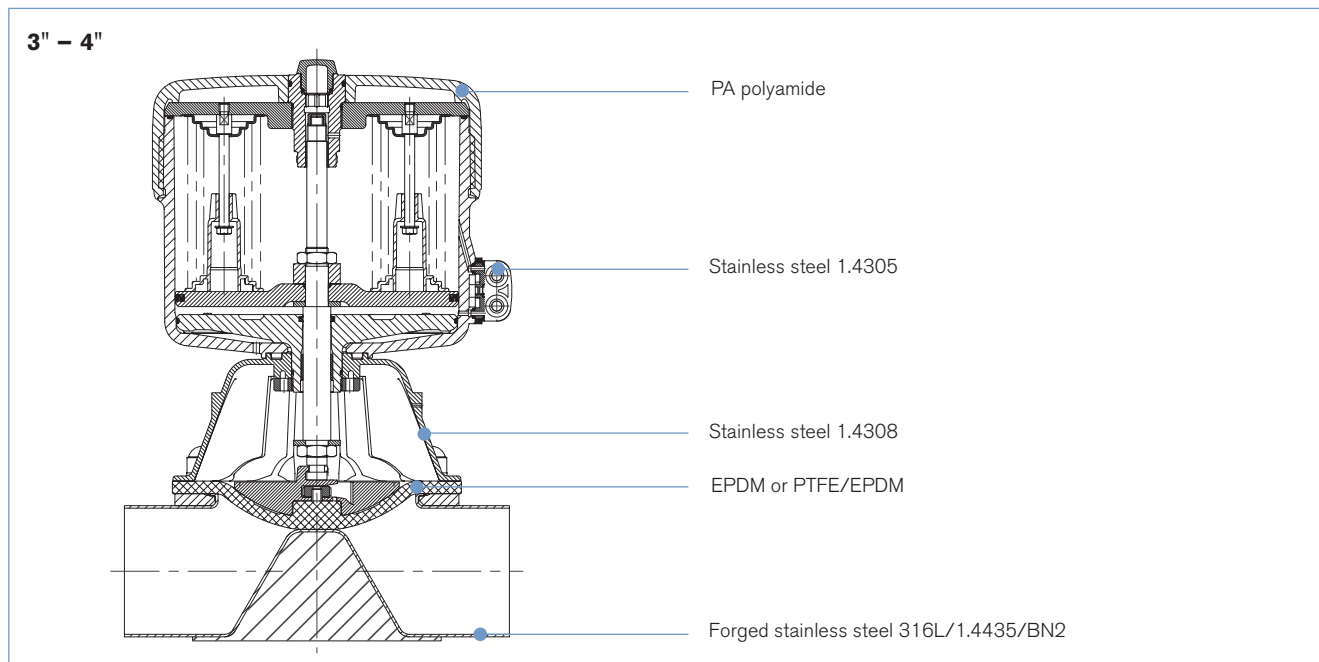
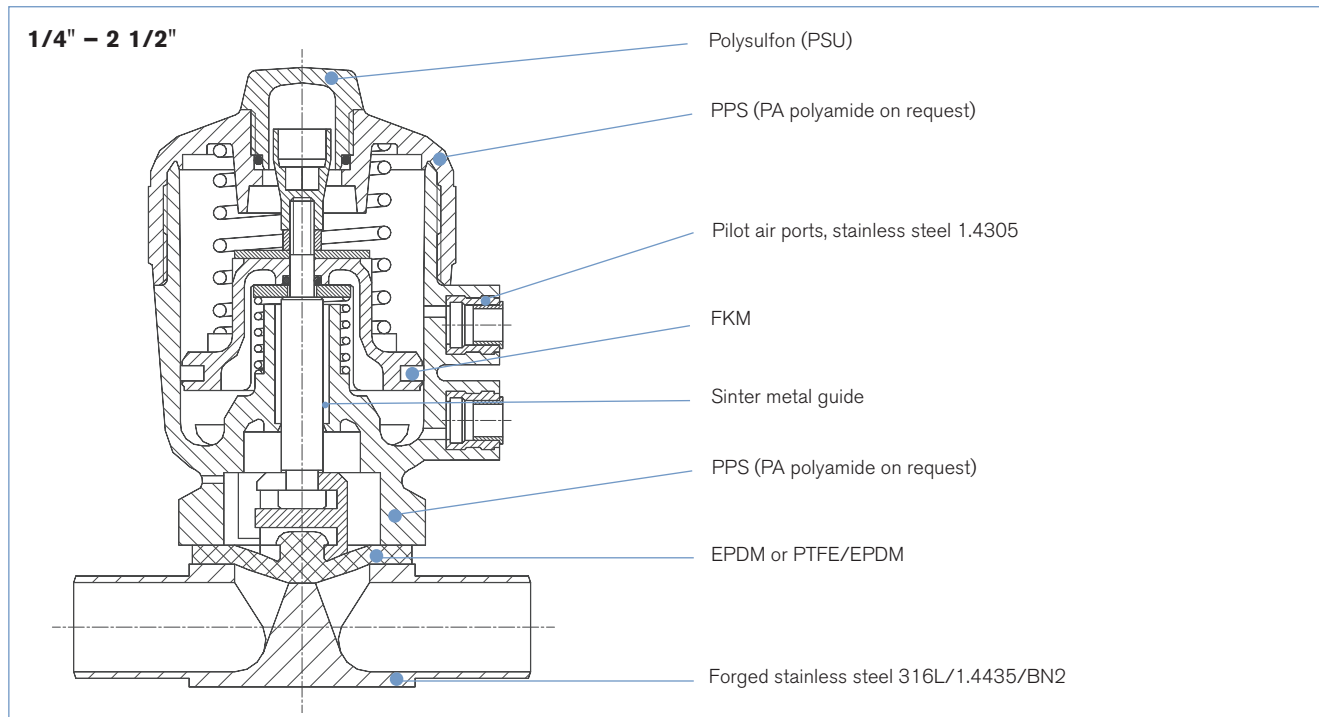

Approvals

Suitable for foodstuffs / sterile applications



- The composition of the EPDM and PTFE/EPDM diaphragms corresponds to the *Code of Federal Regulations*, published by the *FDA* (Food and Drug Administration, USA).
- The EPDM diaphragms correspond to the *KTW-Recommendation* (Plastics in the Drinking Water Sector). A Manufacturer's Declaration will be supplied on request.



- The diaphragm valves are 3-A approved (3-A Sanitary Standards Symbol Administrative Council)

Dimensions [mm]

Body with weld end

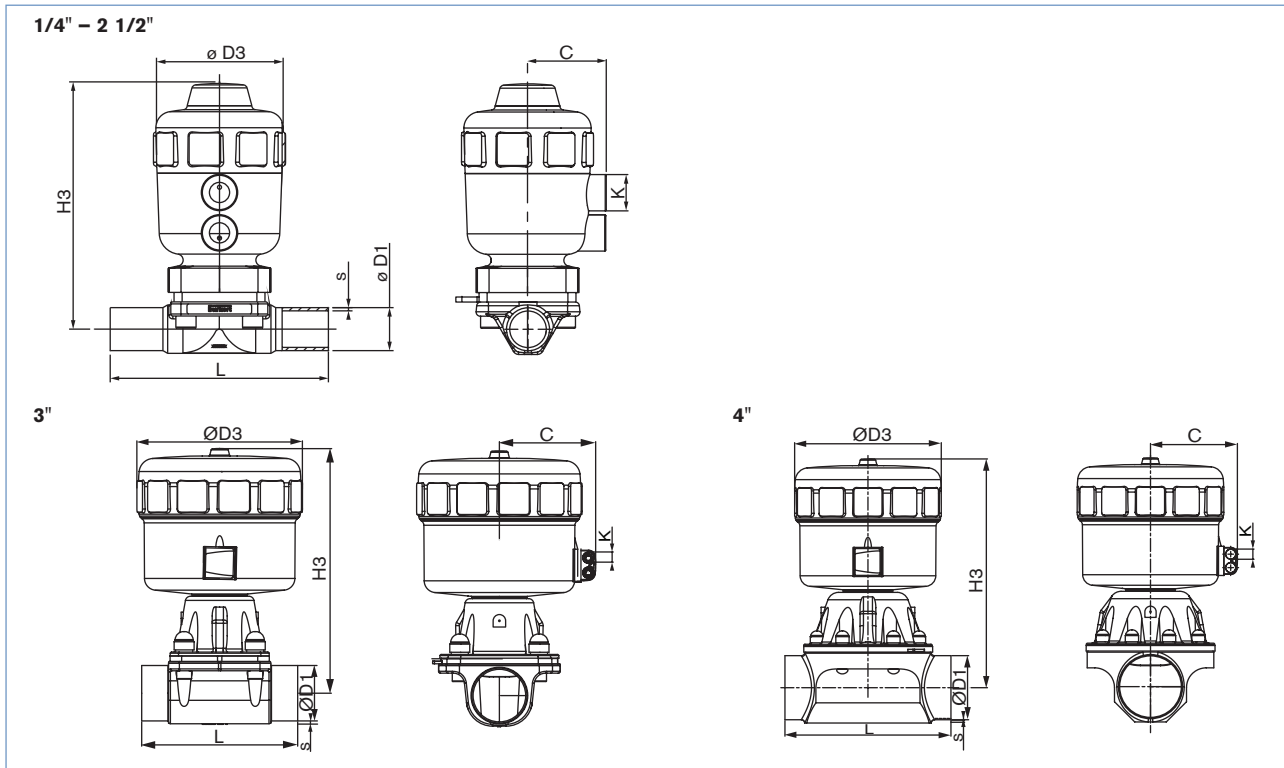

Dimensions acc. BS 4825 and ASME BPE [inch]

Orifice [mm]	[inch]	Actuator size Ø	C	K	L	H3	ØD3	ASME BPE	
								ØD1	s
8	1/4"	C-40	1.3	G 1/8	3.1	3.3	2.1	0.25	0.035
10	3/8"	C-40	1.3	G 1/8	3.5	3.3	2.1	0.37	0.035
15	1/2"	D-50	1.5	G 1/4	4.3	4.8	2.5	0.5	0.065
		E-63	2.0	G 1/4	4.3	5.4	3.1	0.5	0.065
20	3/4"	E-63	2.0	G 1/4	4.6	5.8	3.1	0.75	0.065
		F-80	2.4	G 1/4	4.6	6.9	4.0	0.75	0.065
25	1"	E-63	2.0	G 1/4	5.0	6.2	3.1	1.0	0.065
		F-80	2.4	G 1/4	5.0	7.0	4.0	1.0	0.065
40	1 1/2"	G-100	2.9	G 1/4	6.3	9.2	5.0	1.5	0.065
		H-125	3.4	G 1/4	6.3	10.7	6.0	1.5	0.065
50	2"	G-100	2.9	G 1/4	7.5	9.6	5.0	2.0	0.065
		H-125	3.4	G 1/4	7.5	10.9	6.0	2.0	0.065
65	2 1/2"	H-125	3.4	G 1/4	7.5	10.9	6.0	2.5	0.065
80	3"	L-225	6.1	G 1/4	9.8	15.5	10.3	3.0	0.065
100	4"	L-225	6.1	G 1/4	11.6	16.1	10.3	4.0	0.083

DTS 1000082418 EN Version: A Status: RL (released | freigegeben | validé) printed: 27.08.2008

Dimensions [mm]

Body with Tri-Clamp® connection

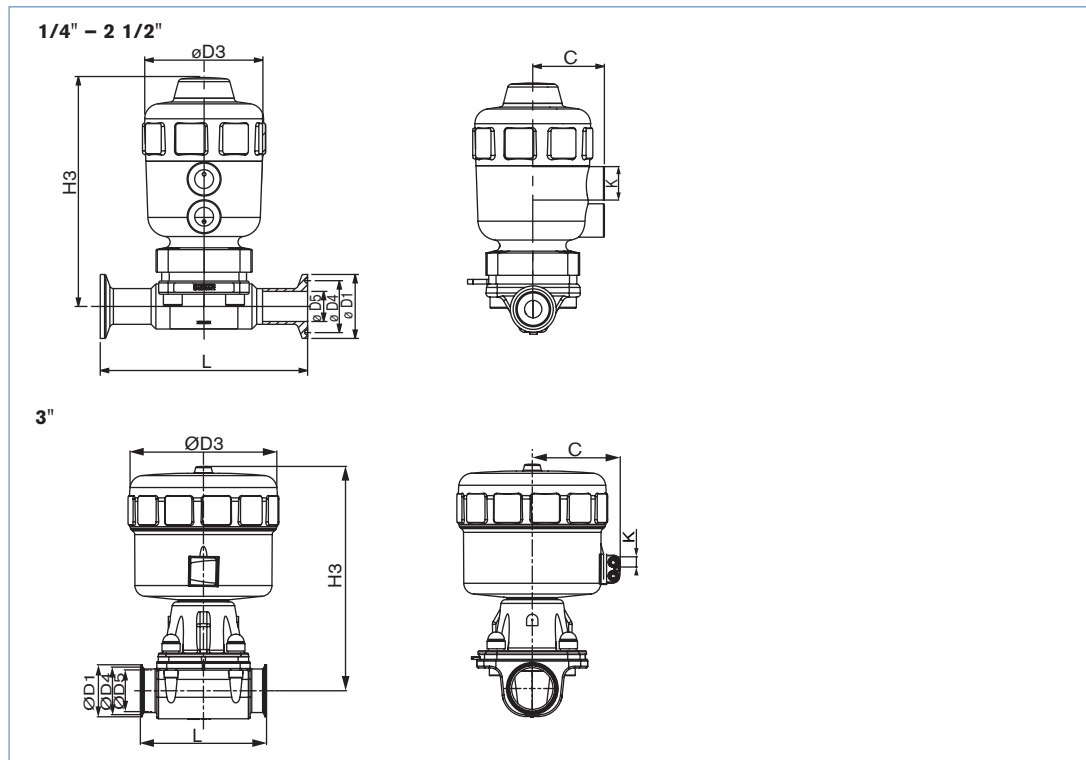

Dimensions acc. ASME BPE long connection and short connection [inch]

Orifice [mm]	Orifice [inch]	Actuator size Ø	C	K	Long conn. L	Short conn. L	H3	ØD3	ØD1	ØD4	ØD5
8	1/4"	C-40	1.3	G 1/8	3.1	2.5	3.3	2.1	1.0	0.8	0.2
10	3/8"	C-40	1.3	G 1/8	3.5	3.5	3.3	2.1	1.0	0.8	0.3
15	1/2"	D-50	1.5	G 1/4	4.2	3.5	4.8	2.5	1.0	0.8	0.4
		E-63	2.0	G 1/4	4.2	3.5	5.4	3.1	1.0	0.8	0.4
20	3/4"	E-63	2.0	G 1/4	4.6	4.0	5.8	3.1	1.0	0.8	0.6
		F-80	2.4	G 1/4	4.6	4.0	6.9	4.0	1.0	0.8	0.6
25	1"	E-63	2.0	G 1/4	5.0	4.5	6.2	3.1	2.0	1.7	0.9
		F-80	2.4	G 1/4	5.0	4.5	7.0	4.0	2.0	1.7	0.9
40	1 1/2"	G-100	2.9	G 1/4	6.2	5.5	9.2	5.0	2.0	1.7	1.4
		H-125	3.4	G 1/4	6.2	5.5	10.7	6.0	2.0	1.7	1.4
50	2"	G-100	2.9	G 1/4	7.5	6.2	9.6	5.0	2.5	2.2	1.9
		H-125	3.4	G 1/4	7.5	6.2	10.9	6.0	2.5	2.2	1.9
65	2 1/2"	H-125	3.4	G 1/4	-	7.5	10.9	6.0	3.0	2.8	2.4
80	3"	L-225	6.1	G 1/4	-	8.7	15.5	10.3	3.6	3.3	2.9

DTS 1000082418 EN Version: A Status: RL (released | freigegeben | validé) printed: 27.08.2008

