

## 2/2-way Miniature Solenoid Valve

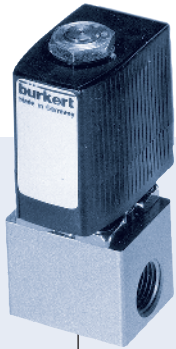

Type 6011 can be combined with...

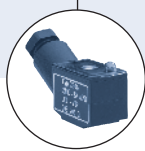

### Type 2506

Cable plug to  
DIN EN 175301-803\*  
form C

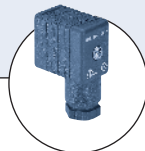

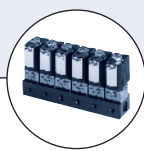

### Type 2507

Cable plug industrial  
standard form B



### Type 6012

Multiple manifold  
(e.g. 6-fold)

- Direct-acting
- 0 to 304 PSI <sup>1)</sup>
- DN 1.2 to 2.4 mm
- UNF 10 – 32, NPT 1/8 and sub-base
- Approvals:   

This direct-acting 2/2-way miniature solenoid valve is available in two versions.

### Standard version:

Type 6011 is a miniature solenoid valve used for shut-off, dosing, filling, ventilating and for technical vacuum. It is of modular design and may be mounted individually or as a block on a multiple manifold.

### Analysis and vacuum technology:

Type 6011 A is a high-quality miniature solenoid valve for analysis and vacuum technology. It is manufactured under clean-room conditions. This includes thorough cleaning of all parts in contact with media from organic and inorganic substances. The limit for residual hydrocarbons is below 0.2 mg/dm<sup>2</sup>. 100 % of the valves are subjected to a special leakage test with regard to tight seating and tightness to the exterior. The permissible leakage rate is 10<sup>-4</sup> mbar l/s. The valve is used for shut-off, dosing, filling, ventilating and particularly for analysis technology.

### Circuit function A

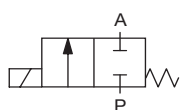

2/2-way valve,  
normally closed by  
spring force

Technical data	
<b>Body material</b>	
Type 6011	brass, polyamide (PA)
Type 6011 A	brass, stainless steel 1.4305
<b>Sealing material</b>	FKM
<b>Analytical version</b> (Type 6011 A)	version free from silicones, oil and grease leaktightness better than 10 <sup>-4</sup> mbar l/s
<b>Limit value for remainder carbon</b> (Type 6011 A)	<0,2 mg/dm <sup>2</sup>
<b>Medium</b>	<ul style="list-style-type: none"> <li>▪ technical vacuum</li> <li>▪ neutral gases and fluids (e.g. compressed air)</li> <li>▪ neutral/aggressive media that do not attack the body and seal materials</li> </ul>
<b>Medium temperature</b>	14°F to 212°F (-10°C to +100°C)
<b>Ambient temperature</b>	max. 131°F (+55°C)
<b>Viscosity</b>	max. 21 cSt
<b>Port connection</b>	
Type 6011	UNF 10 – 32, NPT 1/8, sub-base
Type 6011 A	G1/8, sub-base
<b>Operating voltage</b>	
Type 6011	24 V DC, 24 V/60 Hz, 120 / 240 V / 60 Hz
Type 6011 A	24 V DC, 230 V / 50 Hz
<b>Voltage tolerance</b>	± 10%
<b>Duty cycle/single valve when mounted as a block on a manifold</b>	100% continuous rating Intermittent operation 60% (30 min) or with 2 W coil (on request)
<b>Electrical connection</b>	<ul style="list-style-type: none"> <li>▪ to DIN EN 175301-803* Form C for cable plug Type 2506 (see Ordering chart for Accessories)</li> <li>▪ Form B (industrial standard) for Type 2507 (see Ordering chart for Accessories)</li> </ul>
<b>Installation</b>	as required, preferably with actuator upright
<b>Installation</b>	no oil, grease or silicones to be used as installation aids
<b>Mass</b>	ca. 125 g
<b>Protection class</b>	IP65 with cable plug

<sup>1)</sup> Pressure data [PSI]: Overpressure with respect to atmospheric pressure

<sup>\*)</sup> previously DIN 43650

Response times

Orifice	C <sub>v</sub> value water [GPM]	Pressure range		Coil Power [bar]	Power consumption		Response times	
		for AC [m <sup>3</sup> /h]	for DC [PSI]		Inrush	Hold	Opening [ms]	Closing [ms]
1.2	0.05	0 – 304	0 – 174	4 W AC oder 4 W DC	9 VA	6 VA	7-10	10-15
1.6	0.07	0 – 174	0 – 87					
2.0	0.13	0 – 116	0 – 65		4 W	4 W	7-12	7-12
2.4	0.15	0 – 87	0 – 43					

<sup>1)</sup> Pressure data [PSI]: Overpressure with respect to atmospheric pressure

- C<sub>v</sub> value [GPM]: Flow rate value for water, measured at 68°F (+20°C) and 1 PSI<sup>1)</sup> pressure differential over a fully opened valve.
- Response times [ms]: measured at valve outlet at 87 PSI<sup>1)</sup> and 68°F (+20°C)  
Opening: pressure build-up 0 ... 90 %, closing: pressure relief 100 ... 10 %

Material

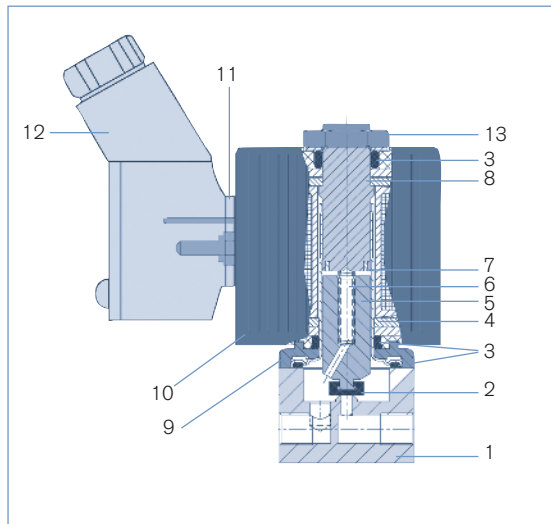

- |                                                                    |                                                                                      |
|--------------------------------------------------------------------|--------------------------------------------------------------------------------------|
| 1 Body                                                             | Brass, stainless steel 1.4305                                                        |
| 2 Armature seal                                                    | PA (polyamide)                                                                       |
| 3 O-ring                                                           | FKM                                                                                  |
| 4 Guide tube                                                       | Stainless steel 1.4303                                                               |
| 5 Core                                                             | Stainless steel 1.4105                                                               |
| 6 Spring                                                           | Stainless steel 1.4310                                                               |
| 7 Shading ring                                                     | Copper, Silver                                                                       |
| 8 Stopper                                                          | Stainless steel 1.4105                                                               |
| 9 Sub-base                                                         | Zn3 gl cC surface (brass version)<br>nickel-plated surface (stainless steel version) |
| 10 Coil<br>DIN EN 175301-803* form C<br>Form B (industr. standard) | PA<br>Epoxy                                                                          |
| 11 Flat seal                                                       | NBR                                                                                  |
| 12 Cable plug                                                      | PA                                                                                   |
| 13 Locknut                                                         | 9SMnPb28K (surface Zn5glcA)                                                          |

<sup>\*)</sup> bisher DIN 43650

Dimensions [mm]

Multiple manifold

No. of valves	A [mm]	B [mm]	C [mm]
1	20	12	-
2	41	33	-
3	62	54	-
4	83	75	-
5	104	96	-
6	125	117	-
7	146	138	-
8	167	159	54

Dimensions [mm]

Single manifold

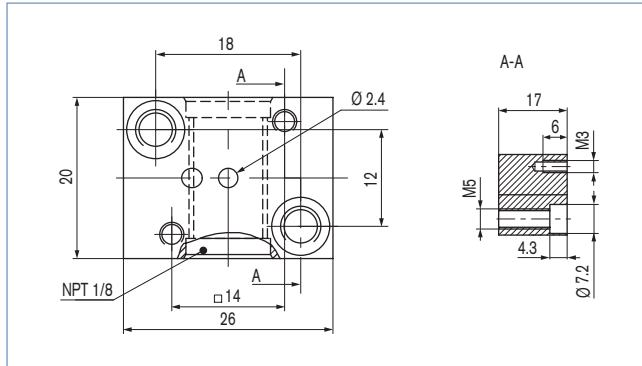

**Type 6011 / 6011 A**  
Version with electrical coil connection  
to DIN EN 175301-803\* form C  
(cable plug type 2506)

**Type 6011 / 6011 A**  
Version with electrical coil connection  
Form B industrial standard  
(cable plug type 2507)

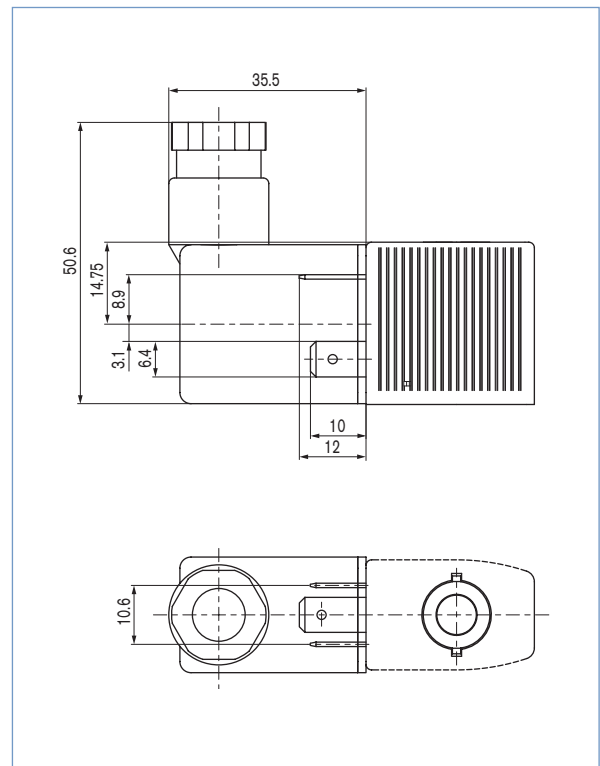
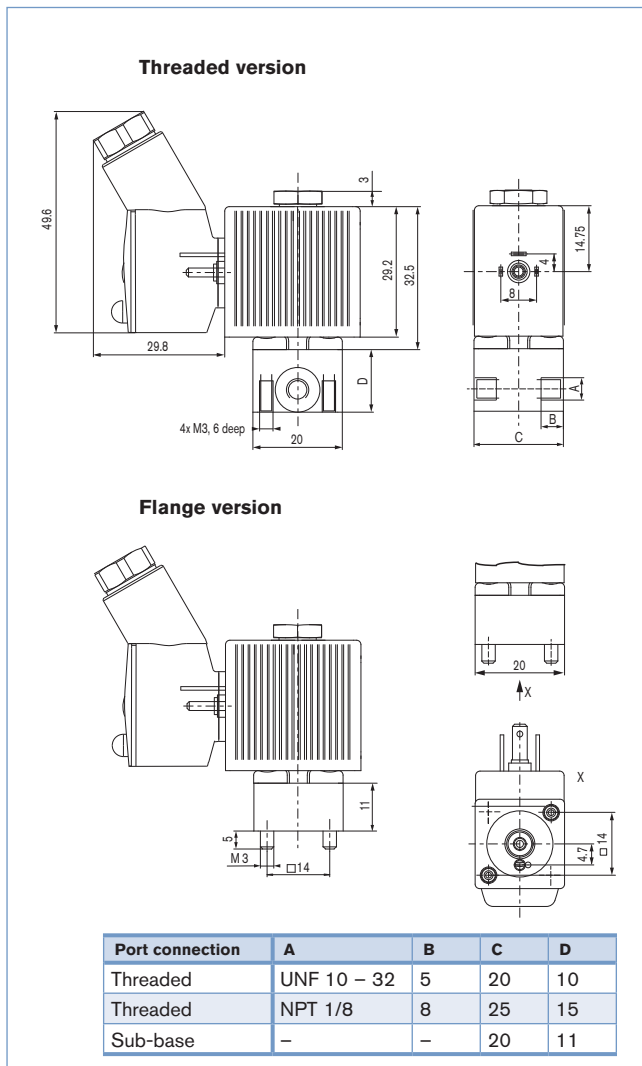

\* previously DIN 43650

## Ordering chart

## Type 6011

Solenoid valve complete in ported or flanged version with electrical coil  
connection to DIN EN 175301-803\* Form C for cable plug Type 2506, cable plug included

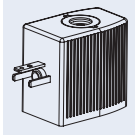

- All valves complete with coil and FKM seal material; without cable plug
- Other versions on request.

Circuit function	Orifice [mm]	Port connection	C <sub>v</sub> value Water [GPM]	Pressure range [PSI] <sup>1)</sup>	Voltage/frequency [V/Hz]	Item no. Brass body	Item no. Stainless steel body
	2.0	UNF 10 – 32	0.12	0 – 65	24/DC	456 776	–
				0 – 116	24/60	456 777	–
				0 – 116	120/60	456 778	–
				0 – 116	240/60	456 779	–
	1.6	NPT 1/8	0.07	0 – 87	24/DC	456 780	457 151
				0 – 174	24/60	456 781	457 152
				0 – 174	120/60	456 782	457 153
				0 – 174	240/60	456 783	457 154
	2.0	NPT 1/8	0.13	0 – 65	24/DC	456 784	457 155
				0 – 116	24/60	456 785	457 156
				0 – 116	120/60	456 786	457 157
				0 – 116	240/60	456 787	457 158
	2.4	NPT 1/8	0.15	0 – 43	24/DC	456 788	457 159
				0 – 87	24/60	456 789	457 160
				0 – 87	120/60	456 790	457 161
				0 – 87	240/60	456 791	457 162
	1.2	sub-base	0.05	0 – 174	24/DC	456 792	–
				0 – 304	24/60	456 793	–
				0 – 304	120/60	456 794	–
				0 – 304	240/60	456 795	–
1.6	sub-base	0.07	0 – 87	24/DC	456 796	–	
			0 – 174	24/60	456 797	–	
			0 – 174	120/60	456 798	–	
			0 – 174	240/60	456 799	–	
2.0	sub-base	0.13	0 – 65	24/DC	456 800	–	
			0 – 116	24/60	456 801	–	
			0 – 116	120/60	456 802	–	
			0 – 116	240/60	456 803	–	
2.4	sub-base	0.15	0 – 43	24/DC	456 804	–	
			0 – 87	24/60	456 805	–	
			0 – 87	120/60	456 806	–	
			0 – 87	240/60	456 807	–	

<sup>1)</sup> Pressure data [PSI]: Overpressure with respect to atmospheric pressure

<sup>\*)</sup> previously DIN 43650

## Ordering chart

## Type 6011 A

Solenoid valve complete in threaded or flanged version with electrical coil connection to DIN EN 175301-803\* Form C for cable plug Type 2506, cable plug included

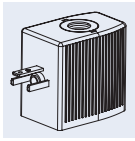

- All valves complete with coil (4 W) and FKM seal material; without cable plug
- Other versions on request.

Circuit function	Orifice [mm]	Port connection <sup>1)</sup>	C <sub>v</sub> value water [GPM]	Pressure range [PSI] <sup>2)</sup>	Voltage/ Frequency [V/Hz]	Item no. Brass body	Item no. Stainless steel body
A 	1.6	G1/8	0.07	0 – 87	24/DC	137 794	137 800
				0 – 174	230/50	137 795	137 801
	2.0	G1/8	0.13	0 – 65.25	24/DC	137 796	137 802
				0 – 116	230/50	137 797	137 803
	2.4	G1/8	0.15	0 – 43.5	24/DC	137 798	137 804
				0 – 87	230/50	137 799	137 805
	1.2	sub-base	0.05	0 – 174	24/DC	137 806	137 812
				0 – 304.5	230/50	137 807	137 813
	1.6	sub-base	0.07	0 – 87	24/DC	137 808	137 814
				0 – 174	230/50	137 809	137 815
	2.0	sub-base	0.13	0 – 65.25	24/DC	137 810	137 816
				0 – 116	230/50	137 811	137 817

<sup>1)</sup> NPT available on request

<sup>2)</sup> Pressure data [PSI]: Overpressure with respect to atmospheric pressure

<sup>3)</sup> previously DIN 43650

## Ordering chart

## Type 6011

Solenoid valve complete in ported or flanged version with electrical coil connection Form B (industrial standard) for cable plug Type 2507, cable plug included

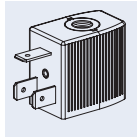

- All valves complete with coil and FKM seal material; without cable plug
- Other versions on request.

Circuit function	Orifice [mm]	Port connection	C <sub>v</sub> value Water [GPM]	Pressure range [PSI] <sup>1)</sup>	Voltage/frequency [V/Hz]	Item no. Brass body	Item no. Stainless steel body
A 	2.0	UNF 10 – 32	0.05	0 – 65	24/DC	461 763	–
				0 – 116	24/60	461 764	–
				0 – 116	120/60	461 765	–
				0 – 116	240/60	461 766	–
	1.6	NPT 1/8	0.07	0 – 87	24/DC	461 767	461 779
				0 – 174	24/60	461 768	461 780
				0 – 174	120/60	461 769	461 781
				0 – 174	240/60	461 770	461 782
	2.0	NPT 1/8	0.13	0 – 65	24/DC	461 771	461 783
				0 – 116	24/60	461 772	461 784
				0 – 116	120/60	461 773	461 785
				0 – 116	240/60	461 774	461 786
	2.4	NPT 1/8	0.15	0 – 43	24/DC	461 775	461 787
				0 – 87	24/60	461 776	461 788
				0 – 87	120/60	461 777	461 789
				0 – 87	240/60	461 778	461 790
	1.2	sub-base	0.05	0 – 174	24/DC	461 791	–
				0 – 304	24/60	461 792	–
				0 – 304	120/60	461 793	–
				0 – 304	240/60	461 794	–
	1.6	sub-base	0.07	0 – 87	24/DC	461 795	–
				0 – 174	24/60	461 796	–
				0 – 174	120/60	461 797	–
				0 – 174	240/60	461 798	–
2.0	sub-base	0.13	0 – 65	24/DC	461 799	–	
			0 – 116	24/60	461 800	–	
			0 – 116	120/60	461 801	–	
			0 – 116	240/60	461 802	–	
2.4	sub-base	0.15	0 – 43	24/DC	461 803	–	
			0 – 87	24/60	461 804	–	
			0 – 87	120/60	461 805	–	
			0 – 87	240/60	461 806	–	

<sup>1)</sup> Pressure data [PSI]: Overpressure with respect to atmospheric pressure

## Ordering chart

## Type 6011 A

Solenoid valve complete in threaded or flanged version with electrical coil connection Form B (industrial standard) for cable plug Type 2507

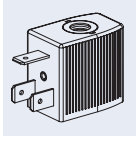

- All valves complete with coil (4 W) and FKM seal material; without cable plug
- Other versions on request.

Circuit function	Orifice [mm]	Port connection <sup>1)</sup>	C <sub>v</sub> value water [GPM]	Pressure range [PSI] <sup>2)</sup>	Voltage/ Frequency [V/Hz]	Item no. Brass body	Item no. Stainless steel body
A 	1.6	G1/8	0.07	0 – 87	24/DC	163 545	163 551
				0 – 174	230/50	163 546	163 552
	2.0	G1/8	0.13	0 – 65.25	24/DC	163 547	163 553
				0 – 116	230/50	163 548	163 554
	2.4	G1/8	0.15	0 – 43.5	24/DC	163 549	163 555
				0 – 87	230/50	163 550	163 556
	1.2	sub-base	0.05	0 – 174	24/DC	163 557	163 563
				0 – 304.5	230/50	163 558	163 564
	1.6	sub-base	0.07	0 – 87	24/DC	163 559	163 565
				0 – 174	230/50	163 560	163 566
	2.0	sub-base	0.13	0 – 65.25	24/DC	163 561	163 567
				0 – 116	230/50	163 562	163 568

<sup>1)</sup> NPT available on request

<sup>2)</sup> Pressure data [PSI]: Overpressure with respect to atmospheric pressure

## Ordering chart for accessories

## Manifolds

Material	No. of valves	Item no.
Aluminium anodized	1	613 984
	2	006 113
	3	613 838
	4	006 114
	5	613 839
	6	613 840
	7	613 841
	8	613 842

## Accessories for manifolds

Accessory	Features	Item no.
Blanking plug	with seal ring, G1/8	005 041
Cover plate	for unused valves	005 100

## Cable plug type 2506 to DIN EN 175301-803\* form C

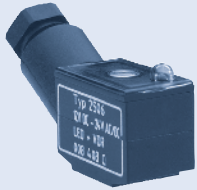
	Circuitry	Voltage	Item no.
	None (standard)	0 - 250 V AC/DC	008 353
	with LED	12 - 24 V AC/DC	008 402
	with LED and varistor	12 - 24 V AC/DC	008 408
	with rectifier, LED and varistor	12 - 24 V AC/DC	008 354

- Supplied with cable plug; flat seal and fixing screw.
- Other versions of cable plug with circuitry to DIN EN 175301-803\* Form C (see Datasheet Type 2506).

<sup>\*)</sup> previously DIN 43650

## Cable plug type 2507 Form B (industrial standard)

	Circuitry	Voltage	Item no.
	None (standard)	2 - 250 V AC/DC	423 845
	with LED	24 V AC/DC	423 849
	with LED and freewheeling diode	12 - 24 V DC	423 851
	with rectifier, LED and varistor	12 - 24 V AC/DC	423 853

- Supplied with cable plug; flat seal and fixing screw.
- Other versions of cable plug with circuitry Form B (industrial standard) (see Datasheet Type 2507).