

# Progressing Cavity Pumps

and Replacement Parts

# Progressing Cavity Pumps

Setting the Standard for Premium Quality Products

**If you're pumping viscous, abrasive, shear sensitive, or solids-containing materials...**

**If your process involves extremely thick and dry materials, or substances that are prone to buildup...**

**Roper Pump can supply a reliable and long-lasting PC Pump tailored to the specific needs of your process.**

Our Progressing Cavity Pumps are found in a broad range of industrial applications: Environmental technology, food processing, chemical manufacturing, pulp and paper, and petroleum production to name a few. Progressing cavity pumps have proven to be the favored choice when difficult conveying problems need to be solved. The particular advantages of Roper Pump progressing cavity pumps include the following:

- Pulsation Free Pumping
- High suction lift capabilities
- Gentle pumping action so that very little shear is imparted to the liquid being pumped
- Ability to handle low or high viscosity products with or without solids
- Application versatility
- Minimal maintenance with wear resistant, hardened and easily replaceable universal joint parts
- Rotors are chrome plated for longer service life on abrasive fluids
- Flows are directly proportional to the speed, for easy pumping control
- Pressure stability over a wide speed range
- Ideal for metering applications.



ISO9001:2000 Certified



The Total Pumping Solution

# Roper Pump Has a Configuration to Fit Your Application

## 70200-70700 SERIES PERFORMANCE RANGE

Capacity	0 - 225 m <sup>3</sup> /hr	0 - 1000 GPM
Pressure	0 - 46 Bar	0 - 675 PSI
Viscosity	1 - 1,000,000 cSt	28 - 4,500,000 SSU
Temperature	205° C	400° F

## The Workhorse of our Progressing Cavity Pump Line

### Model 70200 (Standard Pin Joint)

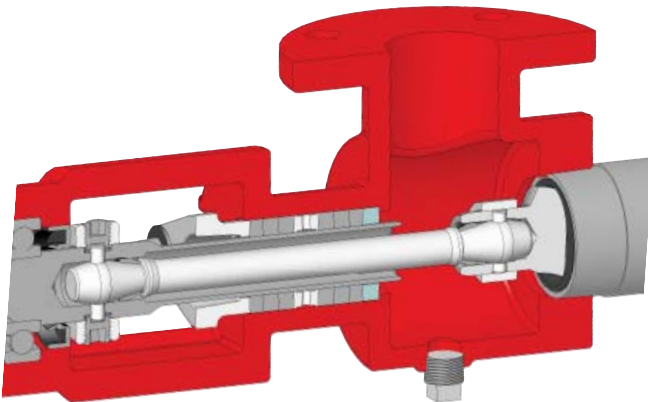

## Our Most Robust Drive Joint

### Model 70400 (Gear Joint)

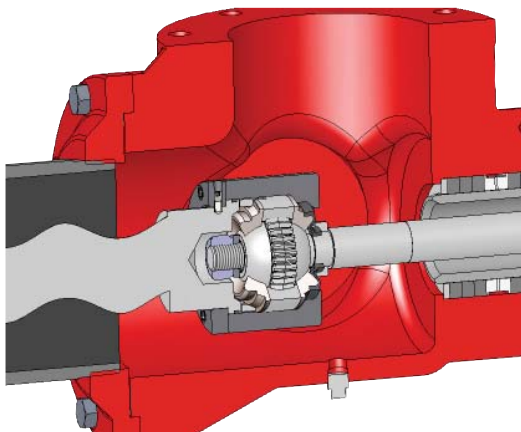

**We offer pump units and packages to meet your specific needs.**

**Our experienced application engineers will help you select the right pump for both the material being handled, and the overall operating conditions.**

The model 70200 is ideal for handling a wide variety of materials which are often considered unpumpable.

The 70200 offer the most economical solution for tough pumping problems like:

- Highly viscous materials
- Abrasive
- Shear-sensitive
- Solids-laden materials.

A hardened steel pin joint drive system, and corrosion-resistant 316 stainless steel pins means durability and ease-of-maintenance. The pin joint design has few wearing parts...so you get long, trouble-free performance. And when service is necessary, you can count on simple, low-cost repairs.

Pin Joint Pumps are available in a full range of sizes in 1, 2, 3, 4 and 6-stage pumps to suit a wide variety of applications.

For the most demanding jobs, our 70400 series pump features a crowned gear joint, sealed from the pumpage, and providing a drive system with greater wear area and lower stresses.

Its construction makes this gear joint pump ideal for applications...

- Where a longer maintenance interval is desired
- When accessibility to the pump is limited
- Where downtime must be kept to a minimum

Because the 70400 series gear joint pump comes standard with large clean-out ports, large objects can be removed from the suction housing without dismantling the pump.

The joint features a long-lasting rubber diaphragm seal that flexes with the joint. Since the seal does not rub against any other parts, there is minimal wear. This results in a longer lasting seal, and a longer lasting joint than a pin joint.

# A Full Range of Material Choices and Sealing Options

Roper Pump Company offers multiple configurations of Progressing Cavity Pumps, available in cast iron and stainless steel construction.

Rotors, stators, drive shafts and drive end assemblies can be modified to suit your conditions for almost any application. Rotors are available in hard chrome-plated hardened alloy steel for maximum abrasion resistance, or hard chrome-plated 316 stainless steel, for corrosion and abrasion resistance.

## Elastomer Selection

Stators are available in NBR, Fluoroelastomer, EPDM, HP Rubber, and Natural Rubber. Our HP Rubber resists chunking, and handles temperatures up to 400° F.

## Shaft Sealing Arrangements

Roper Pump offers a variety of shaft sealing options. Graphite impregnated packing is standard. Teflon impregnated packing is optional. Other available arrangements include double and single mechanical seals in both general-purpose and hard-faced construction. You also have a choice of inside or outside mounting. For abrasive or corrosive fluids, mechanical seals can be specified in a variety of material combinations.

## Baseplates and Drives

You can specify Roper progressing cavity pumps factory mounted on structural steel baseplates, complete with V-belts, gear motors and drives.

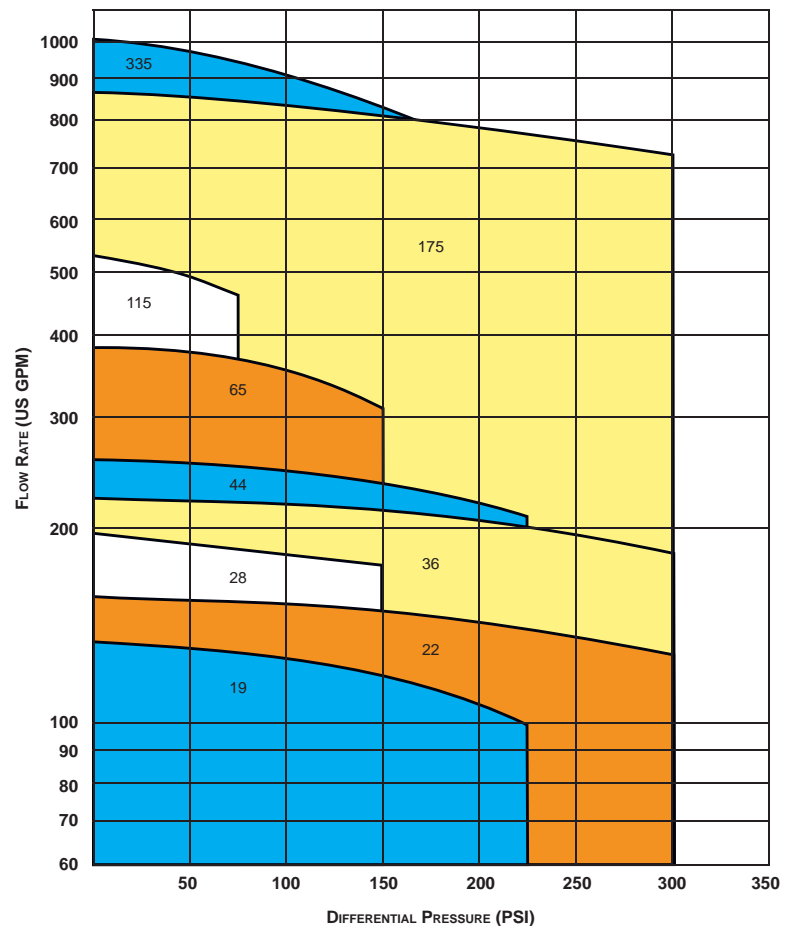
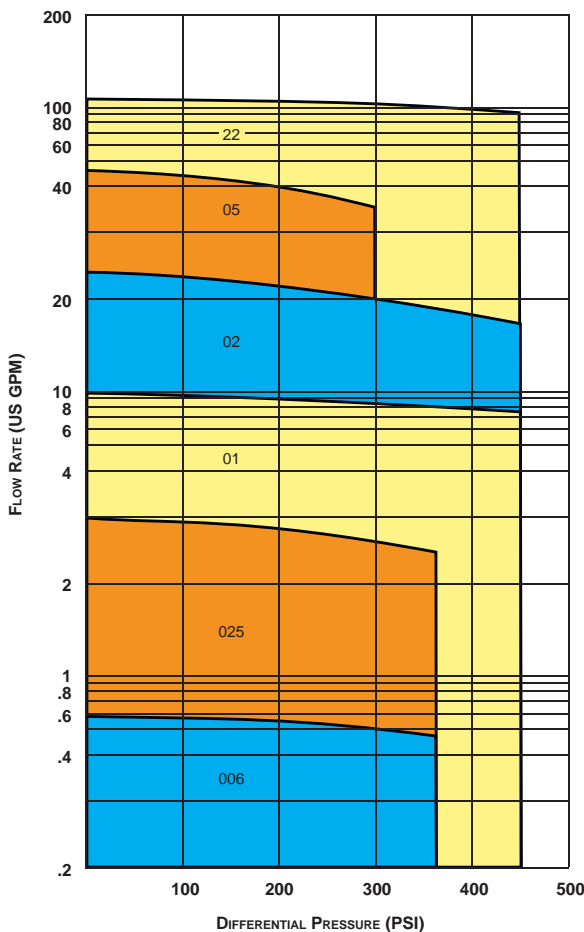

## A Broad Selection of Capacities and Pressure Ratings

Pump Element	006	025	01	02	05	12	19	22	28	36	44	65	115	175	335
Theoretical Capacity (Gal per 100 Rev)	.06	.25	1	2	5	12	19	22	28	36	44	65	115	175	335

# A full range of pumps & parts for your existing PC installations

**Roper Pump can supply you with  
spare parts for your existing PC Pumps:**

- rotors
- shafts
- stators
- pins/bushes
- coupling rods
- gear joints
- associated hardware



**Spare parts are available for  
these brands of PC pumps:**

**Moyno® Tarby® Liberty Eagle Continental**

Our rotors, stators, drive shafts and drive end assemblies can be modified to suit conditions for almost any application. Rotors are made of hard chrome-plated hardened alloy steel (for maximum abrasion resistance), or hard chrome-plated 316 stainless steel (for corrosion and abrasion resistance).

## **Drop-in Replacement Pumps**

Roper Pump offers complete drop-in replacement pumps to fit your existing piping and baseplate. Our pin joint and gear joint PC pumps are available in a wide range of sizes and capacities matching the most commonly installed models.

Our customer service specialists will help you determine the correct part numbers in order to provide suitable Roper spare parts.



© 2007 by Roper Pump Company  
® Roper Pumps is a registered trademark of the Roper Pump Company.  
Moyno® is a registered trademark of Robbins & Myers, Inc.  
Tarby® is a registered trademark of Tarby, Inc.  
Roper Pump is not a distributor or manufacturer for Moyno® or Tarby®.

# ROPER PUMP COMPANY

The Leading Force Behind Liquids™



Roper Pump Company is a global supplier of high quality positive displacement pumps, designed to handle a broad range of industrial applications.

From a small pump company founded in 1857, Roper Pump has grown into a technological leader. With a large installed base, we have both the knowledge and experience to solve your most challenging pumping problems...and our strong global distribution network ensures that your needs are met on time, every time. Our goal is to earn your trust.

Roper Pump products include helical gear pumps, progressing cavity pumps, triple screw pumps, and rotary lobe pumps. Our capability to develop and design custom products for unique applications advances with each new challenge.

## OUR MARKETS

### INDUSTRIAL AND TRANSPORT



Highlighted by the industry leading 3600 series, our ever expanding product line of helical gear pumps, progressing cavity pumps and custom designed positive displacement pumps can provide a pumping solution for even the most challenging industrial applications.

### POWER GENERATION



Roper Pump provides fuel pumps and liquid fuel flow dividers for industrial frame type gas turbines. DuraFlow™ Corrosion-Resistant Flow Dividers resist corrosion and fuel-borne particulate contamination, for reliable startup of liquid fuel systems. We also manufacture seal oil pumps and lube oil pumps for rotating equipment.

### OIL & GAS



Whether it's highly corrosive drilling fluids, or thick and abrasive slurries & sludges, Roper Pump has pumping solutions from the well to the refinery. Our DragonSlayer™ High Performance Power Sections allow mud motors to drill deeper, run at higher temperatures and last longer in the most hazardous and punishing conditions.

### FOOD AND PHARMACEUTICAL



Our ROC® Series pumps are heavy-duty stainless steel gear pumps, ideal for injection and transfer applications of acids and solvents. SP stainless steel rotary lobe pumps are 3A approved and FDA compliant... providing low shear performance in a broad range of viscosities. Our 3600 series gear pumps are a favorite of chocolate processors, offering jacketing for temperature sensitive processes.

### Roper Pump Company

PO Box 269  
Commerce, GA 30529 USA

Customer Service: (706) 336-3359

Technical Support: (706) 336-3334

Fax: (706) 335-5490

sales@roperpumps.com

www.roperpumps.com

DOC# B-PC-R1 05/2007

