

# Positive Displacement Pumps for Sanitary and Industrial Applications

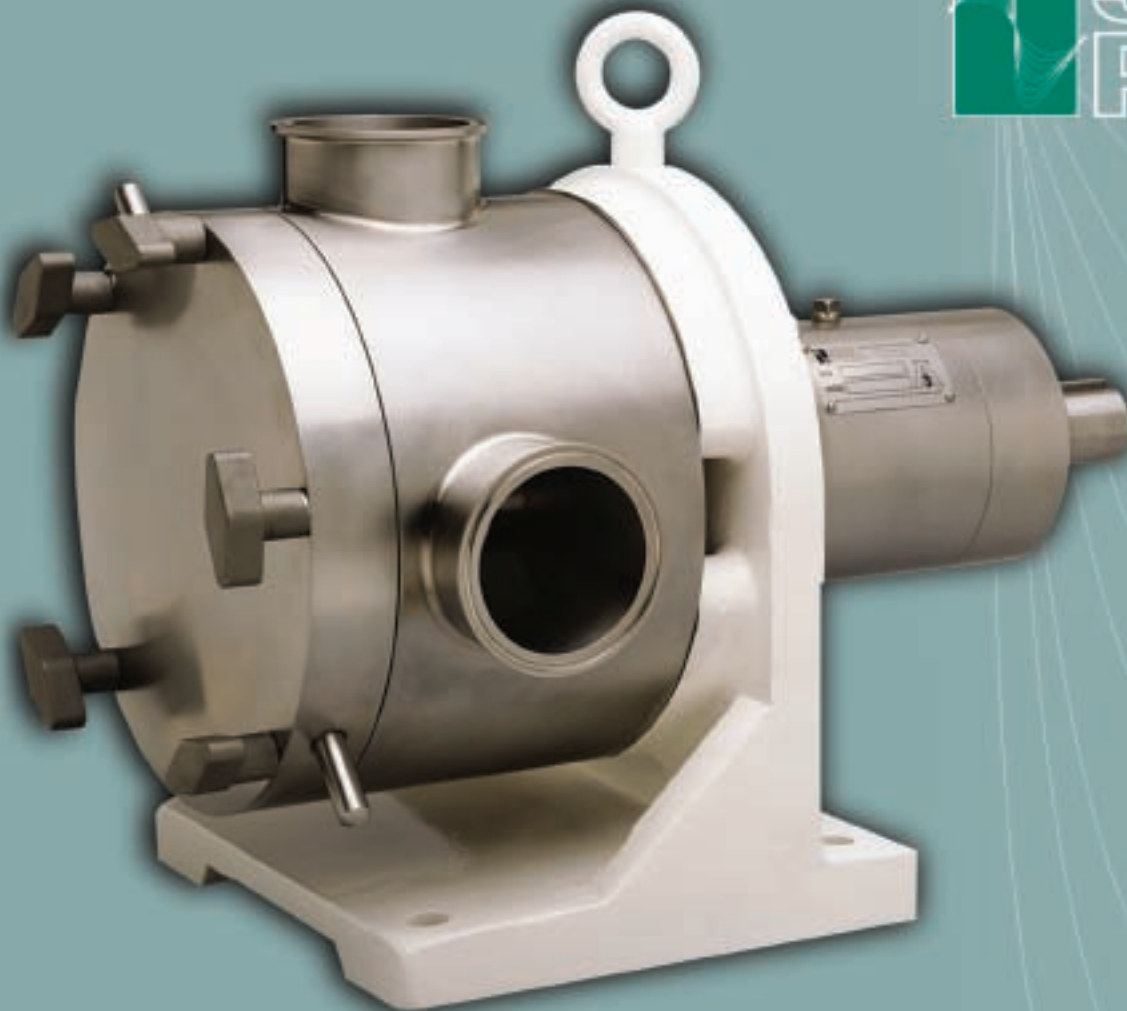

 SINE  
PUMP®

*A Sundyne Corporation Product*

## INNOVATION

Sundyne Corporation, a world leader in innovative pump design, has designed and manufactured the Sine Pump for today's most demanding positive displacement pump applications. Whether the concern is for maintaining the integrity of the product being pumped or simply being able to handle highly viscous products, Sundyne's engineers have overcome the limitations of conventional rotary lobe pumps to create one of the most efficient and reliable positive displacement pumps available.



## APPLICATIONS



**Dairy** — Cheese processors rely on Sine Pump's gentle product handling to reduce fines in fragile cheese curd applications. Dairies use Sine Pump to reduce the shear on milk and cream transfer services. With Sine Pump's superior particulate handling ability, Ice cream processors depend on Sine Pump to feed premium ingredients into their process streams.



**Prepared Foods** — Sine Pump's superior particulate handling enables processors of soups, stews, whole fruit preserves, deli salads, salsa, and diced vegetables to produce a higher quality product for today's discerning buyer.



**Meat & Poultry** — The low shear operation of the Sine Pump reduces "smear" in ground meat applications, and provides greater product integrity in whole muscle slurries. Sine Pump's superior suction capability and low pulsation design provide a smooth, consistent flow of product.



**Bakery** — Sine Pump's superior suction and viscous product handling capability enable bakeries to handle batters, doughs, liquid sweeteners, fruit fillings, creams, and frostings with ease.



**Confectionary** — Simplify the difficulties associated with pumping chocolate, caramel, fondants, cream fillings, heavy syrups, and liquid sugar with Sine Pump's low shear and high suction capability. Sine Pump's ability to operate under high vacuum and optional heating jackets virtually eliminate shaft seal problems.



**Beverage** — Juice concentrate processors achieve higher flow rates and less cavitation with Sine Pump's superior suction capability and hydraulic design. Yeast slurries, beer, and wine applications benefit from Sine Pump's gentle handling design.



**Cosmetics** — Eliminate viscosity changes, product separation, and air entrainment often associated with pumping creams, lotions, toothpaste, shampoo, conditioners, hair gels, and shaving gels. Sine Pump's low shear and superior suction handling capability allows highly viscous ointments and petrolatum products to be pumped with ease.



**Pharmaceuticals** — Improve production volume and product yield when pumping viscous syrups, ointments, pastes, delicate crystalline slurries and shear sensitive cultures with Sine Pump's low shear, gentle handling design and strong suction capability.



**Industrial** — Sine Pump's low shear design and superior viscous product handling capability provide industrial processors with the ideal solution for their resin, adhesive, polymer, paper coating, and latex applications.



## SIMPLICITY OF DESIGN

Sine Pump's exclusive single shaft and single sinusoidal rotor are the centerpieces of Sine Pump's innovative, simple design. With a single shaft and rotor, there is no need for the complex timing gears and multiple seals associated with conventional rotary lobe pumps. One rotor, one shaft, and one seal equate to simple and economic maintenance.

## PRINCIPLES OF OPERATION

- Sine Pump's exclusive sinusoidal rotor creates four separate and symmetrical pumping chambers.
- These pumping chambers pass through the replaceable liners providing the positive displacement of product from the suction side to the discharge side of the Sine Pump. As one chamber discharges product, another chamber is filling with product at the exact same rate.
- The scrapergate shuttles back and forth along the sinusoidal rotor-preventing product from short cycling from the discharge back to the lower pressure suction side of the pump.
- Sine Pump's large pumping chambers maintain a constant volumetric displacement throughout the entire pumping cycle. This eliminates product compression and minimizes damage to large particulates. Constant volumetric displacement contributes to Sine Pump's low pulsation and ability to provide meterable, reproducible flow characteristics.

## FEATURES AND BENEFITS

Today's Sine Pump is the result of over 20 years of product innovation and development. Our efforts have yielded not only some of the most reliable pumping technology available, but also some of the most efficient. Processors will benefit from faster processing and less waste while producing a higher quality product. Here are a few of the ways Sine Pump's advanced design can benefit your process.

**Low Shear** — The gentle, undulating contour of the unique Sine Pump rotor transports your product through the pump without product compression, maintaining your product's viscosity profile, texture, coloration and value.

**Superior Suction** — Capable of pulling vacuum lifts to 30 feet of water (28" Hg), Sine Pump's superior suction capability enables processors to pump highly viscous products and virtually eliminate the noise from cavitation.

**Low Pulsation** — Sine Pump's single rotor design maintains a constant volumetric displacement throughout the pumping cycle, providing a smooth and consistent flow profile without the pulsation spikes typically associated with conventional rotary pumps.

**Gentle Handling** — Sine Pump has set the standard for handling large and fragile particulates without damage. Benefiting from large pumping chambers and the gentle wave action of the sinusoidal rotor, the Sine Pump is unrivaled in its ability to preserve and maintain product integrity.

**Simple, Economical Maintenance** — Sine Pump has been designed to be fully maintainable in the field. With Sine Pump's unique "software" design, pump overhauls can be preformed inline within minutes, bringing the Sine Pump back to "as new" specifications. Gone are the costly repairs associated with sending your pump back to the factory for rebuild.

## TYPICAL CROSS SECTION

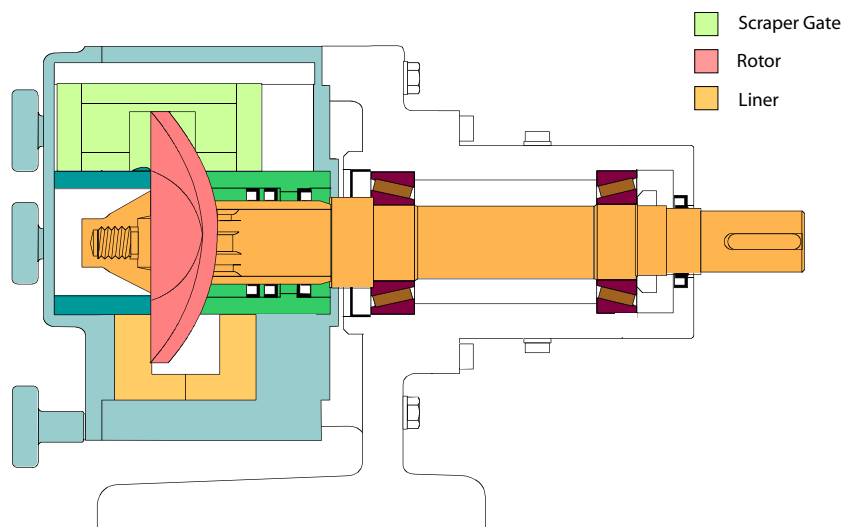

# MR SERIES

## Medium Duty Sanitary Pumps for the Food and Beverage Applications

### DESIGN ADVANTAGES

- Powerful suction for viscous products
- Low pulsation for smooth, consistent flows
- Low shear for fragile and shear-sensitive products
- Single shaft for simple, economical maintenance
- Replaceable wear parts for maintenance in the field
- 3A certified



### TYPICAL APPLICATIONS

- Cheese, Curd & Whey, Cottage Cheese, Butter, Yogurt
- Fruit Concentrates, Syrups, Beer, Wort, Yeast
- Batter, Frosting, Fillings, Slurries
- Soups, Stews, Deli Salads
- Chocolate, Caramel, Fillings, Syrups

MR SERIES SPECIFICATIONS								
Model	Displacement per Revolution Gallons - Liters	Max Speed*	Pressure to PSI - Bar	Capacity GPM - M3/HR	Particulate Size to Inches - MM	Inlet Outlet	Temp Range °F - °C	Weight LB - KG
<b>MR120</b>	.03 GAL (.106 liters)	600 RPM	150 PSI (10.3 BAR)	18 GPM (4.1 M3/HR)	.25 IN (6.5 MM)	2"	-40F TO 266F (1300C)	68 LB (31 KG)
<b>MR125</b>	.06 GAL (.224 liters)			36 GPM (8.2 M3/HR)	.50 IN (12.5 MM)	2.5"		125 LB (57 KG)
<b>MR130</b>	.12 GAL (.470 liters)			74 GPM (16.8 M3/HR)	.75 IN (19 MM)	3"		240 LB (109 KG)
<b>MR135</b>	.23 GAL (.875 liters)			138 GPM (31.3 M3/HR)	1.25 IN (31 MM)	3"		270 LB (123 KG)
<b>MR150</b>	.47 GAL (1.78 liters)			282 GPM (63.9 M3/HR)	2 IN (50 MM)	4"		460 LB (209 KG)
<b>MR160</b>	.67 GAL (2.50 liters)		100 PSI (6.9 BAR)	402 GPM (91.2 M3/HR)	2.5 IN (63 MM)	6"		750 LB (340 KG)

\* For longest service life, pump speed should not exceed 400 RPM



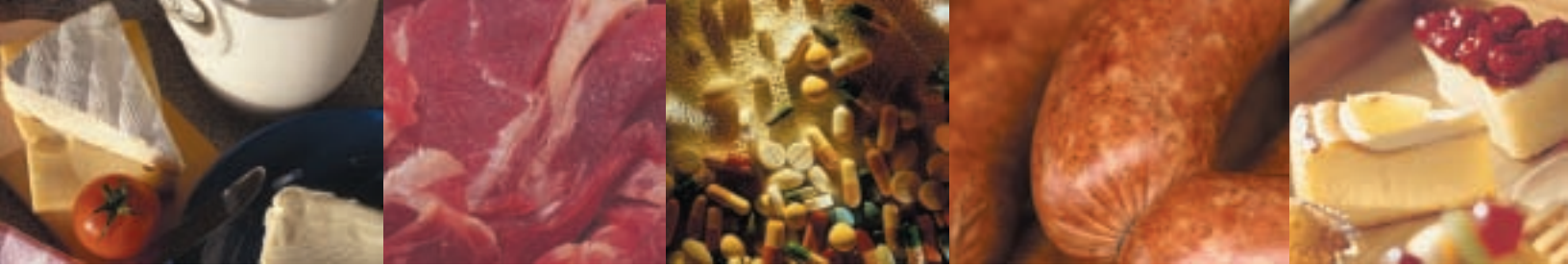

## OPTIONS

- **Jacketing**

Sine Pump's unique single shaft design lends itself to a more effective heating and cooling jacket system. Sine Pump's housing jacket is buried deep within the pump body, providing fast response when maintaining stringent temperature profiles or in molten product applications. For additional temperature control in molten applications, Sine Pump also offers a front cover jacket to keep the product totally surrounded in heat transfer fluid.

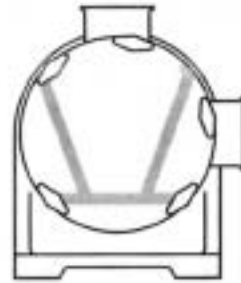

**Front Cover**

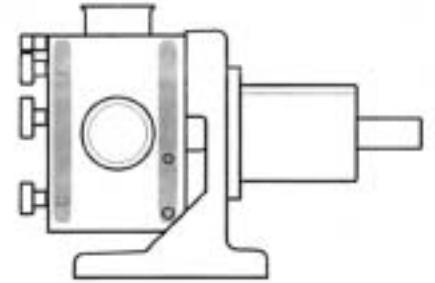

**Front Cover & Pump Housing**

- **Seal Systems**

Unlike conventional rotary lobe pumps using two shafts and two seals, Sine Pump's single shaft design reduces seal concerns in half. Sine Pump's standard triple lipseal system is the seal system of choice for most food and beverage applications. Single o-ring and single mechanical seal systems are available as required.

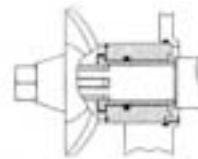

**Single O-Ring**

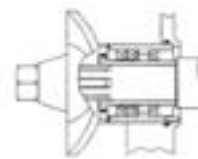

**Lipseal**

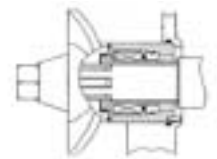

**Mechanical Seal**

- **Nozzles**

Sine Pump comes standard with either Tri-Clamp or Bevel Seat connections. I-Line, European DIN, SMS, ANSI flanges are available upon request.

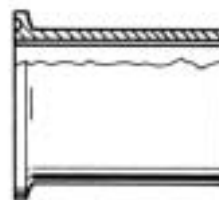

**Tri-Clamp®**

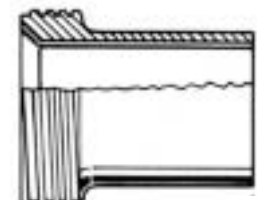

**Bevel Seat**

- **Nozzle Orientation**

Sine Pump's nozzles are oriented 90 degrees to each other and may be easily located at 45 degree increments to fit your exact piping requirements. The Sine Pump may be operated in a clockwise or counter-clockwise direction.

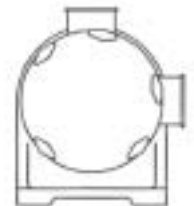
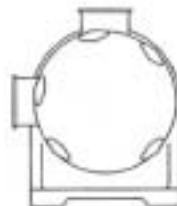

# MR SERIES PERFORMANCE CURVES

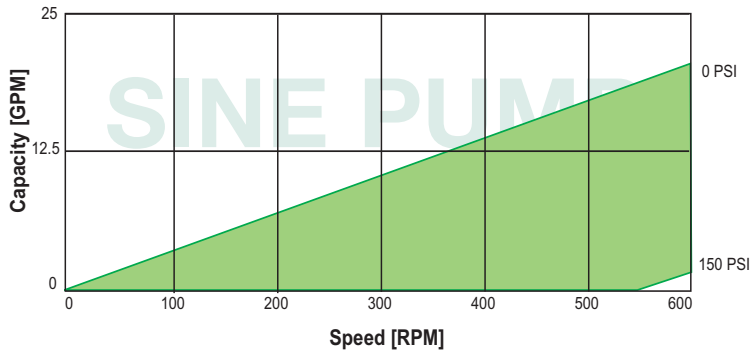

**MR120**

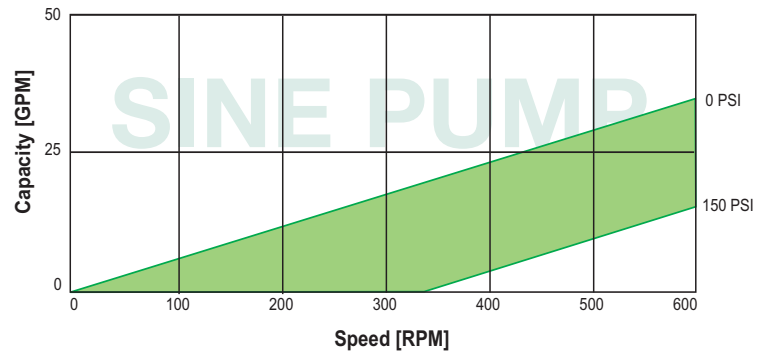

**MR125**

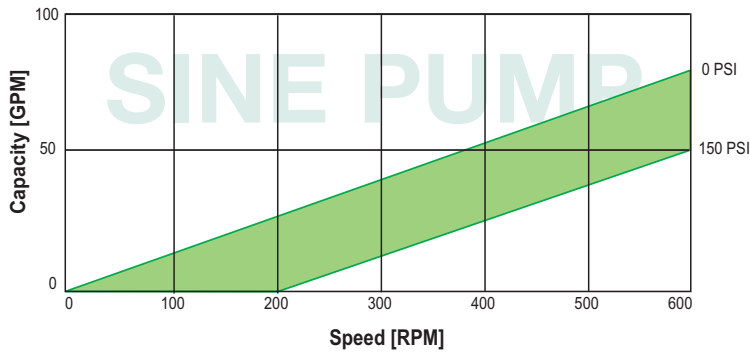

**MR130**

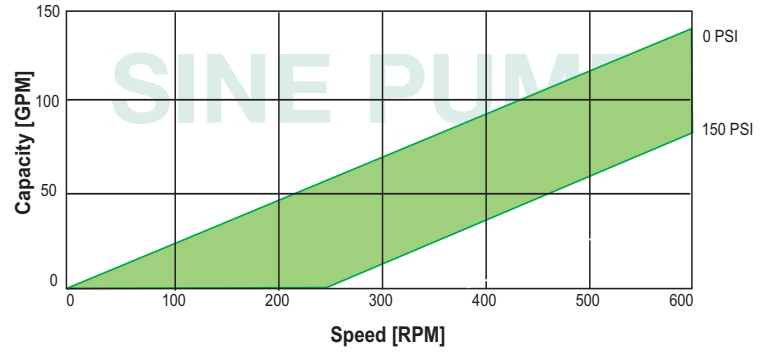

**MR135**

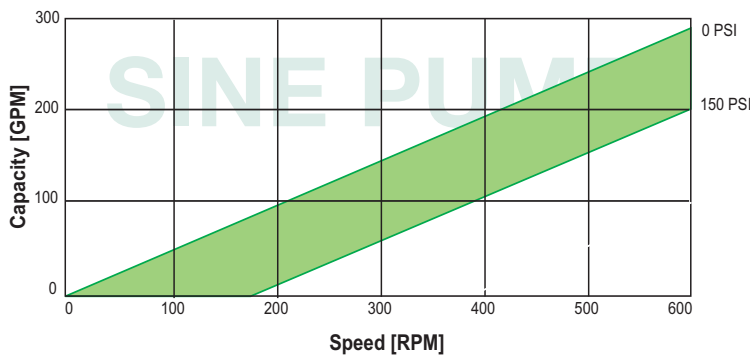

**MR150**

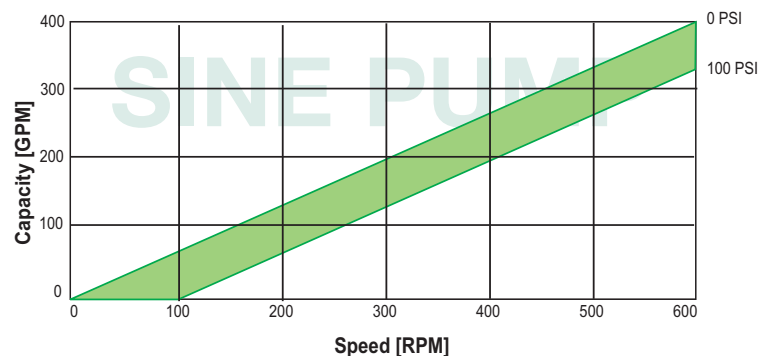

**MR160**

# RF SERIES

## Rectangular Flange Pumps for Meat and Poultry Applications

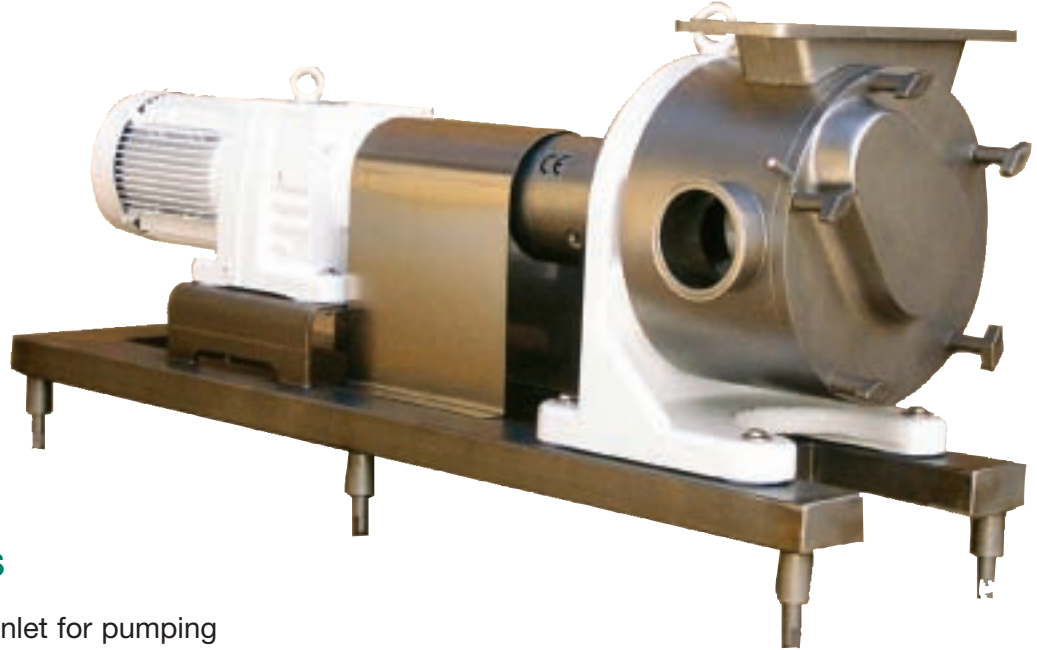

### DESIGN ADVANTAGES

- Large rectangular Inlet for pumping highly viscous materials
- Powerful suction minimizing the need for an auger feeder
- Low pulsation for smooth consistent flows
- Low shear for fragile and shear sensitive products
- Single shaft for simple, economical maintenance
- Replaceable wear parts for maintenance in the field
- 3A certified

### TYPICAL APPLICATIONS

- Ground Seasoned Meats
- Sectioned Whole Muscle Mixtures
- Fine Meat Emulsions
- Fish & Poultry Chunks
- Feeding CHUB and LINK Machines

RF SERIES SPECIFICATIONS							
Model	Displacement per Revolution LB - KG	Pressure to PSI - Bar	Maximum Capacity LBS/HR - M3/HR	Particulate Size to Inches - MM	Inlet Outlet	Temp Range °F - °C	Weight LB - KG
MR135RF	2.3 LB (1.0 KG)	150 PSI (10.3 BAR)	14,000 LBS/HR (6,350 KGS/HR)	1.25 IN (31 MM)	(2.5" x 9.25") x 3" (34MM x 235MM) x 3"	-40F (-40C) TO 266F (130C)	270 LB (123 KG)
MR150RF	4.7 LB (2.0 KG)		28,000 LBS/HR (12,700 KGS/HR)	2 IN (50 MM)	(3.5" x 11") x 4" (90MM x 280MM) x 4"		460 LB (209 KG)
MR160RF	6.7 LB (3.0 KG)	100 PSI (6.9 BAR)	40,000 LBS/HR (18,144 KGS/HR)	2.5 IN (63 MM)	(4.63" x 9.44") x 6" (118 MM x 240MM) x 6"		730 LB (330 KG)

# SPS SERIES

## Heavy Duty Pumps for Sanitary and Industrial Applications

### DESIGN ADVANTAGES

- Heavy duty construction for higher pressure applications
- Powerful suction for viscous products
- Low pulsation for smooth, consistent flows
- Low shear for fragile and shear sensitive products
- Single shaft for simple, economical maintenance
- Replaceable wear parts for maintenance in the field

### TYPICAL APPLICATIONS

- Silicone, Silicone Adhesives
- Monomers, Polymers
- Latex
- Gelatin
- Resins

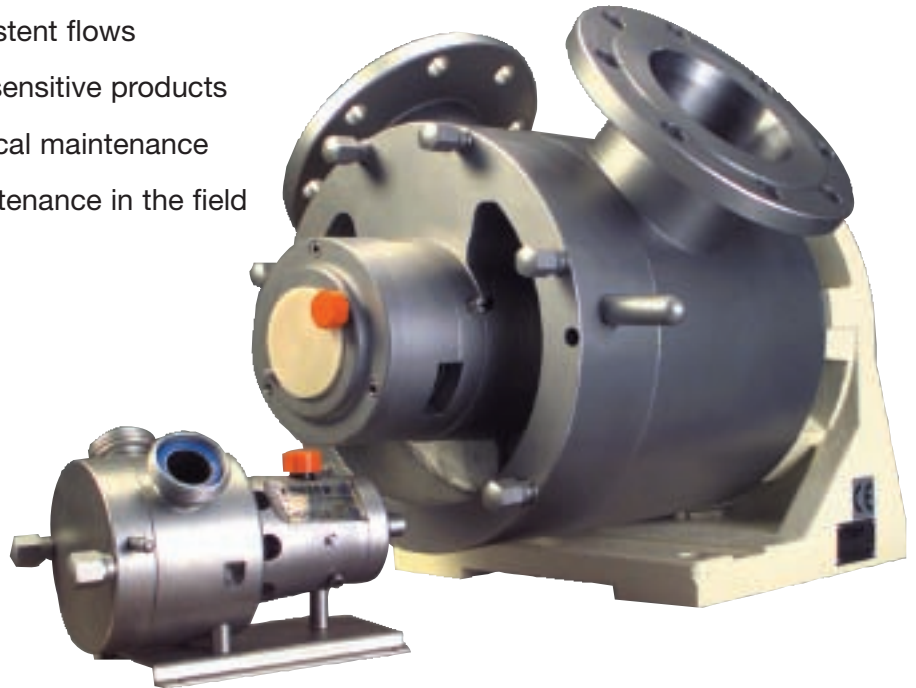

### OPTIONS

- Front cover and housing jackets to maintain constant product temperature
- Custom seal systems

SPS SERIES SPECIFICATIONS								
Model	Displacement per Revolution Gallons - Liters	Max Speed*	Pressure to PSI - BAR	Capacity GPM - M3/HR	Particulate Size to Inches - MM	Inlet Outlet	Temp Range °F - °C	Weight LB - KG
SPS1	.015 GAL (.06 liters)	800 RPM	150 PSI (10.3 BAR)	12 GPM (2.72 M3/HR)	.19 IN (4.7 MM)	1"	-40F (-40C) TO 212F (100C)	33 LB (15 KG)
SPS2	.03 GAL (.11 liters)	600 RPM	217 PSI (15 BAR)	18 GPM (4.1 M3/HR)	.25 IN (6.5 MM)	2"		50 LB (23 KG)
SPS3	.12 GAL (.45 liters)			74 GPM (16.8 M3/HR)	.75 IN (19 MM)	3"		176 LB (80 KG)
SPS4	.28 GAL (1.05 liters)			168 GPM (38.1 M3/HR)	2 IN (50 MM)	4"		352 LB (160 KG)
SPS6	.67 GAL (2.50 liters)			402 GPM (91.2 M3/HR)	2.5 IN (63 MM)	6"		860 LB (390 KG)

\* For longest service life, pump speed should not exceed 400 RPM



# SPS SERIES PERFORMANCE CURVES

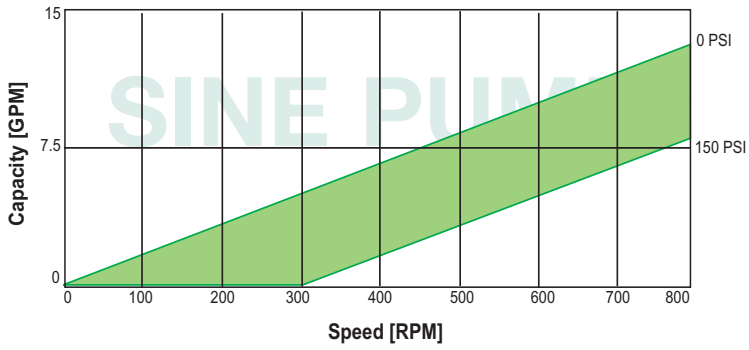

**SPS1**

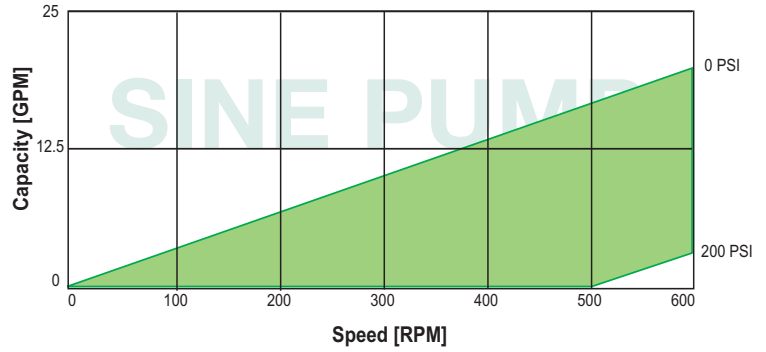

**SPS2**

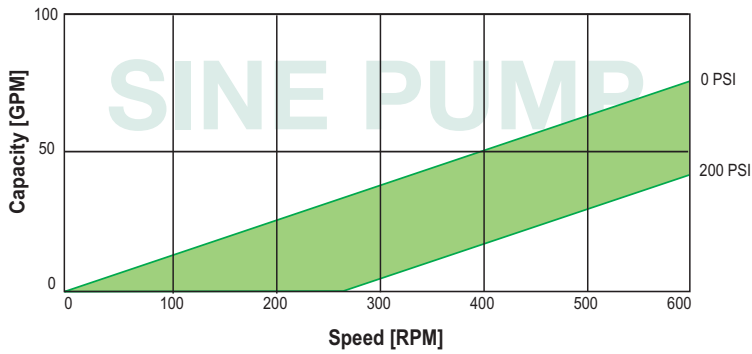

**SPS3**

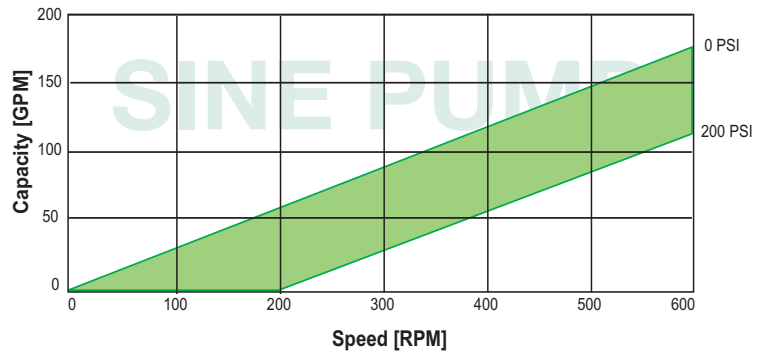

**SPS4**

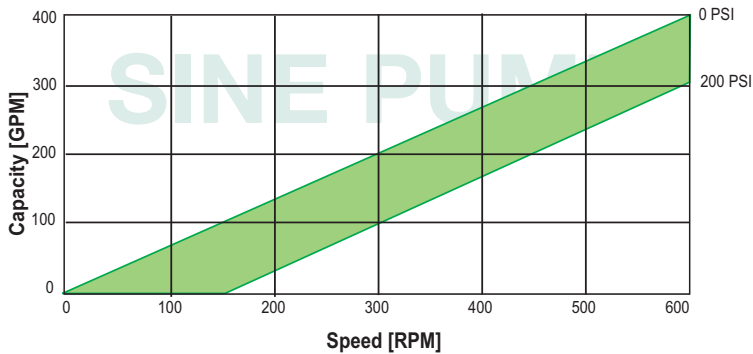

**SPS6**

NOTE: Please contact Sine Pump or your local Sine Pump representative/distributor for certified performance data.



# EC SERIES

## *Economical Positive Displacement Pumps for Sanitary Applications*

### FEATURES AND BENEFITS

- All stainless steel pump and bearing housing
- Low cost for less demanding applications
- Powerful suction for viscous products
- Low pulsation for smooth consistent flows
- Low shear for fragile and shear sensitive products
- Single shaft for simple, economical maintenance
- Replaceable wear parts for maintenance in the field
- 3A Certified

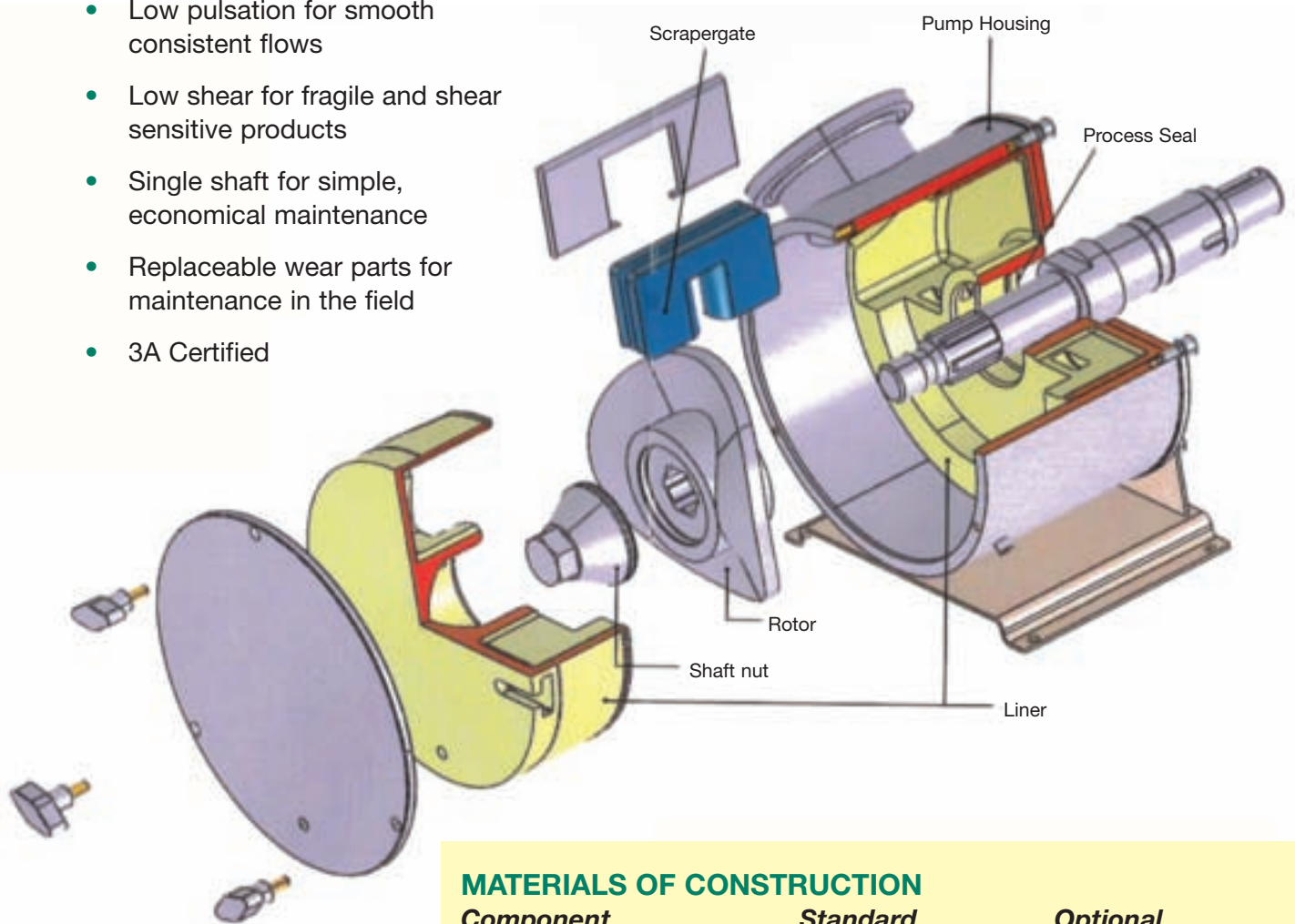

### MATERIALS OF CONSTRUCTION

<b><u>Component</u></b>	<b><u>Standard</u></b>	<b><u>Optional</u></b>
Pump/Bearing Housing	316SS	
Liners	Polyamide	
Scrapergate	Polyamide	
O-Rings	Buna	EPDM, Viton
Seal Type	Lip	Single Mechanical
Nozzles	Tri-Clamp	Bevel Seat

# EC SERIES

## Economical Positive Displacement Pumps for Sanitary Applications

### DIMENSIONS

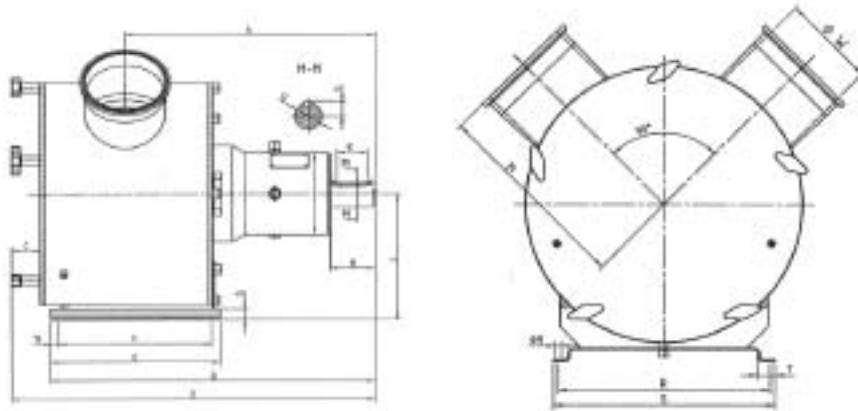

		A	B	C	D	E	F	G	H	I	K
<b>EC25</b>	IN	9.25	11.42	1.38	13.35	7.28	6.11	0.59	2.05	3.46	1.27
	mm	235	290	35	339	185	155	15	52	88	32.2
<b>EC40</b>	IN	11.65	15.04	1.38	16.97	7.87	6.69	0.79	1.97	5.12	1.19
	mm	296	382	35	431	200	170	20	50	130	30.2
<b>EC60</b>	IN	18.23	23.71	2.13	25.75	12.41	11.22	0.79	3.22	5.91	2.21
	mm	463	602	54	654	315	285	20	82	150	56.2
		L	M	P	R	S	T	U	V	W	NOZZLES
<b>EC25</b>	IN	4.67	5.22	9.88	4.92	5.51	0.91	1.1	0.67	2.37	2.5"
	mm	118.5	133	251	125	140	23	28	17	60.2	2.5"
<b>EC40</b>	IN	6.81	7.04	13.86	10.04	10.63	1	1.5	0.87	3.83	4"
	mm	173	179	352	255	270	25.5	38	22	97.4	4"
<b>EC60</b>	IN	9.21	11.61	20.86	12.41	12.99	1	1.97	1.12	5.78	6"
	mm	234	295	530	315	330	25.5	50	28.5	146.8	6"

### SPECIFICATIONS

Model	Displacement per Revolution Gallons - Liters	Max Speed	Pressure to PSI - Bar	Maximum Capacity GPM - M3/HR	Inlet Outlet	Temp Range °F - °C	Weight LB - KG
<b>ec25</b>	.06 GAL (.224 liters)	600 RPM	90 PSI (6 BAR)	36 GPM (8.2 M3/HR)	2.5"	-40F (-40C) TO 212F (100C)	41 LB (19 KG)
<b>ec40</b>	.23 GAL (.875 liters)			138 GPM (31.3 M3/HR)	4"		115 LB (52 KG)
<b>ec60</b>	.92 GAL (3.50 liters)			552 GPM (125.2 M3/HR)	6"		247 LB (135 KG)

**QUALITY IN. QUALITY OUT.**



Outside of North America, Sine Pump can be found by contacting:  
Postfach 100, 74358 Illsfeld • Tel 07062/9560-0 • Fax 07062/64593 • eMail info@maso.de



**[www.sundyne.com](http://www.sundyne.com)**

Manufacturers representatives, distributors service centers and direct offices are located throughout the world. For a complete list, visit our website.



Sundyne Corporation • Arvada, CO 80007 USA • +1-303-425-0800 • FAX: +1-303-425-0896 • [www.sundyne.com](http://www.sundyne.com)

• ANSIMAG • ANYSPEED • CASTER • HMD/KONTRO • MASO/SINE • SCMP • COMPRESSORS • SUNDYNE • SUNFLO •