

TS-171
Rev. B
Type S High Pressure Flowmeters
15.88mm x 25.40mm (5/8" x 1")

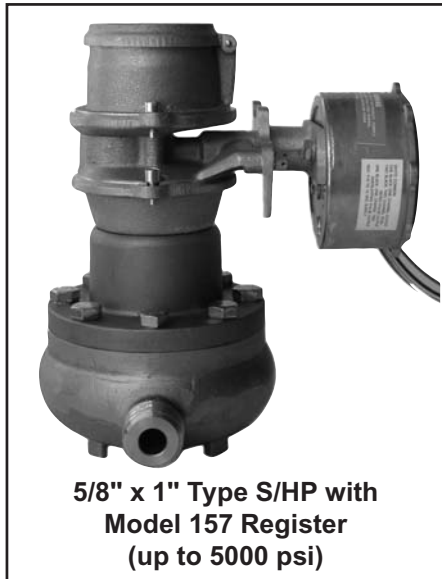

TYPE S HIGH PRESSURE FLOWMETERS



- * Heavy Duty Design Withstands High Pressure
- * Standard NPT Fittings For Easy Installation
- * Positive-Displacement Disc Principle
- * Change Gears For Positive Calibration
- * Accuracy of 100% \pm 1.0%
- * Repeatability 100% \pm 0.1% of Rate
- * Minimal Maintenance
- * Compact Design

SPECIFICATIONS

DESCRIPTION

Actaris Type S Nutating Disc High Pressure (HP) Flowmeters are precision-constructed measuring instruments used for accurate measurement of liquids at high pressures. The 5/8" x 1" Type S/HP measures liquids at pressures up to 345 bar (5000 psi).

DESIGN FEATURES

The nutating disc positive displacement measuring chamber is accurate and dependable with a standard accuracy of 100% \pm 1.0% and repeatability of 100% \pm 0.1% of rate.

The double case design of Type S/HP flowmeters allow liquid to surround the measuring chamber at line pressure. Therefore, the measuring chamber is not subjected to pressure distortion which is the major source of flowmeter damage. Installation of Type S/HP flowmeters may be in any position or location in either an existing or a new system, downstream from the pump.

FLEXIBILITY

Type S/HP Flowmeters are used in diverse operations from monitoring water injection at water flood input wells for secondary oil recovery to determining the usage of costly printing inks as ink is pumped through pipes to the press fountains.

The rugged corrosion resistant steel outer body and cover, with durable bronze gear train and measuring chamber, allow the 5/8" x 1" Type S/HP to additionally handle a wide variety of mild acidic, erosive, petroleum and other high viscosity liquids. Other uses of the 5/8" x 1" Type S/HP include high viscosity thixotropic printing inks at 135 - 345 bars (2000 - 5000 psi) and high viscosity greases and lubricants. The 5/8" x 1" Type S/HP flowmeters are universally accepted for precise ink measurement in heat set and web fed off-set color printing presses for quality control and billing operations.

LONG SERVICE LIFE

The rugged construction of Type S/HP flowmeters assures simple, economical and low maintenance.

POSITIVE AND ACCURATE REGISTRATION

Positive adjustment through calibration (change) gears eliminate errors caused by vibration, liquid shock and weather conditions, and reduce the potential for tampering. Due to the nature of higher viscosity liquids, the minimum operating range may be reduced by 75% or more.

SIMPLE DESIGN

The Actaris Type S/HP flowmeter is both simple in design and easy to service. Normal maintenance can be accomplished in less than 10 minutes. In addition, the inlet and outlet connections (spuds) are machined to 1" NPT for use with commercially available high pressure couplings.

ACCESSORIES

A simple, direct-reading totalizer register (Model 157) with easy-to-read numerals provides a convenient means of checking the quantity delivered. In addition, an adapter can be added to incorporate a pulse transmitter for remote batching or totalization.

ACCURACY

5/8" x 1" Type S/HP Flowmeter:

- Low viscosity range (0.5-3000 cPs): 100% \pm 1.0% of rate, based on a 10:1 turndown. Q max 76 LPM (20 US GPM) to Q min 7.6 LPM (2 US GPM). For specific ranges with increased viscosity and reduced variables, accuracies of 100% \pm 0.5% are obtainable with field calibration.
- High viscosity range (3000 cPs and above) first, Q max and Q min are reduced by 75%: 19.0 to 0.95 LPM (5.0-0.25 US GPM). Standard accuracy is 100% \pm 1.0% of rate. Enhanced accuracies are not addressed due to unpredictable variables in many thixotropic liquids and viscosity changes.
- Repeatability is 100% \pm 0.1% of rate.

PRESSURE LOSS CURVES FOR WATER

5/8" X 1" TYPE S/HP

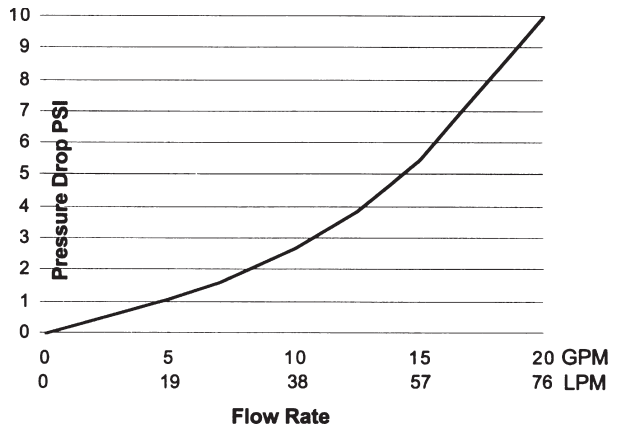

TYPICAL INSTALLATION

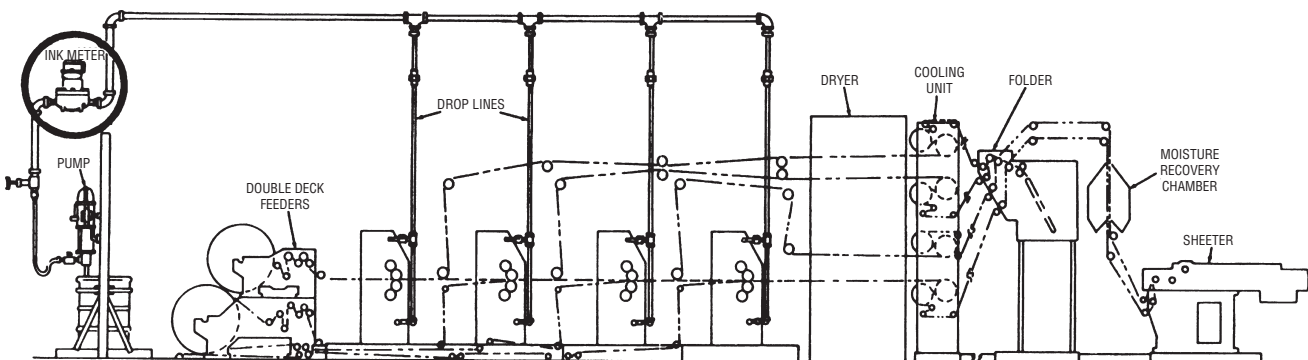

FLOWMETER OPERATING SPECIFICATIONS

CATEGORY	5/8" x 1" TYPE S/HP FLOWMETER		
METER	Type of Measuring Element	Double Case Nutating Disc	
	Size of Element	80.54 cc (4.91 in ³)	
	End Connections a. Threaded b. Flanged	1" External NPT Not Applicable	
	Temperature Rating (T Max)	121°C (250°F)	
	Pressure Ratings P Max P Min	345 bar (5000 psi) @ 121°C Dependent upon through-put and viscosity	
	Flow Range (Q Max) (Q Min)	Below 3000 cPs: 76 LPM (20 GPM) Above 3000 cPs: 19 LPM (5 GPM) Below 3000 cPs: 7.6 LPM (2 GPM) Above 3000 cPs: .95 LPM (.25 GPM)	
	Totalized Units (min)	1 Gallon or 10 Litres, 10 Kilograms or 10 Pounds	
	Enclosure Class	Totally mechanical. If interfaced with a pulse transmitter, the rating of the device applies.	
	Power Supply	None, unless fitted with a pulse transmitter, then the rating of the installed device applies.	
	Main Body Material	Corrosion Resistant Steel	
	Main Body Cover Material	Corrosion Resistant Steel	
	Disc Piston	Ryton	
	Shaft Material	Stainless Steel	
	Gasket Material	Buna-N	
	Type of Coupling	Mechanical	
	COUNTER	Register Type	Model 157 Totalizer
		Totalizer	Model 157: 7 digits
Reset		Not Applicable	
Capacity		Totalizer 9999999	
Set-Stop		Not Applicable	
Flow Units		Only with pulse transmitter and BATCHMATE Batch Control Computer	
Shut-Off Valve		Not Applicable	
OPTIONS	Switch a. Single Stage b. Double Stage	Not Applicable Not Applicable	
	Transmitter Type	Model 35 and Model 35 HR (Consult TS-510)	
	Transmitter Output	10 or 100 pulses per gallon OR 1 or 10 pulses per litre, pound or kilo (See TS-510)	
	Air Eliminator	Not Applicable	
	Strainer Size & Mesh	Not Applicable	
Manufacturer	Actaris U. S. Liquid Measurement Division, Inc.		
Model Number	TSHP062-XXXX		

DIMENSIONAL DATA

5/8" x 1" Type S/HP with 157 Register

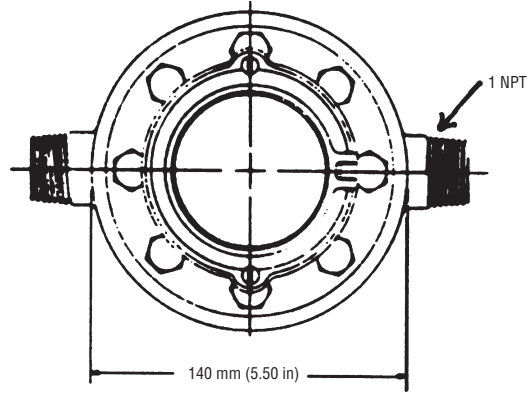
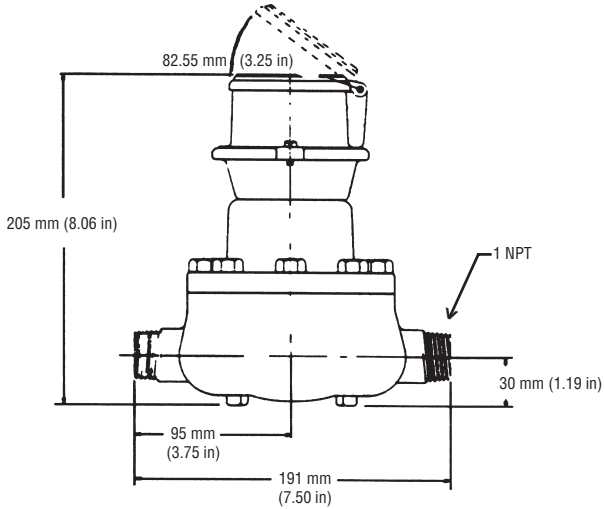

PULSE TRANSMITTER DIMENSIONS 157 Register Adapter with Model 35 or 35 HR Pulse Transmitters

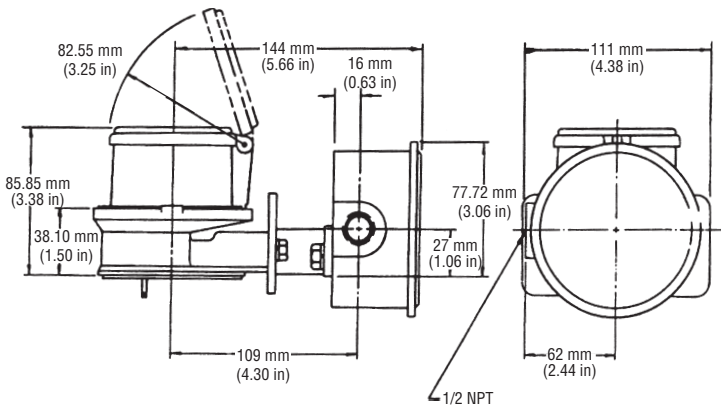

ALTERNATE PULSE TRANSMITTER (Model PE, PES)

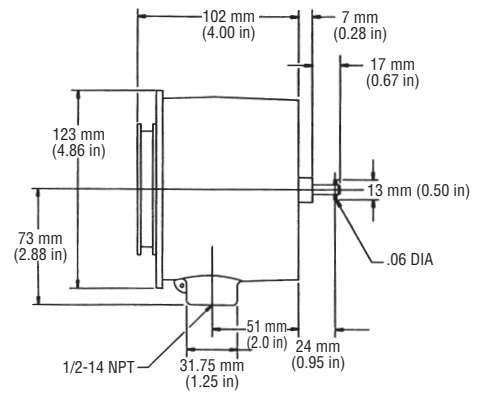

U.S.A./International
1310 Emerald Road
Greenwood, SC 29646-9558
Tel.: Toll-Free (800) 833-3357
(864) 223-1212
Fax: (864) 223-0341

© 2005 Actaris U. S. Liquid Measurement Division, Inc. 400 5/05

Specifications subject to change without prior notification.

