



RCS Actuators

Versatile Automation Solutions

Electric Actuators

Overview/Features & Benefits	3-4
MAR/DCR-10, 50 & 90	5-7
Outline Dimensions (MAR/DCR-10, 50 & 90)	6
Selection Charts	7-8
MAR/DCR-100, 120, 160, 250, 800, 1600 & 4000	9-16
Outline Dimensions (MAR/DCR-100, 120, 160 & 250)	10
Outline Dimensions (MAR/DCR-800).....	11
Outline Dimensions (MAR 1600-65, 4000-160).....	12-13
Selection Charts	14-16
SURE 24/25, 49, 100, 150.....	17-25
Outline Dimensions (SURE 24/25)	18
Outline Dimensions (SURE 65).....	20
Outline Dimensions (SURE 100)	22
Outline Dimensions (SURE 150)	24
Selection Charts	25
CONTROLS	
ACT-100 (Micro-Processor Based Analog Controller).....	26-27
DPC-100 & DPC-120 (Profibus® DP Actuator Controller)	28
DNET115 (DeviceNet™ Actuator Controller)	29
ModBus Actuator Controller	30

RCS Electric Actuators – Exceptional Automation Solutions

RCS actuators, a division of Dresser Natural Gas Solutions, provides exceptional automation solutions for valve and equipment manufacturers and end users in the commercial, industrial, marine, and power applications.

Applicable to a myriad of automation solutions from simple on/off control to severe and critical modulating service, RCS actuators are suitable for use in a wide variety of challenging and hazardous environments. RCS actuators has specialized in offering engineered actuator solutions for unique and unusual applications for over 50 years and are proudly manufactured in America.

Versatile and Reliable Electric Rotary Actuators

The RCS electric actuator rotary product line offers a broad selection of versatile actuator products. Targeted to quarter-turn and multi-turn valves and dampers, RCS actuators are also configurable for use in automating other types of flow control devices, and cover torque ranges from 25 lb. in. to 48,000 lb. in. with torque ranges from 120 lb. in. to 48,000 lb. in. with stroke speeds ranging from 0.5 seconds for 90 degree operation to 160 seconds for 90 degree operation, and for multi-turn versions, from 7.5 to 30 rpm.

The Industry Leader in Spring-Return Actuators for Critical Isolation Service

RCS's SurePowr® spring-return electric actuators utilize heat treated alloy steel springs to assure a reliable mechanical solution for shutoff or isolation situations. This design provides a cost-effective, low maintenance, proven alternative to pneumatic, hydraulic, electro-hydraulic or battery fail-safe methods. The SurePowr series is capable of performance in elevated temperatures up to 400° F (250° C) for one hour without the need for external thermal insulation; up to four hours with external thermal insulation, and also for different durations at higher temperatures in compliance with NFPA 130 and NFPA 502; low temperature versions are also available.

An Extensive Selection of Control Devices and Accessories

RCS offers an extensive selection of electrical and electronic accessories for its actuator selection, including the latest solutions to industry demands for analog and digital control protocols such as Modbus®, Devicenet®, and Profibus DP®, in addition to relays, potentiometers, and other devices.

Features & Benefits

Application Flexibility

RCS actuators from Dresser NGS provide a diverse range of torques, speeds and available voltages. Coupled with an extensive line of control and communication accessories, these actuators offer unique solutions to a host of automation requirements. Standard operation for MAR and DCR models is part turn, reversible with unidirectional and multi-turn options available.

Electric Motors

All RCS electric actuators are powered by an extended duty, high-torque, reversible motor. These motors are suitable for both on/off and positioning applications. Each motor is Class "B" insulated with an internal thermal overload protective device. This device protects the motor if a "stall" condition occurs, thus preventing the motor from overheating which could result in premature motor failure.

Precision Gearing

All gears used in RCS actuators are manufactured from alloy steel. Each gear is precision machined and then heat-treated, giving the gears exceptional strength. Each gear assembly is designed to withstand the stall torque generated by the motor.

Permanent Lubrication

All gear and spring assemblies are permanently lubricated with a high quality lubricant selected to meet a wide range of operational and environmental conditions. Periodic lubrication is not required.

Versatile Installation

All RCS actuators can be installed and operated in any position. This allows flexibility for installation in confined locations or in retrofit applications.

Manual Override

MAR/DCR 10, 50 and 90 models feature a engageable manual override. The actuator gearing is disengaged from the motor, thus the actuator cannot be operated electrically while in manual operation. MAR 100 through 4000 feature a manual override with an automatic electrical safety lockout switch. When the handwheel is engaged, the electrical switch isolates the motor from the supply voltage to prevent electrical operation.

Environmental

With electrostatically applied powder coating, electroless nickel-plated output shafts, and stainless steel external fasteners, optional marine epoxy paint systems or electroless nickel plated enclosures are also available to meet most onshore or offshore conditions.

Position Indication

Mechanical position indicators are standard on every model. An external indicator provides a visual reference for the actuator position.

Simplified Wiring

All RCS actuators feature internal wiring connected to a clearly marked and easily accessible terminal strip to provide for convenient termination of field wiring.

Part-Turn Electric | Multi-Turn Electric

Optional 7" Handwheel Available



NEMA 4/4X Enclosure

Approvals

MAR Models Only
(Canadian Standards Association)
CSA NRTL/C – Enclosure



NEMA 7 Enclosure

Approvals

MAR Models Only
(Canadian Standards Association)

CSA NRTL/C Class I, Division 1,
Groups C & D

CSA NRTL/C Class II, Division 1,
Groups E, F, & G

CSA NRTL/C Approved to UL Standard
No. 429, Electrically
Operated Values

CSA NRTL/C Approved to UL Standard
No. 1203, Electrical
Equipment for use in
Explosion - proof
And Dust - Ignition - proof
Hazardous
(Classified) Locations

Models

MAR-10, 50, 90 – A.C. voltages
DCR-10, 50, 90 – D.C. voltages

Typical Applications

For open / close and positioning
control of:

- Part turn ball, butterfly, choke, or plug valves
- Ventilation dampers
- Select multi-turn valves

Temperature Range

Standard: -40°F to +150°F
-40°C to +66°C

Optional: -60°F to +120°F
-51°C to +49°C

(Note: With heater installed and energized)

Optional: Compliance to NFPA 130 and NFPA 502, capable of operation after exposure to ambient temperature of 482°F (250°C) for a minimum of 1 hour

Voltage

115 VAC, 1 Phase, 50/60 Hz.
230 VAC, 1 Phase, 50/60 Hz.
12 VDC / 24 VDC

Torque Range

30 to 1,000 inch pounds
(3.4 to 113.0 newton meters)

Speed Range

For 60 Hz. operation:
.5 to 60 seconds for 90° revolution
3 to 30 RPM's for multi-turn units

Standard Features

AC Voltages
2 – SPDT Switches, PTC heater
thermostat, manual override
DC Voltages
2 – SPDT (High Current) Switches,
manual override

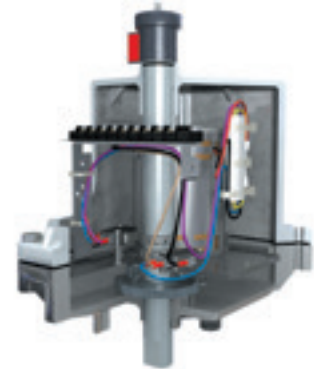

Open/Close

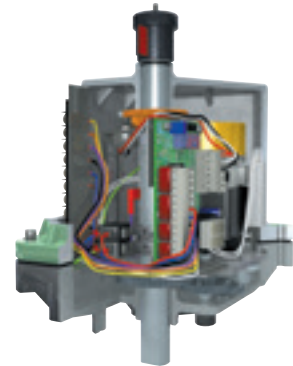

Positioning

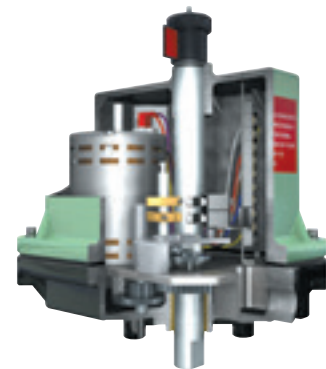

Multi-Turn

Part-Turn Electric | Multi-Turn Electric

Outline Dimensions (Inches) – MAR & DCR 10, 50, & 90

Weight
NEMA 4/4X Enclosure: 12 lbs./5.4 kg
NEMA 7 Enclosure: 16 lbs./7.3 kg

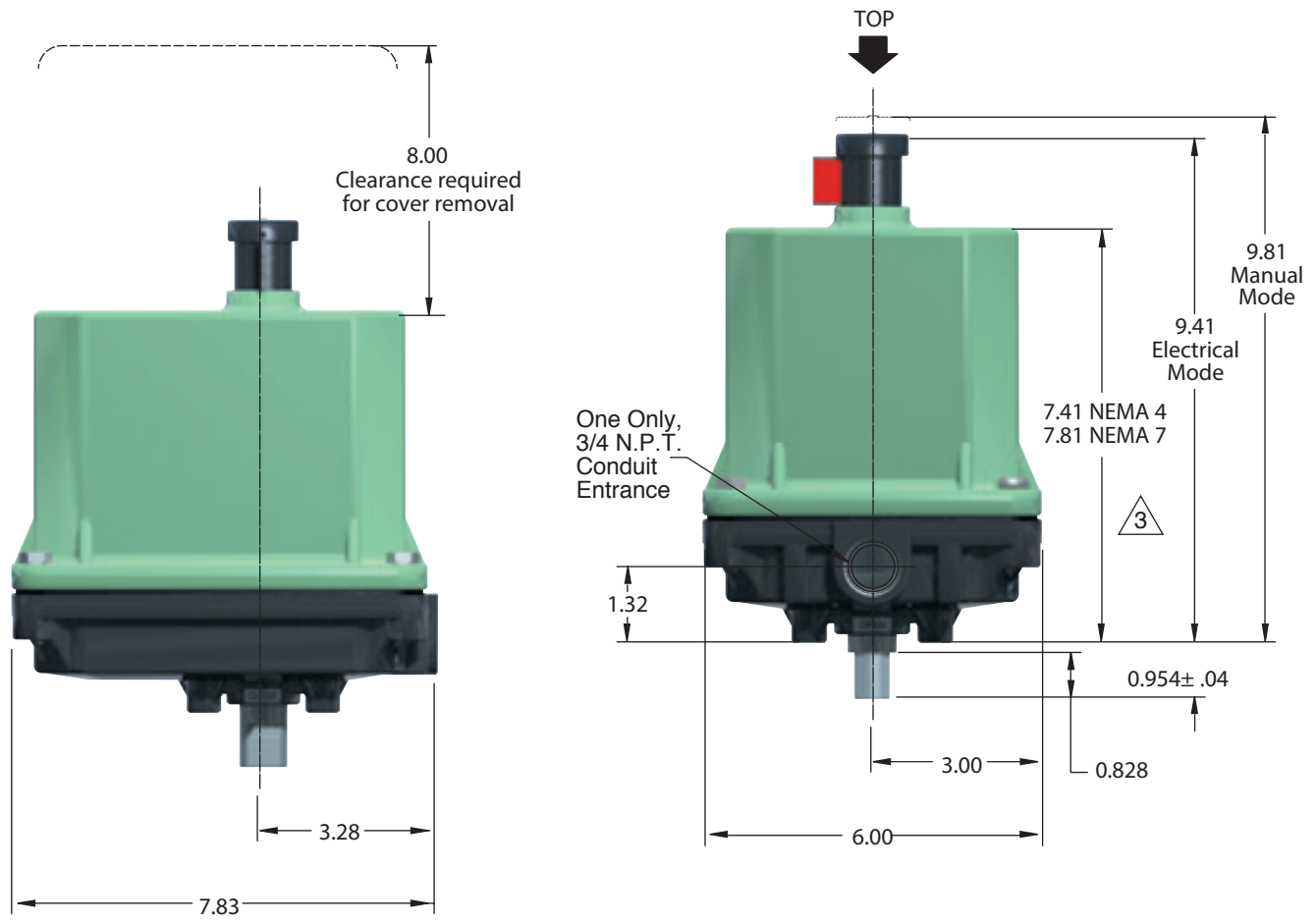

Mounting Geometry - Bottom View

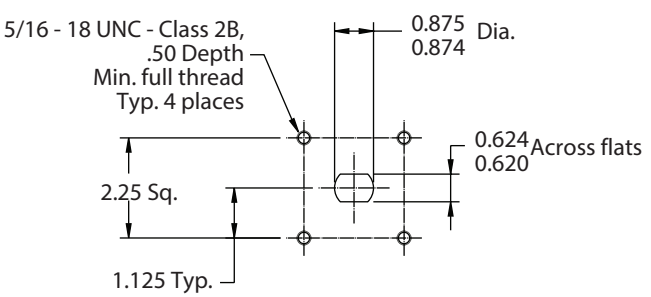

Notes

1. Direction of rotation is based on viewing actuator from top.
2. Drawing shows output shaft in a fully clockwise (closed) position.
3. Actuator shown with indicator in electrical mode.
4. A NEMA 4 control enclosure is shown. Dimensions given are accurate for NEMA 7.

Part-Turn Electric | Multi-Turn Electric

115 & 230 VAC, 1 Phase, 50/60 Hz.

Model	Output Torque Inch Pounds (N.m)	Type	Speed of Operation 60 Hz. (50 Hz.)	Duty Cycle Rating 115 Vac, 1Ph., 50/60 Hz.	Duty Cycle Rating 230 Vac, 1Ph., 50/60 Hz.	Current Ratings 115 VAC		Current Ratings 230 VAC	
						NLA*	LRA*	NLA*	LRA*
MAR 10-.SMT	25 (3.01)	Multi-Turn	30 RPM N/A	25% (2)	25% (2)	0.50	0.82	0.25	0.40
MAR 10-2	120 (13.6)	Part Turn	2 second/90° (2.5 seconds/90°)	50% (1)	50% (1)	0.40	0.60	0.30	0.40
MAR 10-2MT	120 (13.6)	Multi-Turn	7.5 RPM (6.2 RPM)	50% (2)	50% (2)	0.40	0.60	0.20	0.25
MAR 10-10	350 (39.5)	Part Turn	10 seconds/90° (12 seconds/90°)	50% (1)	50% (1)	0.40	0.60	0.20	0.25
MAR 10-30	425 (48.0)	Part Turn	30 seconds/90° (35 seconds/90°)	50% (2)	50% (2)	0.30	0.50	0.20	0.25
MAR 10-60	400 (45.2)	Part Turn	60 seconds/90° (70 seconds/90°)	50% (2)	50% (2)	0.35	0.55	0.20	0.25
MAR 50-.SMT	200 (22.6)	Multi-Turn	30 RPM N/A	25% (2)	25%	1.90	3.10	-	-
MAR 50-2	600 (67.8)	Part Turn	2 seconds/90° (2.5 seconds/90°)	40% (1)	50% (1)	1.60	2.20	0.50	0.95
MAR 50-2MT	600 (67.8)	Multi-Turn	7.5 RPM (6.2 RPM)	40% (2)	50% (2)	1.60	2.20	0.50	0.95
MAR 50-10	600 (67.8)	Part Turn	10 seconds/90° (12 seconds/90°)	50% (1)	50% (1)	0.50	0.80	0.30	0.50
MAR 50-30	700 (79.1)	Part Turn	30 seconds/90° (35 seconds/90°)	50% (2)	50% (2)	0.35	0.55	0.20	0.25
MAR 50-60	600 (67.8)	Part Turn	60 seconds/90° (70 seconds/90°)	50% (2)	50% (2)	0.30	.50	0.20	0.25
MAR 90-5	1,000 (113.0)	Part Turn	5 seconds/90° (6 seconds/90°)	50% (1)	50% (1)	0.55	1.55	0.25	0.85
MAR 90-5MT	1,000 (113.0)	Multi-Turn	3 RPM (2.5 RPM)	50% (2)	50% (2)	0.55	1.55	0.25	0.85
MAR 90-15	1,000 (113.0)	Part Turn	15 seconds/90° (17.5 seconds/90°)	75% (2)	50% (2)	0.50	0.60	0.20	0.35

* (N.L.A.) — No Load Ampere (L.R.A.) — Locked Rotor Ampere (1) — Open/Close Service (2) — Open/Close or Positioning Service

Isolation Relays

To operate multiple actuators in parallel from a single signal requires isolating relays in the actuator or the field wiring.

Duty Cycle

The percentage of time the electric motor is energized vs. the time it is at rest, in reversing duty, and with the actuator running at the rated maximum published torque.

Standard Modulating Duty Rating

12 motor starts (corrections) per minute at the rated duty cycle for that model with the speed of operation a minimum of 15 seconds for 90° or slower with positioning accuracy of (+/-) 1% of total span.

Note — Multi-turn models are available with the following number of turns:

1.4, 5, 8, 13, 18, 26 or 50. This must be specified when the order is placed.

Part-Turn Electric | Multi-Turn Electric

12 & 24 VDC

Model	Output Torque Inch Pounds (N.m)	Type	No Load Speed of Operation	Duty Cycle Rating 12 VDC	Duty Cycle Rating 24 VDC	Current Ratings 12 VDC		Current Ratings 24 VDC	
						NLA*	LRA*	NLA*	LRA*
DCR 10-2	250 (28.2)	Part Turn	.6 seconds/90°	50% (1)	50% (1)	1.00	12.3	0.75	6.80
DCR 10-2MT	250 (28.2)	Multi-Turn	25 RPM	50% (2)	50% (2)	1.00	12.3	0.75	6.80
DCR 10-10	400 (45.2)	Part Turn	6.4 seconds/90°	50% (1)	50% (1)	0.19	3.90	0.08	2.10
DCR 50-2	600 (67.8)	Part Turn	.7 seconds/90°	50% (1)	50% (1)	1.53	22.00	0.75	12.30
DCR 50-2MT	600 (67.8)	Multi-Turn	21 RPM	50% (2)	50% (2)	1.53	22.00	0.75	12.30
DCR 50-10	600 (67.8)	Part Turn	5.6 seconds/90°	50% (1)	50% (1)	0.90	5.60	0.5	2.10
DCR 50-30	700 (79.1)	Part Turn	21 seconds/90°	50% (2)	50% (2)	0.15	2.65	0.06	1.15
DCR 90-5	900 (101.7)	Part Turn	2.2 seconds/90°	50% (1)	50% (1)	1.00	12.50	0.75	6.60
DCR 90-5MT	900 (101.7)	Multi-Turn	7 RPM	50% (2)	50% (2)	1.00	12.50	0.75	6.60
DCR 90-15	900 (101.7)	Part Turn	5.6 seconds/90°	50% (2)	50% (2)	0.90	5.60	0.50	2.10

* (N.L.A.) — No Load Ampere (L.R.A.) — Locked Rotor Ampere (1) — Open/Close Service (2) — Open/Close or Positioning Service

Limit Switches (MAR Models)

Standard: Two-single pole, double throw type (SPDT) with an option for 2 or 4 additional.

Ratings: UL and CSA listed.
15 amp & 1/2 H.P. at 125 or 250 VAC;
1/2 amp at 125 VDC;
1/4 amp at 250 VDC; 5 amp at 120 VAC

Optional: All double pole, double throw type (DPDT).

Ratings: UL and CSA listed.
10 amp at 125/250 VAC (form ZZ);
1/2 H.P. at 125 VDC; 3/4 H.P. at 250 VAC

Limit Switches (DCR Models)

Ratings: Ratings: UL and CSA listed.
MIL-PRF-8805 Qualified Listing
25 amp at 277 VAC; 1 H.P. at 125 VAC;
2 H.P. at 250 VAC

Isolation Relays

To operate multiple actuators in parallel from a single signal requires isolating relays in the actuator or the field wiring.

Duty Cycle

The percentage of time the electric motor is energized vs. the time it is at rest, in reversing duty, and with the actuator running at the rated maximum published torque.

Standard Modulating Duty Rating

12 motor starts (corrections) per minute at the rated duty cycle for that model with the speed of operation a minimum of 15 seconds for 90° or slower with positioning accuracy of (+/-) 1% of total span.

Note — Multi-turn models are available with the following number of turns:

1.4, 5, 8, 13, 18, 26 or 50. This must be specified when the order is placed.

Part-Turn Electric | Multi-Turn Electric



NEMA 4 Enclosure

Approvals

MAR Models Only
(Canadian Standards Association)

CSA NRTL/C Type 4



NEMA 4/4X/6/7 Enclosure

Approvals

MAR Models Only
(Canadian Standards Association)

CSA NRTL/C Type 4/4X and 6

CSA NRTL/C Class I, Division 1,
Groups C & D

CSA NRTL/C Class II, Division 1,
Groups E, F & G

CSA NRTL/C Approved to UL Standard
No. 429, Electrically Operated
Valves

CSA NRTL/C Approved to UL Standard No.
1203, Electrical Equipment for
use in Explosion - proof
And Dust - Ignition - proof
Hazardous (Classified)
Locations

Models	
A.C. Voltages	D.C. Voltages
MAR-100	DCR-100
MAR-120	DCR-160
MAR-160	DCR-250
MAR-250	DCR-800
MAR-800	
Typical Applications	
For open / Close or positioning control of:	
<ul style="list-style-type: none"> ■ Part turn ball, butterfly, choke or plug valves ■ Multi-turn valve types ■ Ventilation dampers ■ Select Multi-turn Valves 	
Temperature Range	
Standard: -40°F to +150°F -40°C to +66°C	
Optional: -60°F to +120°F -51°C to +49°C	
(Note: With heater installed and energized)	
Optional: Compliance to NFPA 130 and NFPA 502, capable of operation after exposure to ambient temperature of 482°F (250°C) for a minimum of 1 hour	
Voltage	
115 VAC, 1 Phase, 50/60 Hz. 230 VAC, 1 Phase, 50/60 Hz. 220 VAC, 3 Phase, 60 Hz. 440 VAC, 3 Phase, 60 Hz. 12 VDC 24 VDC	
Torque Range	
1,500 to 10,000 inch pounds (169.5 to 1129.8 newton meters)	
Speed Range	
For 60 Hz. operation: 1.25 to 60 seconds for 90° revolution 5 to 12 RPM for multi-turns	
Standard Features	
AC (Single and Three Phase) Voltages 4 – SPDT Switches, PTC Heater DC Voltages, 4 – SPDT (High Current) Switches, Handwheel manual override with electrical isolation	

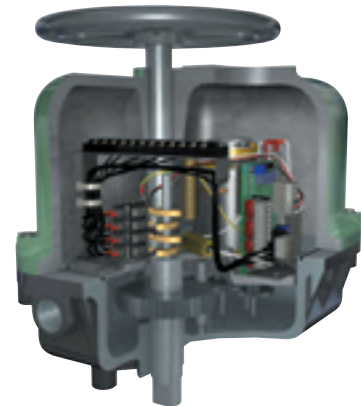
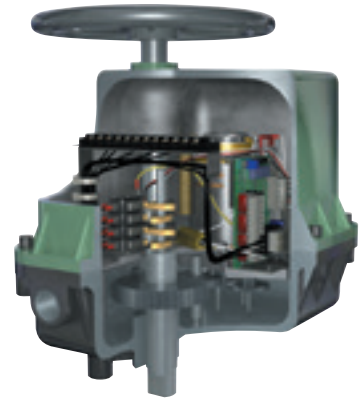

Part-Turn Electric | Multi-Turn Electric

Outline Dimensions (Inches) – MAR & DCR 100, 120, 160 & 250

Weight
NEMA 4/6 Enclosure: 34 lbs/15.45 kg
NEMA 4/4X/6/7 Enclosure: 44 lbs/20 kg

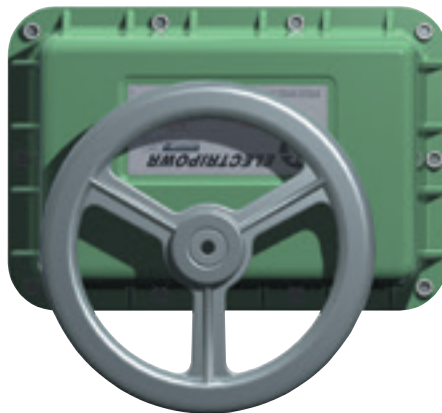
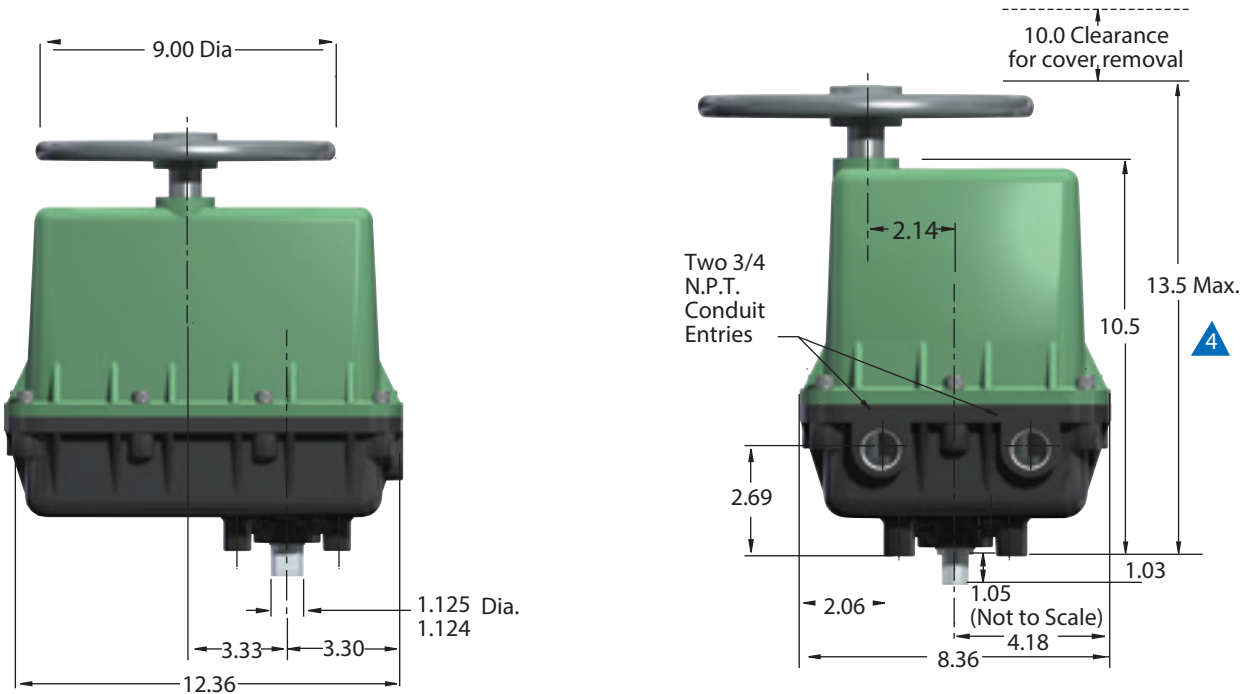

Mounting Geometry

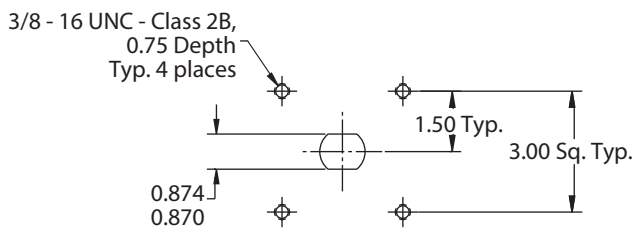

Notes

1. Drawing shows the actuator output shaft in a fully clockwise (closed) position.
2. Direction of actuator rotation is based on the top view from the handwheel.
3. A NEMA 4 control cover is shown. Dimensions given are accurate for NEMA 4/6/7.
4. Actuator is shown with handwheel in electrical mode. Height is 13.0" when manual override is used.

Part-Turn Electric | Multi-Turn Electric

Outline Dimensions (Inches) – MAR & DCR 800

Weight
NEMA 4 Enclosure: 34 lbs/15.4 kg
NEMA 4/6/7 Enclosure: 44 lbs/20 kg

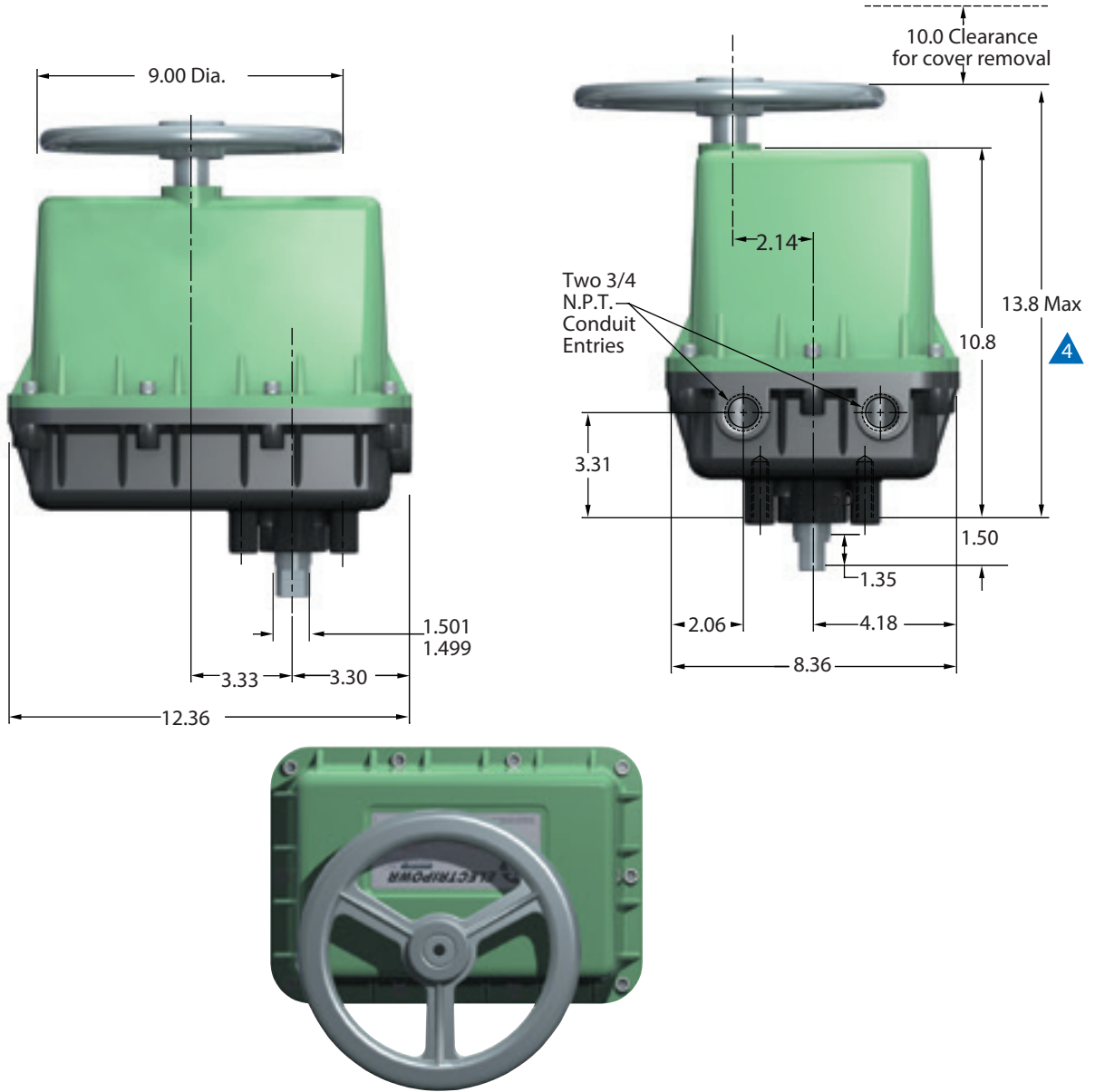

Mounting Geometry

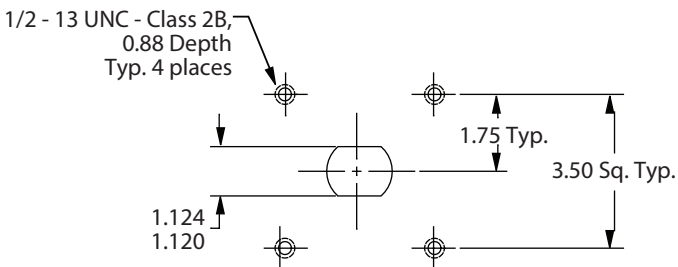

Notes

1. Drawing shows the actuator output shaft in a fully clockwise (closed) position.
2. Direction of actuator rotation is based on the top view from the handwheel.
3. A NEMA 4 control cover is shown. Dimensions given are accurate for NEMA 4/6/7.
4. Actuator is shown with handwheel in electrical mode. Height is 13.3" when manual override is used.

Part-Turn Electric

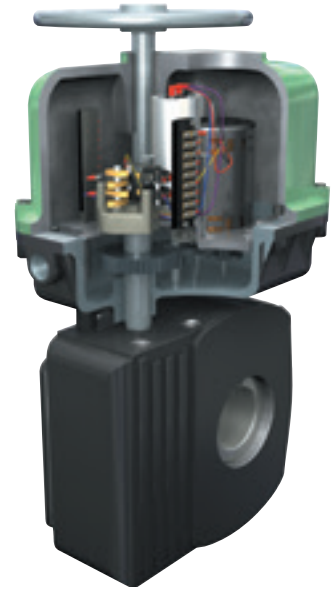

Models
MAR 1600, MAR 4000
Typical Applications
For open / close or positioning control of:
<ul style="list-style-type: none"> ■ Part turn ball, butterfly or plug valves ■ Rotary dampers
Temperature Range
Standard: -40°F +150°F -40°C to +65°C
Optional: -60°F to +150°F -50°C to +65°C
Voltage
115 VAC, 1 Phase, 50/60 Hz. 230 VAC, 1 Phase, 50/60 Hz. 220 VAC, 3 Phase, 60 Hz. 440 VAC, 3 Phase 60 Hz.
Torque Range
21,000 to 48,000 inch pounds (2,373 to 5,424 newton meters)
Speed Range
70 & 160 seconds for 90° revolution
Standard Features
AC (Single or Three Phase) Voltages 4 – SPDT Switches, Thermostatically controlled PTC heater Handwheel manual override with electrical isolation

NEMA 4/6/7 Enclosure

Approvals

A.C. Models (Canadian Standards Association)	
CSA NRTL/C	Type 4 and 6
CSA NRTL/C	Class I, Division 1, Groups C & D
CSA NRTL/C	Class II, Division 1, Groups E, F & G
CSA NRTL/C	Approved to UL Standard No. 429, Electrically Operated Valves
CSA NRTL/C	Approved to UL Standard No. 1203, Electrical Equipment for use in Explosion - proof And Dust - Ignition - proof Hazardous (Classified) Locations

Part-Turn Electric

Outline Dimensions (Inches) – MAR 1600-65 and 4000-160

Weight
NEMA 4/4X/6/7 Enclosure: 126 lbs/57.2 kg

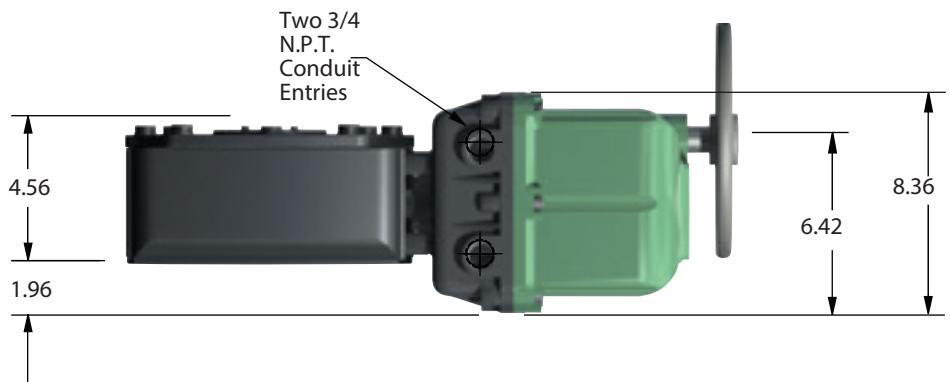
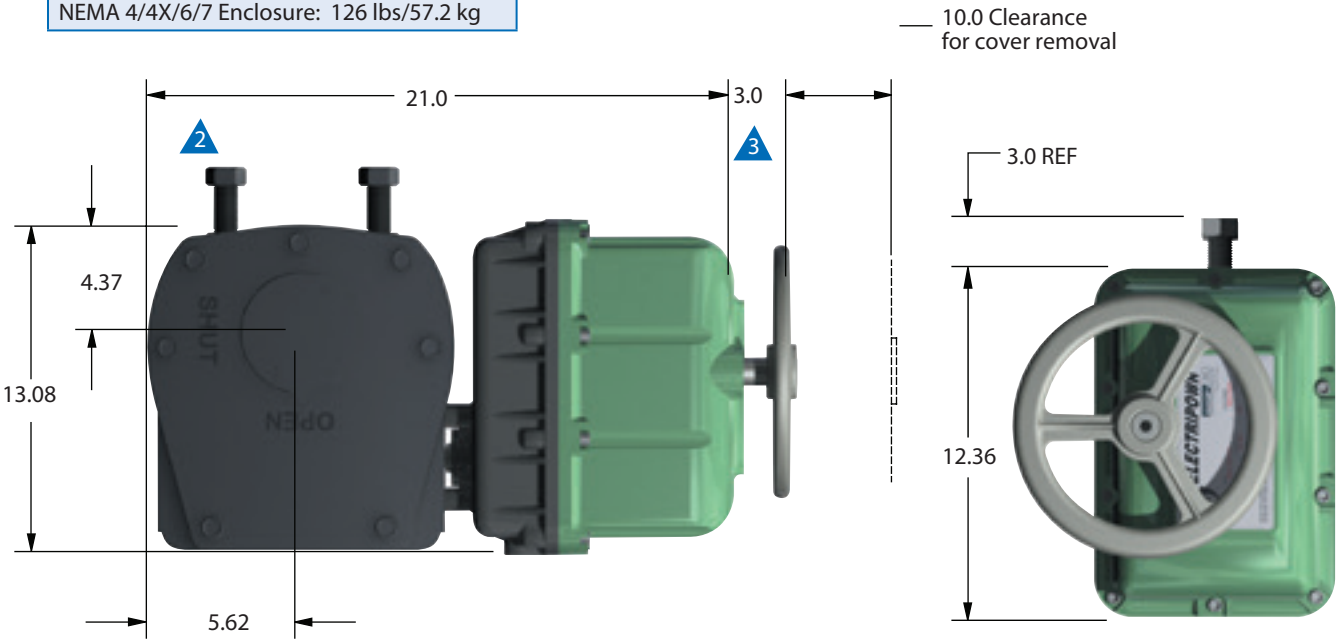

Mounting Geometry

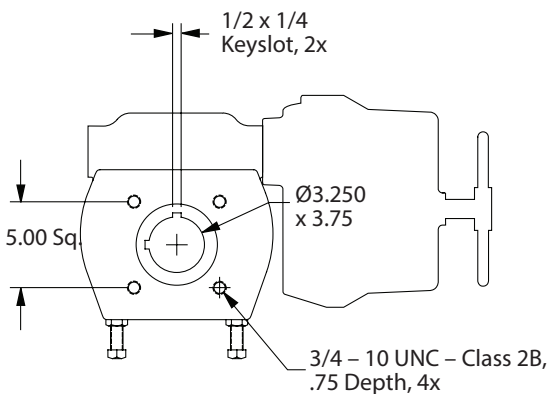

Notes

1. Drawing shows the actuator output shaft in a fully clockwise (closed) position.
2. Direction of actuator rotation is based on the top view of the eternal gearbox.
3. Actuator is shown with handwheel in electrical mode. Height is 2.4" when manual override is used.

Part-Turn Electric | Multi-Turn Electric

115 & 230 VAC, 1 Phase, 50/60 Hz.

Model	Output Torque Inch Pounds (N.m)	Type	Speed of Operation 60 Hz. (50 Hz.)	Duty Cycle Rating 115 Vac, 1Ph., 50/60 Hz.	Duty Cycle Rating 230 Vac, 1Ph., 50/60 Hz.	Current Ratings 115 VAC		Current Ratings 230 VAC	
						NLA*	LRA*	NLA*	LRA*
MAR 100-16	1,500 (169)	Part Turn	16 seconds/90° (19 seconds/90°)	100% (2)	50% (2)	0.55	1.55	0.25	0.85
MAR 100-30	1,800 (203)	Part Turn	30 seconds/90° (35 seconds/90°)	100% (2)	50% (2)	0.50	0.60	0.30	0.35
MAR 100-60	2500 (282)	Part Turn	60 seconds/90° (70 seconds/90°)	100% (2)	50% (2)	0.35	0.55	0.20	0.35
MAR 120-1.25	1,500 (169)	Part Turn	1.25 seconds/90° (2 seconds/90°)	25% (1)	25% (1)	3.30	7.40	1.30	3.60
MAR 120-1.25 MT	1,500 (169)	Multi-Turn	12 RPM (10 RPM)	25% (2)	25% (2)	3.30	7.40	1.30	3.60
MAR 160-8	1,920 (217)	Part Turn	8 seconds/90° (9 seconds/90°)	50% (1)	50% (1)	0.75	1.65	0.70	1.05
MAR 160-16	2,000 (226)	Part Turn	16 seconds/90° (19 seconds/90°)	75% (2)	50% (2)	0.60	1.60	0.35	0.90
MAR 160-30	2,500 (282)	Part Turn	30 seconds/90° (35 seconds/90°)	75% (2)	50% (2)	0.65	0.70	0.45	0.50
MAR 160-60	2,800 (316)	Part Turn	60 seconds/90° (70 seconds/90°)	100% (2)	50% (2)	0.50	0.60	0.30	0.35
MAR 250-3	3,500 (395)	Part Turn	3 seconds/90° (4 seconds/90°)	25% (1)	50% (1)	3.30	7.40	0.90	3.40
MAR 250-3MT	3,500 (395)	Multi-Turn	5 RPM (4 RPM)	25% (2)	50% (2)	3.30	7.40	0.90	3.40
MAR 250-8	3,000 (339)	Part Turn	8 seconds/90° (9 seconds/90°)	40% (1)	50% (1)	1.60	2.20	1.00	1.25
MAR 250-16	4,000 (452)	Part Turn	16 seconds/90° (19 seconds/90°)	50% (2)	50% (2)	1.10	1.80	0.70	1.05
MAR 250-30	5,000 (565)	Part Turn	30 seconds/90° (35 seconds/90°)	50% (2)	50% (2)	0.75	1.65	0.50	0.95
MAR 250-60	5,000 (565)	Part Turn	60 seconds/90° (70 seconds/90°)	75% (2)	50% (2)	0.65	0.70	0.30	0.35
MAR 800-12	7,500 (847)	Part Turn	12 seconds/90° (14 seconds/90°)	25% (1)	25% (1)	3.30	7.40	0.90	3.40
MAR8 00-30	10,000 (1,130)	Part Turn	30 seconds/90° (35 seconds/90°)	40% (2)	50% (2)	1.60	2.20	1.00	1.20
MAR 800-60	10,000 (1,130)	Part Turn	60 seconds/90° (70 seconds/90°)	75% (2)	50% (2)	0.55	1.55	0.50	0.95
MAR 1600-70	21,000 (2,373)	Part Turn	70 seconds/90° (82 seconds/90°)	25% (2)	50% (2)	3.30	7.40	0.90	3.40
MAR 4000-160	48,000 (5,424)	Part Turn	170 seconds/90° (200 seconds/90°)	25% (2)	50% (2)	3.30	7.40	0.90	3.40

* (N.L.A.) — No Load Ampere (L.R.A.) — Locked Rotor Ampere (1) — Open/Close Service (2) — Open/Close or Positioning Service

Duty Cycle

The percentage of time the electric motor is energized vs. the time it is at rest, in reversing duty, and with the actuator running at it's rated load maximum published torque.

Standard Modulating Duty Rating

12 motor starts (corrections) per minute at the rated duty cycle for that model with the speed of operation a minimum of 15 seconds for 90° or slower. With positioning accuracy of (+/-) 1% of total span

Isolation Relays

To operate multiple actuators in parallel from a single signal requires isolating relays in the actuator or the field wiring.

Note — Multi-turn models are available with the following number of turns: 1.4, 5, 8, 13, 18, 26 or 50. Must be specified when the order is placed.

Part-Turn Electric | Multi-Turn Electric

12 & 24 VDC

Model	Output Torque Inch Pounds (N.m)	Type	No Load Speed of Operation	Duty Cycle Rating 12 VDC	Duty Cycle Rating 24 VDC	Current Ratings 12 VDC		Current Ratings 24 VDC	
						NLA*	LRA*	NLA*	LRA*
DCR 100-30	2,000 (225)	Part Turn	11.5 seconds/90°	50% (2)	50% (2)	0.90	5.80	0.50	2.10
DCR 160-16	2,200 (248)	Part Turn	5.5 seconds/90°	50% (1)	50% (1)	1.00	12.50	0.75	6.80
DCR 160-60	3,600 (406)	Part Turn	22 seconds/90°	50% (2)	50% (2)	0.90	5.80	0.50	2.10
DCR 250-8	3,000 (339)	Part Turn	3.2 seconds/90°	50% (1)	50% (1)	1.53	22.00	0.75	12.00
DCR 250-16	4,000 (452)	Part Turn	5.7 seconds/90°	50% (1)	50% (1)	1.53	22.00	0.75	12.00
DCR 250-30	5,000 (565)	Part Turn	11.2 seconds/90°	50% (2)	50% (2)	1.00	12.50	0.75	6.60
DCR 800-30	10,000 (1,130)	Part Turn	13.3 seconds/90°	50% (2)	50% (2)	1.53	22.00	0.75	12.30
DCR 800-60	10,000 (1,130)	Part Turn	23 seconds/90°	50% (2)	50% (2)	1.00	12.50	0.75	6.60

* (N.L.A.) — No Load Ampere (L.R.A.) — Locked Rotor Ampere (1) — Open/Close Service (2) — Open/Close or Positioning Service

Limit Switches (MAR Models)

Standard: Four-single pole, double throw type (SPDT) with an option for 2 additional.

Ratings: UL and CSA listed.

15 amp & 1/2 H.P. at 125 or 250 VAC

1/2 amp at 125 VDC;

1/4 amp at 250 VDC

Lamp Load: 5 amp at 120 VAC

Optional: All double pole, double throw type (DPDT).

Ratings: UL and CSA listed.

10 amp at 125/250 VAC (form ZZ);

1/2 H.P. at 125 VDC; 3/4 H.P. at

250 VAC

Limit Switches (DCR Models)

Ratings: Ratings: UL and CSA listed.

MIL-PRF-8805 Qualified Listing

25 amp at 277 VAC; 1 H.P. at 125 VAC;

2 H.P. at 250 VAC

Isolation Relays

To operate multiple actuators in parallel from a single signal requires isolating relays in the actuator or the field wiring.

Heater

Thermostatically controlled PTC heater is standard in all AC voltage models.

Part-Turn Electric | Multi-Turn Electric

220 & 440 VAC, 3 Phase, 60 Hz.

Model	Output Torque Inch Pounds (N.m)	Type	Speed of Operation 60 Hz. (50 Hz.)	Duty Cycle Rating 230 Vac, 3Ph., 60 Hz.	Duty Cycle Rating 460 Vac, 3Ph., 60 Hz.	Current Ratings 220 VAC		Current Ratings 440 VAC	
						NLA*	LRA*	NLA*	LRA*
MAR 100-16	1,500 (169)	Part Turn	16 seconds/90° (19 seconds/90°)	25%	25%	0.34	1.20	0.15	0.75
MAR 120-1.25	1,500 (169)	Part Turn	1.25 seconds/90° (2 seconds/90°)	25%	25%	1.60	3.50	0.82	1.80
MAR 120-1.25 MT	1,500 (169)	Multi-Turn	12 RPM (10 RPM)	25%	25%	1.60	3.50	0.82	1.80
MAR 160-8	1,920 (217)	Part Turn	8 seconds/90° (9 seconds/90°)	25%	25%	0.34	1.20	0.15	0.75
MAR 160-16	2,000 (226)	Part Turn	16 seconds/90° (19 seconds/90°)	25%	25%	0.34	1.20	0.15	0.75
MAR 250-3	3,500 (316)	Part Turn	3 seconds/90° (4 seconds/90°)	25%	25%	1.60	3.50	0.82	1.80
MAR 250-3MT	3,500 (316)	Multi-Turn	5 RPM (4 RPM)	25%	25%	1.60	3.50	0.82	1.80
MAR 250-16	4,000 (452)	Part Turn	16 seconds/90° (19 seconds/90°)	25%	25%	0.34	1.20	0.15	0.75
MAR 250-30	5,000 (565)	Part Turn	30 seconds/90° (35 seconds/90°)	25%	25%	0.34	1.20	0.15	0.75
MAR 250-60	5,000 (565)	Part Turn	60 seconds/90° (70 seconds/90°)	25%	25%	0.34	1.20	0.15	0.75
MAR 800-12	7,500 (847)	Part Turn	12 seconds/90° (14 seconds/90°)	25%	25%	1.60	3.50	0.82	1.80
MAR 800-30	10,000 (1,130)	Part Turn	30 seconds/90° (35 seconds/90°)	25%	25%	0.34	1.20	0.15	0.75
MAR 800-60	10,000 (1,130)	Part Turn	60 seconds/90° (70 seconds/90°)	25%	25%	0.34	1.20	0.15	0.75
MAR 1600-70	21,000 (2,373)	Part Turn	70 seconds/90° (80 seconds/90°)	25%	25%	1.60	3.50	0.82	1.80
MAR 4000-160	48,000 (5,424)	Part Turn	170 seconds/90° (200 seconds/90°)	25%	25%	1.60	3.50	0.82	1.80

* (N.L.A.) — No Load Ampere (L.R.A.) — Locked Rotor Ampere (1) — Open/Close Service (2) — Open/Close or Positioning Service

Isolation Relays

To operate multiple actuators in parallel from a single signal requires isolating relays in the actuator or the field wiring.

Duty Cycle

The percentage of time the electric motor is energized vs. the time it is at rest, in reversing duty, and with the actuator running at it's rated load maximum published torque.

Standard Modulating Duty Rating

12 motor starts (corrections) per minute at the rated duty cycle for that model with the speed of operation a minimum of 15 seconds for 90° or slower with positioning accuracy of (+/-) 1% of total span.

Note — Multi-turn models are available with the following number of turns: 1.4, 5, 8, 13, 18, 26 or 50. Must be specified when the order is placed.

Spring Return Electric

Optional Manual Override Available



NEMA 4 Enclosure

A.C. Models Only
(Canadian Standards Association)

CSA NRTL/C Type 4



NEMA 7 Enclosure

A.C. Models Only
(Canadian Standards Association)

CSA NRTL/C Class I, Division 1,
Groups C & D

CSA NRTL/C Class II, Division 1,
Groups E, F, & G

CSA NRTL/C Approved to UL Standard
No. 429, Electrically Operated
Valves

CSA NRTL/C Approved to UL Standard No.
1203, Electrical Equipment
for use in Explosion - proof
And Dust - Ignition - proof
Hazardous (Classified)
Locations

Models

SURE 24, SURE 25

Typical Applications

For For open / close and positioning control of:

- Quarter-turn ball, butterfly, plug valves or rotary dampers when emergency shutdown or shutoff capability is required in the event of a loss of power.

Temperature Range

Standard: -40°F to +150°F
-40°C to +65°C

Optional: -60°F to +150°F
-50°C to +65°C

Optional: Compliance to NFPA 130 and NFPA 502, capable of operation after exposure to ambient temperature of 482°F (250°C) for a minimum of 1 hour

Voltage

115 VAC, 1 Phase, 50/60 Hz.
230 VAC, 1 Phase, 50/60 Hz.

Torque Range

300 pound inches spring end (34 newton meters)

Speed Range

5 & 10 seconds for 90° revolution, motor operation
2 to 5 seconds spring operation

Spring

Flat, spring steel torsion spring, XYLAN® coated

Standard Features

AC Voltages
2 – SPDT Switches,
Thermostatically controlled
PTC heater, Motor Brake

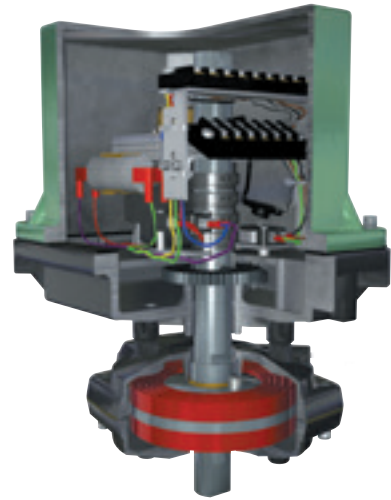

SURE 24

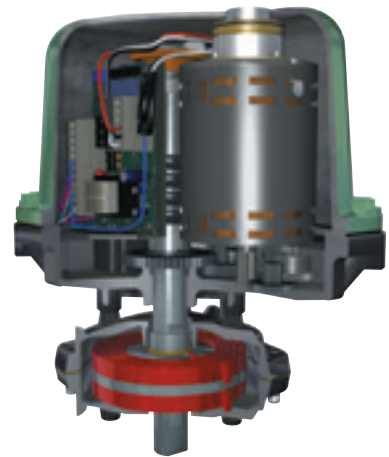

SURE 25

Spring Return Electric

Outline Dimensions (Inches) – SURE 24/25

Weight
23 lbs/10.4 kg

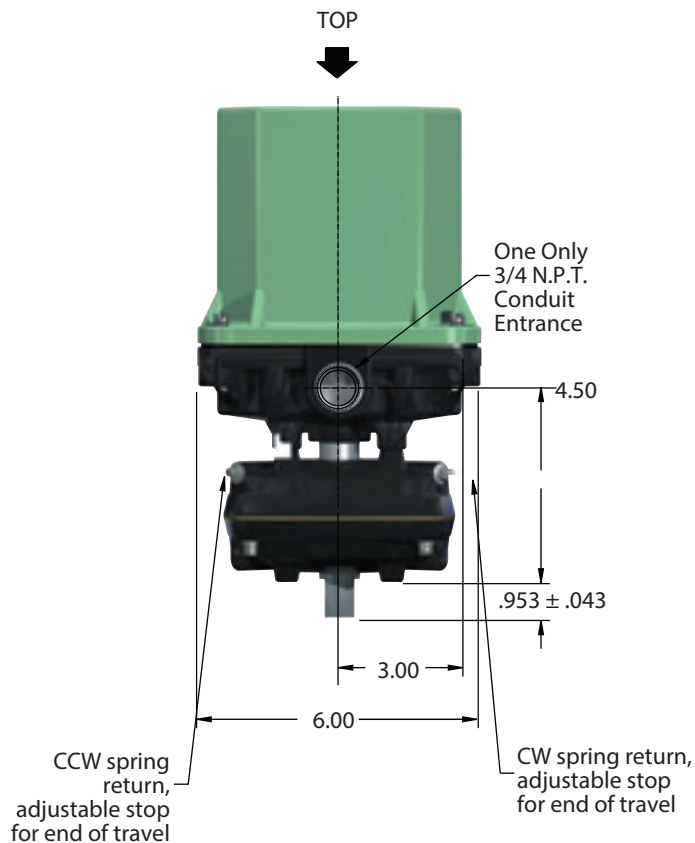
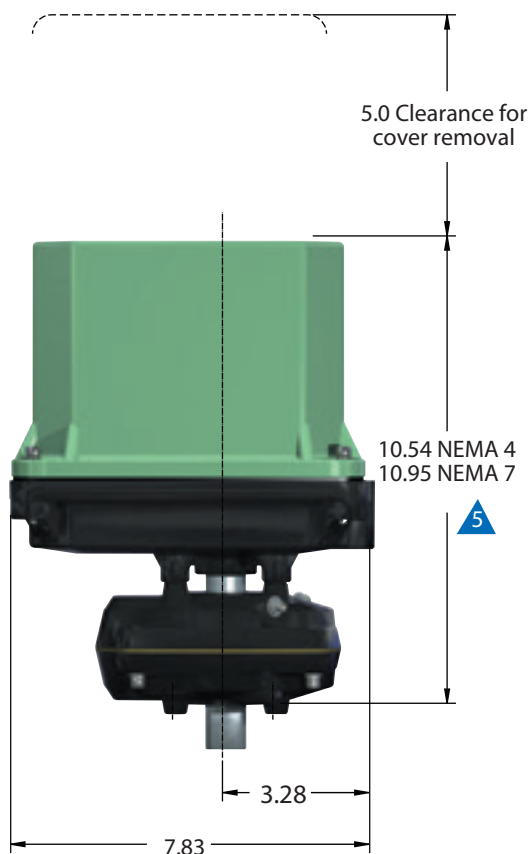

Mounting Geometry - Bottom View

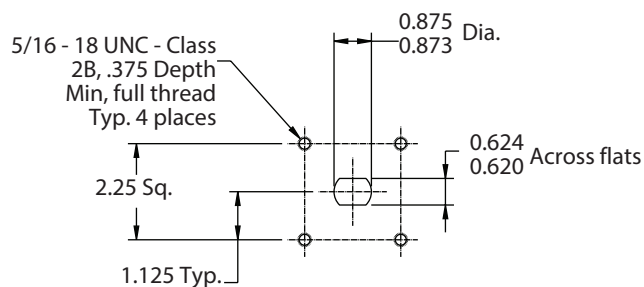

Notes

1. Direction of rotation is based on viewing actuator from top.
2. Drawing shows actuator output shaft in power fail clockwise position.
3. Standard unit fails clockwise (closed).
4. Optional unit fails counter-clockwise (open).
5. NEMA 4 cover shown.
Dimensions given are accurate for NEMA 7.

Spring-Return Electric Actuator



Models
SURE 65
Typical Applications
For open / close and positioning control of: <ul style="list-style-type: none"> Quarter-turn ball, butterfly, plug valves or rotary dampers when emergency shutdown or shutoff capability is required in the event of a loss of power
Temperature Range
Standard: -40°F to +150°F -40°C to +65°C
Optional: -60°F to +150°F -50°C to +65°C
Optional: Compliance to NFPA 130 and NFPA 502, capable of operation after exposure to ambient temperature of 482°F (250°C) for a minimum of 1 hour
Voltage
115 VAC, 1 Phase, 50/60 Hz. 230 VAC, 1 Phase, 50/60 Hz.
Torque Range
780 pound inches spring end (84 newton meters)
Speed Range
10 and 30 seconds for 90° revolution, motor operation 3 seconds spring operation
Spring
Spring steel, EVERLUBE® 620C coated
Standard Features
AC Voltages 4 – SPDT Switches, Thermostatically controlled PTC heater, Motor Brake

NEMA 4/6/7 Enclosure

Approvals

A.C. Models Only

(Canadian Standards Association)

CSA NRTL/C Type 4 and 6

CSA NRTL/C Class I, Division 1 & 2, Groups C & D

CSA NRTL/C Class II, Division 1, Groups E, F & G

CSA NRTL/C Approved to UL Standard No. 429, Electrically Operated Valves

CSA NRTL/C Approved to UL Standard No. 1203, Electrical Equipment for use in Explosion - proof And Dust - Ignition - proof Hazardous (Classified) Locations

ATEX - Ex db IIB T5 Gb; Explosive gas atmosphere / Flameproof enclosure / Gas group IIB / Temperature code T5 / Zone

(Pending) Ex tb IIIC T85°C Db; Explosive dust atmosphere / dust tight enclosure / Dust group IIIC / Temp code T85°C / Zone 21

Ambient temperature range: -20°C to +65°C (-4°F to +150°F)

CE Certified

Spring-Return Electric Actuator

Outline Dimensions (Inches) – SURE 65

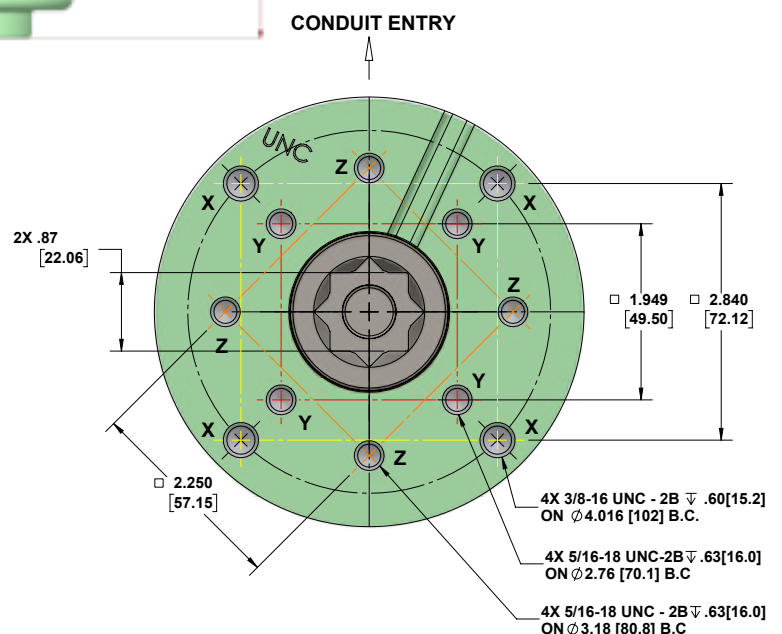
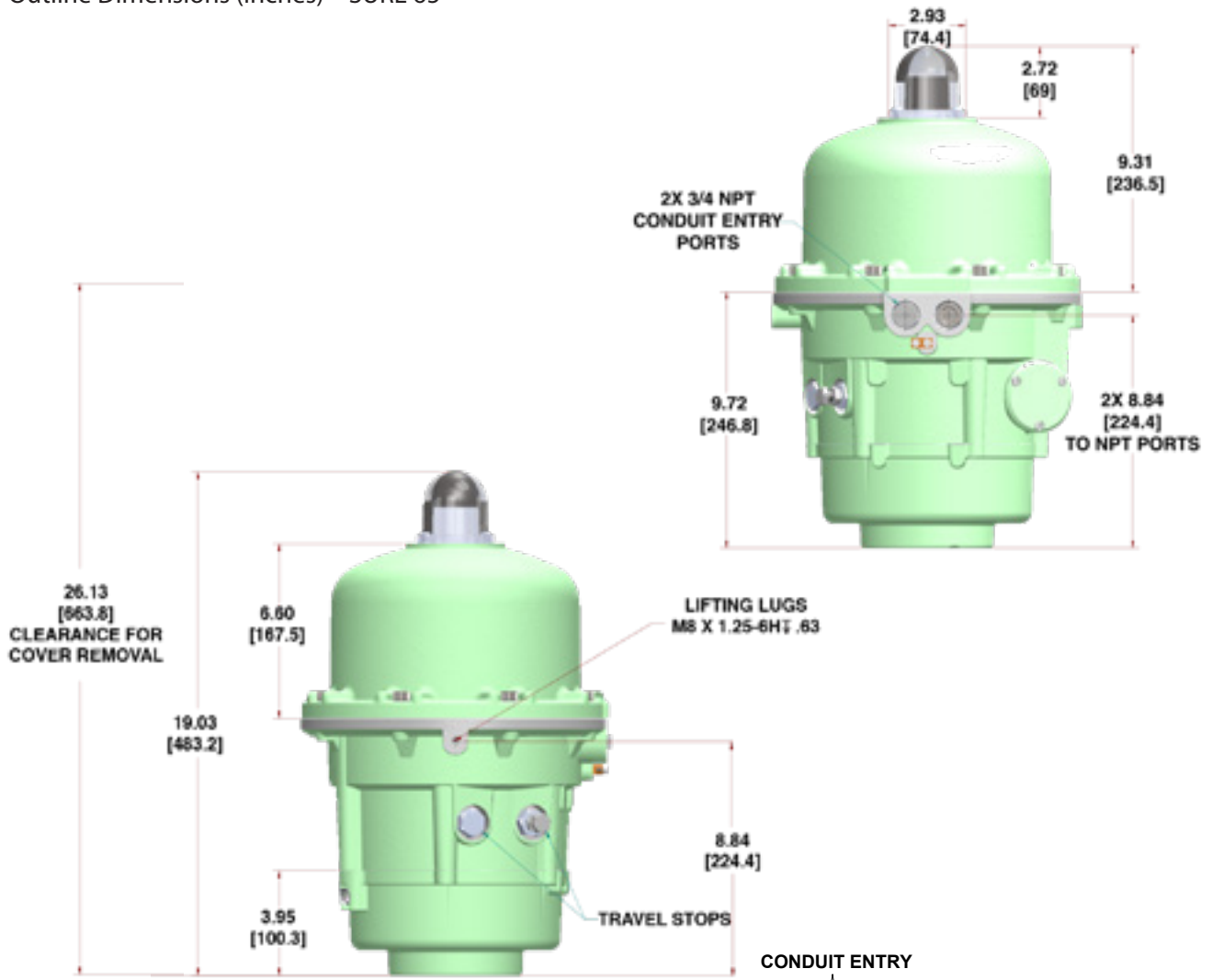

SURE 65 OUTPUT DRIVE F10
INCH[MM]
HOLES MARKED "X" FOR F10 MOUNT
HOLES MARKED "Y" FOR F07 MOUNT
HOLES MARKED "Z" FOR SURE 49 MOUNTING

Spring Return Electric

Optional Manual Override Available



NEMA 4/6/7 Enclosure

Approvals

A.C. Models Only (Canadian Standards Association)	
CSA NRTL/C	Type 4/4X/6
CSA NRTL/C	Class I, Division 1, Groups C & D
CSA NRTL/C	Class II, Division 1, Groups E, F & G
CSA NRTL/C	Approved to UL Standard No. 429, Electrically Operated Valves
CSA NRTL/C	Approved to UL Standard No. 1203, Electrical Equipment for use in Explosion - proof And Dust - Ignition - proof Hazardous (Classified) Locations
ATEX	Ex db IIB T5 Gb; Explosive gas atmosphere / Flameproof enclosure / Gas group IIB / Temperature code T5 / Zone 1 Ex tb IIIC T85°C Db; Explosive dust atmosphere / dust tight enclosure / Dust group IIIC / Temp code T85°C / Zone 21 Ambient temperature range: -20°C to +65°C (-4°F to +150°F) CE Certified

Models
SURE 100
Typical Applications
For open / close and positioning control of: <ul style="list-style-type: none"> Quarter-turn ball, butterfly, plug valves or rotary dampers when emergency shutdown or shutoff capability is required in the event of a loss of power
Temperature Range
Standard: -40°F to +150°F -40°C to +65°C
Optional: -60°F to +150°F -50°C to +65°C
Optional: Compliance to NFPA 130 and NFPA 502, capable of operation after exposure to ambient temperature of 482°F (250°C) for a minimum of 1 hour
Voltage
115 VAC, 1 Phase, 50/60 Hz. 230 VAC, 1 Phase, 50/60 Hz.
Torque Range
1200 pound inches spring end (136 newton meters)
Speed Range
10 & 30 seconds for 90° revolution, motor operation 5 to 7 seconds spring operation
Spring
Helical torsion spring, spring steel, XYLAN [®] coated
Standard Features
AC Voltages 4 – SPDT Switches, Thermostatically controlled PTC heater, Motor Brake



Spring Return Electric

Outline Dimensions (Inches) – SURE 100

Weight
NEMA 4/4X/6/7 Enclosure: 77 lbs/35 kg

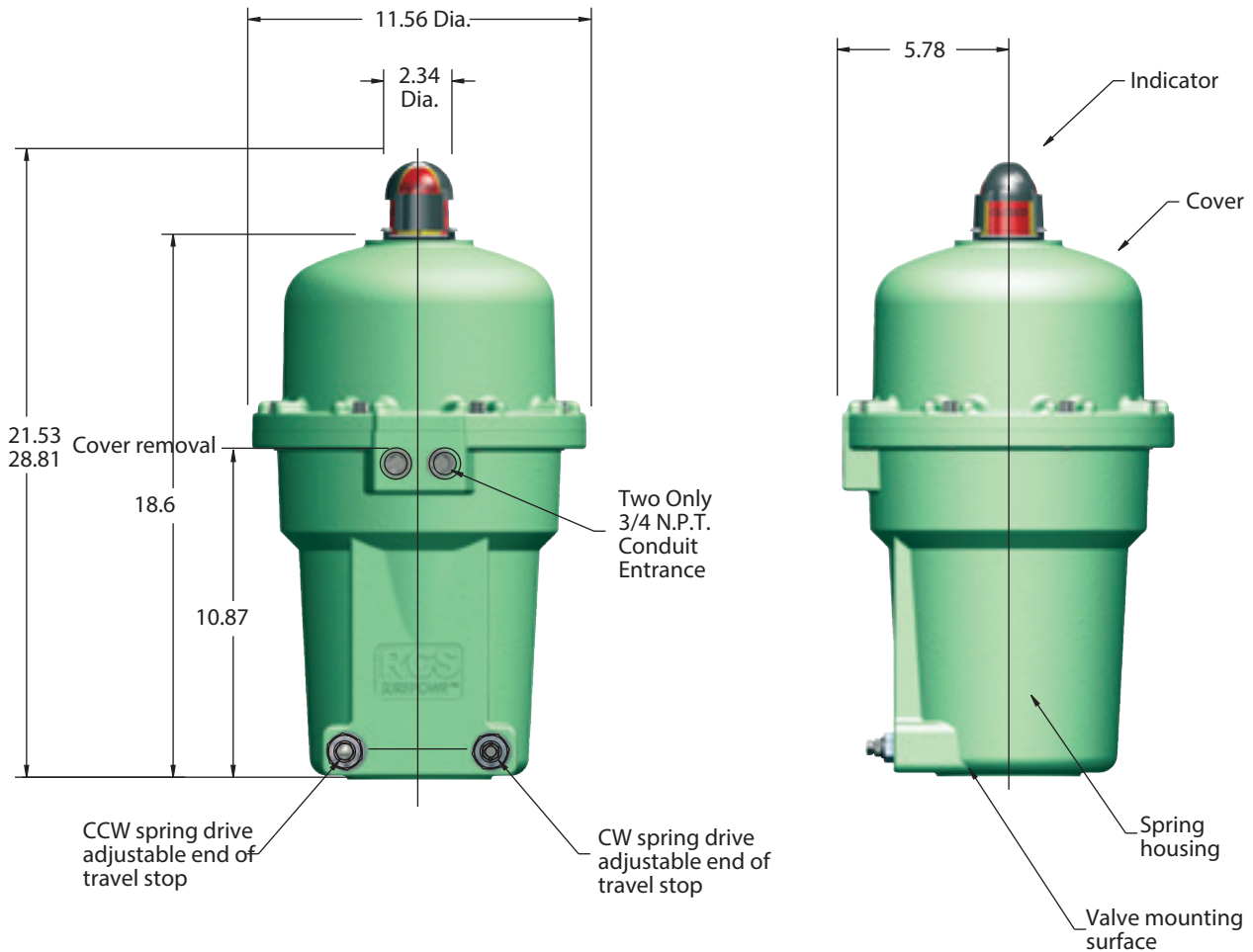

Conduit Entries

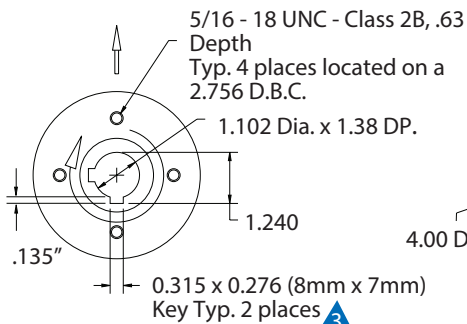

CCW Spring Return

Conduit Entries

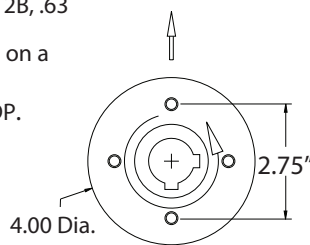

CW Spring Return

Notes

1. Direction of rotation is based on viewing actuator from top.
2. Actuator shown in a power fail position.
- 3.** Two keys are recommended for driving device.
4. It is recommended that the actuator be driven electrically in both directions for normal operation and prolonged life.

Spring Return Electric

Optional Manual Override Available



NEMA 4/6/7 Enclosure

Approvals

CSA NRTL/C	Class I, Division 1, Groups C & D
CSA NRTL/C	Class II, Division 1, Groups E, F & G
CSA NRTL/C	Approved to UL Standard No. 1203, CSA C22.2 No. 25-1966, CSA C22.2 No. 30-M1986 Electrical Equipment for use in Explosion-proof and Dust Ignition-proof Hazardous (Classified) Locations
CSA NRTL/C	Approved to UL Standard No. 508, CSA C22.2 No. 14-13, Industrial Control Equipment
ATEX	Ex db IIB T5 Gb; Explosive gas atmosphere / Flameproof enclosure / Gas group IIB / Temperature code T5 / Zone 1 Ex tb IIIC T85°C Db; Explosive dust atmosphere / dust tight enclosure / Dust group IIIC / Temp code T85°C / Zone 21 Ambient temperature range: -20°C to +65°C (-4°F to +150°F) CE Certified

Models	SURE 150
Typical Applications	For open / close and positioning: <ul style="list-style-type: none"> Quarter-turn or rotary movement when emergency shutdown or shutoff capability is required in the event of a loss of power
Temperature Range	Standard: -40°F to +150°F -40°C to +65°C Optional: Compliance to NFPA 130 and NFPA 502, capable of operation after exposure to ambient temperature of 482°F (250°C) for a minimum of 1 hour
Voltage	115 VAC, 1 Phase, 50/60 Hz. 230 VAC, 1 Phase, 50/60 Hz.
Torque Range	1800 pound inches spring end (204 newton meters)
Speed Range	15 seconds for 90° revolution, motor operation 5 seconds spring operation
Spring	Helical torsion spring, spring steel, XYLAN® coated
Standard Features	AC Voltages 4 – SPDT Switches, Thermostatically controlled PTC heater, Motor Brake



Spring Return Electric

Outline Dimensions (Inches) – SURE 150

Weight
120 lbs/54.5 kg

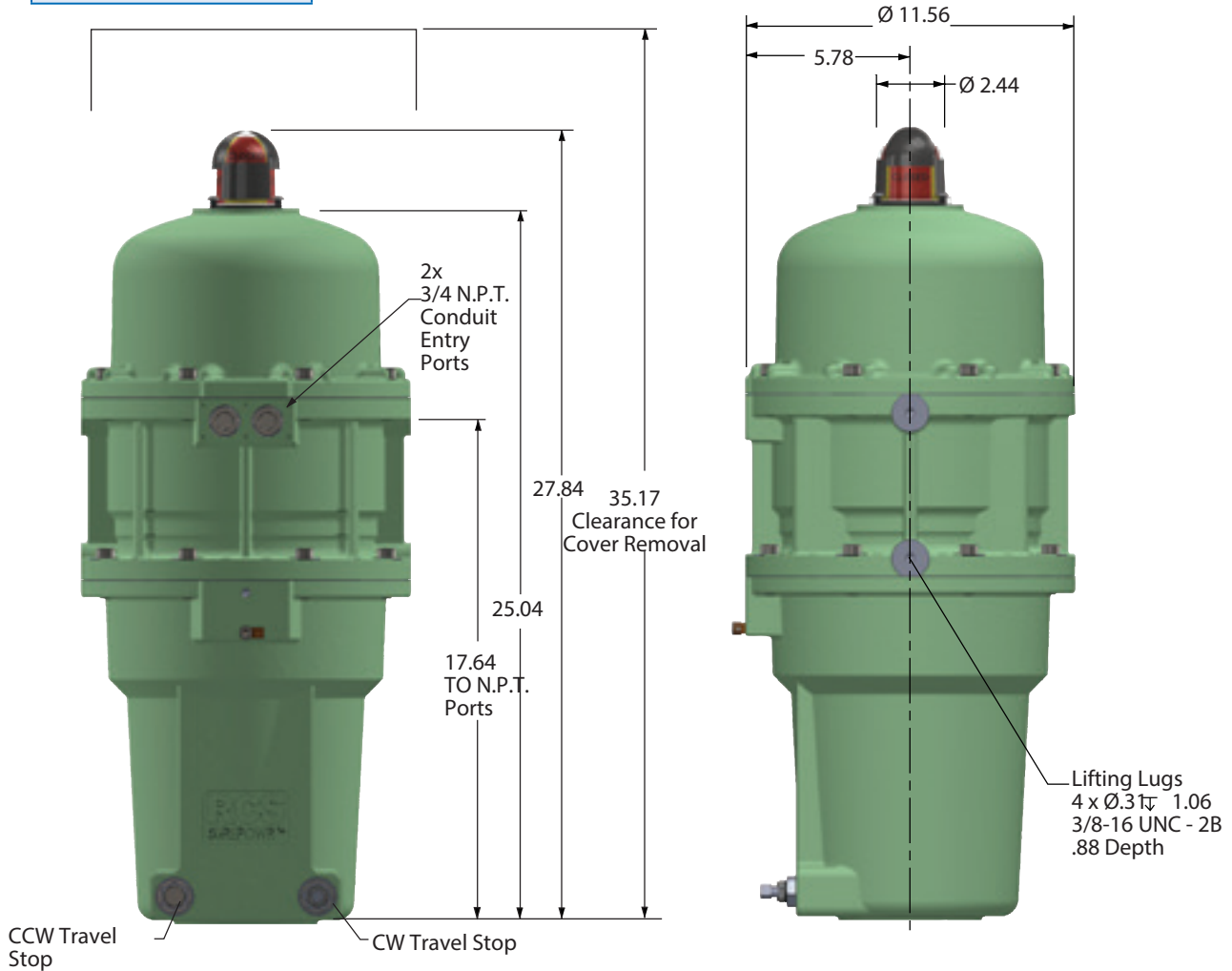

Conduit Entries

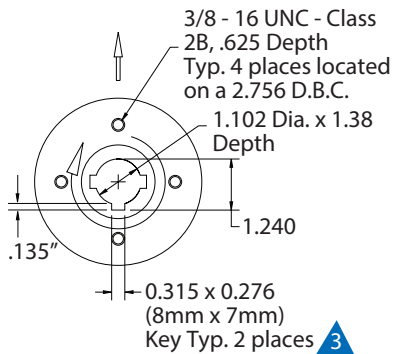

CCW Spring Return

Conduit Entries

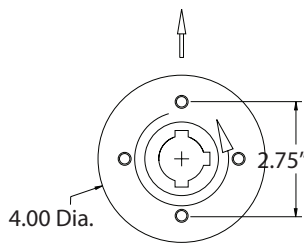

CW Spring Return

Notes

1. Direction of rotation is based on viewing actuator from top.
2. Actuator shown in a power fail position.
3. Two keys are recommended for driving device.
4. It is recommended that the actuator be driven electrically in both directions for normal operation and prolonged life.

Spring Return Electric

115 & 230 VAC, 1 Phase, 50/60 Hz.

Model	Output Torque Inch Pounds (N.m)	Electrical Speed of Operation 60 Hz. (50 Hz.)	Speed of Operation 60 Hz. (50 Hz.)	Duty Cycle Rating 115 VAC	Duty Cycle Rating 230 VAC	Current Ratings 115 VAC		Current Rat- ings 230 VAC	
						NLA*	LRA*	NLA*	LRA*
Sure 25-5	300 (34)	5 seconds/90° (6 seconds/90°)	2 seconds/90°	50% (1)	50% (1)	1.40	2.15	CF**	CF**
Sure 25-10	300 (34)	10 seconds/90° (12 seconds/90°)	2 seconds/90°	50% (2)	50% (2)	1.00	1.55	CF**	CF**
Sure 24-10	300 (34)	10 seconds/90° (12 seconds/90°)	2 seconds/90°	25% (1)	25% (1)	0.70	1.05	0.45	.065
Sure 65-10	780 (88)	10 seconds	3 seconds	45% (1)	45% (1)	1.10	1.90	0.80	0.98
Sure 65-30	780 (88)	30 seconds	7 seconds	75% (2)	75% (2)	0.52	0.89	0.52	0.89
Sure 100-10	1,200 (136)	10 seconds/90° (12 seconds/90°)	5 seconds/90° (max) +	25% (1)	25% (1)	1.90	2.90	0.90	1.35
Sure 100-30	1,200 (136)	30 seconds/90° (35 seconds/90°)	7 seconds/90° (max) +	50% (2)	50% (2)	0.65	0.95	0.35	0.45
Sure 150-15	1,800 (136)	15 seconds/90° (18 seconds/90°)	5 seconds/90° (max) +	25% (1), (2)	25% (1), (2)	1.90	2.90	0.90	1.35

* (N.L.A.) — No Load Ampere
** (CF) — Consult Factory

(L.R.A.) — Locked Rotor Ampere
+ — Approximate, Based on Load

(1) — Open/Close Service

(2) — Open/Close or Positioning Service

Limit Switches (Sure 24 & 25)

Standard: Two-single pole, double throw type (SPDT) with an option for 2 or 4 additional.

Ratings: Ratings: UL and CSA listed.
15 amp & 1/2 H.P. at 125 or 250 VAC
1/2 amp at 125 VDC; 1/4 amp at 250 VDC
Lamp Load: 5 amp at 120 VAC

Isolation Relays

To operate multiple actuators in parallel from a single signal requires isolating relays in the actuator or the field wiring.

Limit Switches (Sure 65, 100, and 150)

Standard: Four-single pole, double throw type (SPDT) with an option for 2 additional.

Ratings: Ratings: UL and CSA listed.
15 amp & 1/2 H.P. at 125 or 250 VAC
1/2 amp at 125 VDC; 1/4 amp at 250 VDC
Lamp Load: 5 amp at 120 VAC

Optional: All double pole, double throw type (DPDT).

Ratings: Ratings: UL and CSA listed.
10 amp at 125 or 250 VAC (form ZZ)
1/2 H.P. at 125 VDC; 3/4 H.P. at 250 VDC

Heater

Thermostatically controlled PTC heater is standard in all AC voltage models.

Duty Cycle

The percentage of time the electric motor is energized vs. the time it is at rest, in reversing duty, and with the actuator running at it's rated load - maximum published torque.

Standard Positioning Duty Rating

12 motor starts (corrections) per minute at the rated duty cycle for that model with the speed of operation a minimum of 15 seconds for 90° or slower with positioning accuracy of (+/-) 1% of total span.

D.C. Analog - ACT-100 Module



Models

ACT-100 - 115/230V
115 or 220 Volt A.C. Actuators

Application

The ACT-100 module provides accurate positioning control of electric motor actuators using an analog input signal. Setup and calibration is greatly simplified using microprocessor based technology. With no dip switches to set or trim pots to adjust, setup is quick and easy using the ACT menu viewable on an LED display. No external meters are required, even for potentiometer setup. Once initial menu settings are chosen, the ACT-100 performs a self-calibration routine, applying the menu selections to actual actuator performance. Calibration values are then stored in permanent non-volatile memory.

Features

Mounts internally in all RCS actuator models: MAR-10, MAR-50, MAR-90, MAR-100, MAR-160, MAR-250, MAR-800 & all SurePowr models.

- Onboard LED display facilitates setup and calibration using the ACT-100 Menu Setup process
- Menu selection selection of input/output ranges including 4-20 mA_{dc}, 1-5 V_{dc}, 2-10 V_{dc}, and 0-10 V_{dc}, or virtually any custom range required
- Automatic calibration feature: no resistors to add, no jumpers, trim pots, or dip switches to configure. Calibration is as simple as the push of a button.
- Menu selectable fail options
- Intelligent positioning reduces motor cycling, increases motor life and extends the actuator duty
- Optional Modbus RTU remote control over a RS-485 network. Complete access to all controller functions from your factory automation system
- Quick disconnect terminal strips facilitate fast and easy actuator maintenance and troubleshooting
- Always wires the same; no need to determine rotation direction during installation; rotation is selected using the selection menu during calibration mode.

Specifications

Power Requirements

Model ACT 100-115/230A

Single phase, 115 or 230 VAC 50/60 Hz. (Jumper selectable)

Input Command Signal

Menu selectable factory defaults:

- 4-20 mA_{dc}
- 1 -5 V_{dc}
- 2-10 V_{dc}
- 0-10 V_{dc}

Infinite adjustment using ACT menu system

Signal Impedance

Input: 250Ω current, 200KΩ voltage

Output: Maximum load 500 ohms current, 500 ohms voltage

Power Output

Solid state, isolated from the input command signal and rated at:

- 5 amps continuous at 115 VAC
- 5 amps continuous at 230 VAC

All ratings assume the ACT-100 module is mounted on the actuator base plate

Sensitivity

Fully adjustable from 0.5% of total span; factory default set to 1% of total span

Dead Band

Automatically set during the calibration process. factory default is 1% of total span, and additional settings are available using the ACT menu system.

Zero Span Adjustment

Automatically set during calibration and fully open positions and input calibration is automatically adjusted.

Split Range

Settable within the span range using at least 1.5V_{dc} or 3mA of input.

Remote Control

Optional Modbus RTU control of all controller functions over a RS-485 multi-drop network

Ambient Temperature

-40°F (with heater) to +150°F (-40°C to +65°C)

Action on Loss of Command Signal

Factory default:

- Fail in last position (no movement)

Additional settings available at setup:

- Fail open (maximum signal value)
- Fail closed (minimum signal value)
- Fail to a preset position

Size

W - 3.70" (94mm)

H - 4.10" 104.14mm)

D - 1.63" (41.4mm)

Relay Outputs:

Three dry contact outputs:

- Fault indicating loss of power, Fuse failed, command signal loss or failure to move to position in preset time
- End of travel CCW
- End of travel CW
- Contacts are rated for 1 A @ 30 V_{dc}, 0.5A @ 135 VAC resistive.

Profibus D.P.

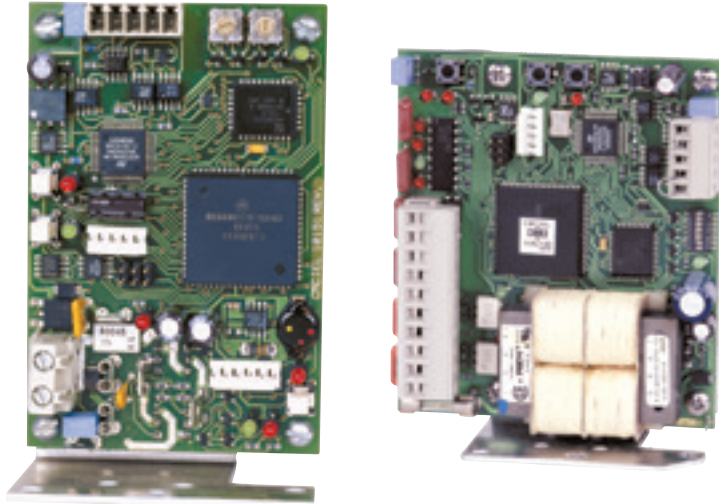

Model
DPC-100 12 or 24 Volt D.C. Actuators

Model
DPC-120 115 Volt A.C. Actuators

Features

- Two wire control reduces installation and start up time compared to multi-cable wiring
- Automatic calibration cuts down on start up time
- No deadband eliminates need for field adjustment.
- On line configuration of 36 operational parameters using generic Profibus software
- Low power consumption; does not require ventilation
- Electronic overload protection with built-in current monitoring
- LED indicators for input, outputs and communication channel
- Automatic calibration with local pushbutton or remote command
- Dynamic breaking eliminates overshooting
- Robust power switching components, designed specifically for actuator motors, virtually eliminates field failures

Specifications

Power Supply

DPC-100: 24/12 VDC

DPC-120: 115 VAC

Communication Interface

Profibus Standard

Protocol

Profibus DP (Distributed Process)

Feedback

Potentiometer 1000 Ohms/Optical Encoder

Position Input Accuracy

1.0% full scale standard, Maximum 0.1%

Temperature

-40°C to +70°C (-40°F to +158°F)

Relative Humidity

0 to 90% non-condensing

Dimensions

DPC-100: 4.0 x 1.5 x 2.5 in.

DPC-120: 4.25 x 1.75 x 3.75 in..

The DPC-100 & DPC-120 provide the following status and fault signals:

Valve full closed

Valve full open

Percentage of open

Valve seeking position

Motor running

Valve closing

Valve opening

Motor thermostat tripped

Incomplete travel

Valve opening or closing manually

Valve jammed/current limiting

Motor still energized after stop or end of travel

Controller self-test (detects problems)

Communication failure

Average running current load

Peak running current load

Idle current load

Devicenet™



Models
DNET115 115 Volt A.C. Actuators

Specifications

Hardware Specifications

Supply Power: 10-15 VDC

Operating Temperature: -40°C TO +90°C

Storage Temperature: -40°C – 80°C

Humidity: 90% Non Condensing

Solid State Outputs: (2) Isolated 600VAC 15A

Digital Inputs: (8) Dry Contacts

Analog Inputs: (2) Channels (see below)

RAM: 1K

Flash: 32K

EEPROM: 32K

Serious Interfaces

One CAN 2.0 port.

Network Communication Protocols

Module Supports DeviceNet™ Group 2 Slave.

Analog Inputs Specification

Resolution: 10 Bit

Accuracy: 1% of FS.

Linearity: 1% of FS.

Temperature Drift: 2% of FS.

Range: 0 to 5V or 0-20mA input for AI1
1-5K Potentiometer for the
Position Feedback.

Technical Summary of DeviceNet™

Network Size: Up to 64 nodes (including scanner)

Network Length: Up to 1,640 ft. at 125 Kbps.

Data Packets: 0-8 bytes

Bus Topology: Trunkline/Dropline

Cable: 5-Conductor cable (2 for power, 2 for communication, and 1 for ground).

Thick Trunk Lines: Belden 3082A or 3083A

Thin Drop Lines: Belden 3084A or 3085A

Drop Lines: Max. drop length is 20 ft. with cumulative drop length of 512 ft.

Repeaters: Not currently, but expected in future revisions of specifications.

Input/Output Listing

Digital Input Status:

Bit 0	Communication Loss
Bit 1	Reserved
Bit 2	Loss of Position Signal
Bit 3	Motor Stall
Bit 4	Limit Calibration Incorrect
Bit 5	Thermostat Trip
Bit 6	Manual Operation
Bit 7-15	Reserved

Digital Output Command:

Bit 0	Open Command
Bit 1	Close Command
Bit 2	Stop Command
Bit 3	ESD Command
Bit 4-7	Future

Application

For on/off or positioning control of motorized valves. DeviceNet™ is a type of communication network that allows up to 63 field devices to be linked together with a single five-conductor cable. DeviceNet™ is a product of Allen-Bradley and is an open, non-proprietary, bus network. Typically, a DeviceNet™ system is used with the Allen-Bradley PLC5 and SLC series of programmable logic controllers. A standard DeviceNet™ Scanner interface is available for both types. Devices in the field are connected via a drop line to a 5 conductor trunk-line that is then routed to the scanner card.

Features

- Provides open/stop/close or positioning control with limit switch status feedback
- Provides instantaneous motor reversal protection
- Command and end-of-travel verification alarm
- Conforms to ODVA standard
- Easy-to-see LED indicators for all control outputs, status inputs and diagnostic alarm
- ESD functions for 'go open', 'stay put', or 'go closed'

Modbus

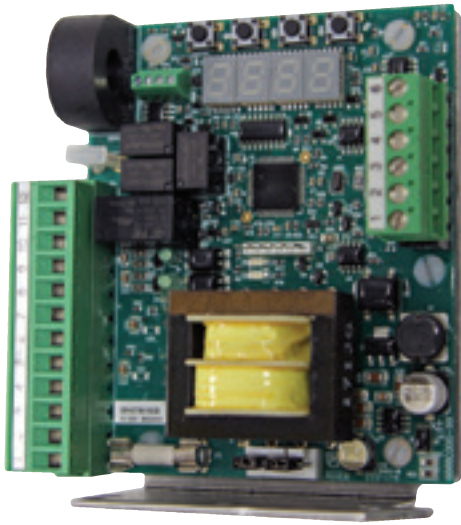

(Above shown with optional current sensing option).

Features

- High resolution position input for up to 0.1% accuracy
- 4-120/240VAC inputs for open and closed limit switches and 2 general purpose inputs
- Simple 4-wire Modbus-485 communication network includes supervisory power
- Robust communication, up to 500m cable length
- Plugable terminal strips for easy field installation
- Direct mounting within the actuator
- Low power consumption; does not require ventilation
- Electronic overload protection with built-in current monitoring optional
- High power outputs can directly drive small motors
- LED indicators on inputs, outputs and communication channel
- Automatic calibration using local push button or remote command
- Multi-vendor PLC support through the standard Modbus communication module

Typical Applications

- Blending of bulk materials
- Petroleum products and other liquids flow control
- Level control for maintaining process supply

Application

The Modbus is an application specific controller, designed for positioning electric actuators using rotary feedback. Typical devices include rotary and linear actuators. Feedback may be via a potentiometer or a quadrature optical encoder. Controller outputs can drive small electric motors or motor starters directly.

A Modbus-485 communication network allows up to 100 devices on a single channel. The Modbus is powered by 24VDC and provides four supervisory inputs, configurable as limit switches or force open/close signals.

Automatic calibration is provided which requires no loop tuning. All operating parameters can be set as registers in the Modbus communications map.

Specifications

Actuator

Voltage	120/240VAC 1Ø
Current	4A (2 minute 25% duty-cycle)
Fuse	GMA 4 replaceable

Supervisory

Voltage	10 to 25VDC
Current	30mA @ 24VDC

Auxiliary Inputs

Voltage	120/240VAC
Current	min 10mA / max 20mA

Communication

Standard Modbus-RS485 differential	
Distance	500m (1,640ft.)
Input Load	12K ohm, standard
Termination	120Ω balanced line

Position

Resolution	12 bit (1 part in 4096)
Accuracy	0.1% full scale
Potentiometer	1000Ω typical (500 to 10kΩ)
Quadrature	
Optical Encoder	1000 to 4096 pulses

Environment

Temperature	-40°C to +70°C (-40°F to +158°F)
Relative Humidity	0 to 95% non-condensing

Dimensions

Length	96mm (3.75 in)
Width	70mm (2.75 in)
Height	36mm (1.40 in)

Accessories

RCS electric actuators can be supplied with a selection of accessories to adapt to specific control demands and automation requirements.

- Integral potentiometer – Available in a variety of resistance ranges to interface with most common control devices; available for all models of RCS actuators.
- Auxiliary limit switches – Available in SPDT or DPDT configurations for additional control requirements and are independently adjustable.
- Interposing relays – Available with a variety of coil voltages to allow for operation when the control voltage differs from the actuator supply voltage.

Single and dual relay configuration are available for specific applications.

- Motor brakes – Maintains actuator position and minimizes back drive created by dynamic torque in certain valve and flow applications. (Standard feature on all SurePowr models and modulating service applications)
- D.C. analog position transmitter (with integral power supply) – Provides analog position indication proportional to actuator travel.
- D.C. analog position controller – The ACT-100 analog control module is capable of being configured to a variety of common control input and output signals and features self-calibrating technology. A variety of embedded control and setting menus provide for precise settings to satisfy complex loop control demands.
- Digi-Tork bi-directional torque control – Electronic current sensing device which protects the actuator from damage created by excessive torque demands.
- Digi-Speed variable speed control – Electronic timer that allows for extension of actuator cycle time to minimize water hammer or any other piping shock created by sudden flow reversal within a piping system.
- Communication bus interface modules:
 - Profibus DP
 - DeviceNet™
 - Modbus
- Specialized wiring configurations – RCS actuators can be provided with internal wiring and modifications to address process requirements such as extended travel, multi-stop, interlock signals and other unique requirements.



**Industrial Products Group
RCS Actuators**

16240 Port Northwest Drive
Houston, TX 77041

T: 832-590-2306

Toll Free: 1-800-945-9898

F: 713-849-2879

*© 2020 Natural Gas Solutions North America, LLC – All rights reserved.
Natural Gas Solutions reserves the right to make changes in specifications
and features shown herein, or discontinue the product described at any
time without notice or obligation. Contact your Dresser Natural Gas Solu-
tions representative for the most current information. The Dresser Logo and
all Trademarks containing the term "Dresser" are the property of Dresser,
LLC, a subsidiary of Baker Hughes, a GE Company.*



www.dresserngs.com

RCS Actuators Catalog NGS.IPG.0016c

10.20