

Surepowr Series Sure 150

Installation Manual

Table of Contents

Intended of Usage	2
Actuator Range of Application	2
1. Actuator Marking.....	3
2. Special Conditions for Safe Use (ATEX)/Conditions of Certification (IECEX)	3
3. Ratings	3
4. Safety	4
Safety First!	4
Warnings and Notices.....	4
Joint Handling	4
Fasteners.....	5
Seals.....	5
Cable Glands	5
Grounding and Bonding	5
Spring Housing.....	5
Enclosure Surface Temperature.....	5
5. Installation.....	6
Dimensional Information	6
Dimensional Information	7
Cover Removal and Assembly.....	8
Mounting.....	8
Horizontal Mounting	8
Conduit Locations and Thread Sizes.....	9
Cable Glands	9
Grounding and Bonding	9

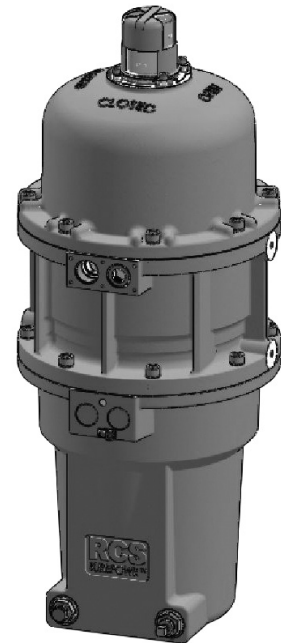

Wiring.....	9
Wiring Diagrams.....	9
Mechanical Stop Settings	11
Limit Switch Settings	11
Switch adjustments for clockwise spring fail operation (viewed from the top of the actuator).....	11
Switch adjustments for counter-clockwise spring fail operation (viewed from the top of the actuator).....	11
Limit Switch Settings (Optional Offering)	12
Installation.....	12
6. Operation.....	13
Thermal Overload	13
Duty Cycle	13
Optional Manual Override.....	13
7. Maintenance.....	13
Mounting Fasteners	13
Enclosure Cover Screws	13
Seals and Cable Glands.....	14
8. Storage.....	14

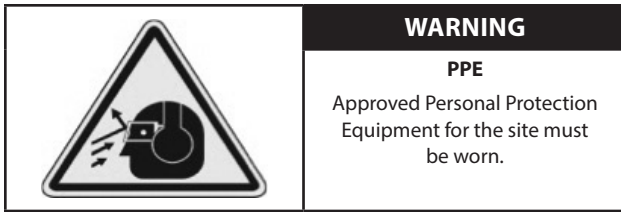

This manual gives instructions for storing, installing, operating and servicing the RCS Surepowr* Series

Sure 150 electrical mechanical actuator. Refer all questions not covered in this manual to:

Dresser Utility Solutions
16240 Port Northwest Drive Houston, TX 77041
Tel. 832-590-2306 Fax. 713-849-2879

Be sure to include the model and serial number located on the nameplate of your Sure 150 actuator in all communications and parts orders. The nameplate is located on the bottom portion of the spring housing.

Follow local / regional electrical safety laws and regulations.

Intended of Usage

Make Special Note of the following information regarding intended use for this equipment.

Consult the following documents for intended use standards:

- a) EN(IEC)60079-14 standard
(Explosive Atmospheres – Part 14: Electrical Installations Design, Selection and Erection)
- b) EN(IEC)60079-17 standard
(Explosive Atmospheres – Part 17: Electrical Installations Inspection and Maintenance)
- c) Any laws, decrees, standards, procedures or other documents related to the area in which the actuator shall be installed

Dresser Utility Solutions cannot be held responsible if these standards are disregarded.

Check the compatibility of the actuator's nameplate markings with the classification of the installation area's environment and its ambient and admissible surface temperatures.

Only qualified, certified and properly trained personnel should conduct actuator installation and maintenance.

Actuator Range of Application

For use in EU countries, IEC participating countries and any others that accept ATEX/ IECEx certification

This device is designed to meet CE Machinery directive 2004/42/EC (EN 12100:2010, EN 14121-1:2007) and Electromagnetic Compatibility (EMC) Directive 2004/108/EC (EN 61000-6-4: 2007, EN 61000-6-2: 2005).

For use in North American "Class, Division" Classified Areas:

This device is designed for installation in Class I, Division 1 Groups C and D and Class II, Division 1 Groups E, F and G rated environments within an operating temperature range of -40°C to +65°C.

1. Actuator Marking

	ATEX Explosion Proof Enclosure "d"/Dust Protection by Enclosure "Tb"	North American Class/Div. Europe CE marking
Name and Address of Manufacturer	Dresser Utility Solutions 16240 Port Northwest Drive Houston, TX 77041	Dresser Utility Solutions 16240 Port Northwest Drive Houston, TX 77041
Actuator Type	Electrical Mechanical Surepower Series	Electrical Mechanical Surepower Series
Certificate Number	SIRA 15 ATEX 1058x/IECEX SIR 15,0034X	Master Contract: 157578
Specific Marking	ex II 2 GD; -NN°C > Ta > 65°C	
No. of notified audit body	Sira 15 ATEX 1058x	CSA
Gas Marking	Ex d IIB T5 Gb	Class I, Div I, Grp. C,D
Dust Marking	Ex tb IIIC T85°C DbAmbient Temperature	Class II, Div I Grp E, F, G
Ambient Temperature	-20°C (-4°F) to +65°C (150°F)	-40°C (-40°F) to +65°C (150°F)
Note	Any temperature below -20°C (-4°F) (over pressure test required)	
CE Marking	Machinery Directive; 2004/42/EC (EN 12100:2010, EN 14121-1:2007)	NA
CE Marking	EMC Directive; 2004/108/EC (EN 61000-6-4:2007, EN 61000-6-2:2005)	NA

NOTICE:

The Actuator Marking Plate shall not be damaged, covered up or painted over. Actuator identification and specifications must remain visible.

2. Special Conditions for Safe Use (ATEX)/Conditions of Certification (IECEX)

- The equipment uses M10x1.5 stainless steel special fasteners of grade A4-80 and yield strength 600 MPa. If fasteners are replaced, they shall be replaced with the equivalent size and grade.
- Some external parts of the equipment are non-conducting and may generate an ignition-capable level of electrostatic charge under certain extreme conditions. Ensure that the equipment is not installed in a location where it may be subjected to external conditions (such as high-pressure steam) that might cause build-up of electrostatic charges on non-conducting surfaces. Additionally, the equipment should be cleaned with a damp cloth.
- The equipment contains flamepaths that are other than the relevant minimum or maximum dimensions as specified in IEC 60079-1:2012 Table 1. The essential parameters are:

Flamepath	Type	Min. design length	Max. design gap
Cover to Shaft	Cylindrical	25.89 mm	0.10 mm
Cover to Gear Case	Flange	23.39 mm	.0762 mm
Gear Case to Spring Housing	Flange	23.37 mm	.0762 mm
Shaft to Yoke	Spigot	19.40 mm	.08 mm
Yoke to Spring Housing	Rabbit	26.14 mm	.0762 mm (flange) .1mm (cylinder)

3. Ratings

Power [kW]	Sure 150
Nominal Supply Voltage [V]	115/120; 220/230 (VAC) (50/60 Hz)
Nominal Current [A]	1.9
Nominal Torque [Nm]	136
Duty Cycle (max frequency)	25
Temperature	See Above
Protection Class	d
Weight	120 lb (55kg)

The actuator has been tested and certified for Ingress Protection IP 66/67 and type 4, 4X & 6.

4. Safety

Safety First!

In the maintenance and operation of mechanical equipment, safety must be considered at all times. Through the use of the proper clothes, tools, and methods of handling, serious accidents can be prevented.

A number of safety precautions are listed throughout this manual. Study them carefully and follow them, and insist that those working for and with you do the same. Remember, an accident is usually caused by carelessness, neglect, or oversight.

Warnings and Notices

Pictograms are used throughout this manual to denote important or dangerous situations. If warnings are not respected, dangerous situations may result that may cause serious personal injury or death. Examples of the pictograms throughout this manual:

	WARNING
	GROUNDING LUG: Unit must be grounded with minimum size 10 AWG wire.

WARNING
Indicates a hazardous situation that, if not avoided, could result in death or serious injury.

	WARNING
	ELECTRICAL SHOCK WARNING: Indicates a risk of death or serious injury due to electrical shock if safety measures are not adhered to.

NOTICE:
Indicates practices not related to personal injury, but addresses important information regarding the installation, operation or maintenance of the unit.

CAUTION:
Indicates a potentially hazardous situation that, if not avoided, can result in minor to moderate injury, or serious damage to the product. The situation described in the CAUTION may, if not avoided, lead to serious results. Important safety measures are described in CAUTION (as well as WARNING), so be sure to observe them.

Observe these and all other warnings at all times during installation, operation and maintenance of this product:

	WARNING
	EXPLOSION HAZARD Death or serious injury could result. Do not open unless power to actuator has been disconnected.

	WARNING
	EXPLOSION HAZARD Death or serious injury could result. Do not open if an explosive atmosphere may be present.

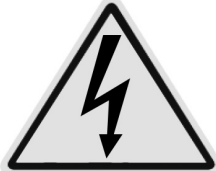
	WARNING
	ELECTRICAL SHOCK WARNING: Indicates a risk of death or serious injury due to electrical shock if safety measures are not adhered to.

	WARNING
	HIGH ENERGY HAZARD Death or serious injury could result. Do not attempt to repair actuator unless properly trained in specific repair methods for this device.

Joint Handling

	WARNING
	LIFTING HAZARD May result in injury. See safety manual for lifting instructions

	WARNING
	EXPLOSION HAZARD Death or serious injury could result. Do not open unless power to actuator has been disconnected.

	WARNING
	EXPLOSION HAZARD Death or serious injury could result. Do not open if an explosive atmosphere may be present.

Do not open actuator cover if there is risk of an explosive environment. Care must be taken with the joint surface when handling, installing or storing to preserve the integrity of the explosion-proof joint. See joint handling instructions under the Installation section of this manual. Failure to observe these instructions may compromise the enclosure protection rating.

Fasteners

Both Metric and Imperial fasteners used, use applicable tools. The enclosure cover bolts and the hard stop assembly are metric threads and the rest of the others are imperial threads.

All fasteners must be intact and properly tightened. Enclosure cover screws, mounting fasteners and cable glands must be tightened to specified torque values. Failure to maintain specified torque for cover screws and cable glands may compromise the enclosure protection rating. Failure to maintain specified torque for mounting fasteners may compromise actuator operation. See **Installation and Maintenance sections** of this manual for specified fastener and torque requirements, as well as safety and maintenance information.

	WARNING
	<p>EXPLOSION HAZARD</p> <p>Death or serious injury could result.</p> <p>Maintain cover screw and cable gland fastener torque specifications to ensure enclosure protection.</p>

Seals

All seals must be routinely checked to ensure that they are in good condition, properly sealed and replaced as needed. Failure to do so may compromise the enclosure protection rating. **See Installation and Maintenance sections for instructions.**

	WARNING
	<p>EXPLOSION HAZARD</p> <p>Death or serious injury could result.</p> <p>Maintain all seals to ensure enclosure protection.</p>

Cable Glands

Cable glands must be installed and maintained and properly torqued according to the Installation and Maintenance specifications. Failure to do so may compromise the enclosure protection rating.

See Installation and Maintenance sections for instructions.

	WARNING
	<p>EXPLOSION HAZARD</p> <p>Death or serious injury could result.</p> <p>Maintain cable gland torque specifications to ensure enclosure protection.</p>

Grounding and Bonding

Failure to properly ground or bond the device may result in death or serious injury due to explosive hazards.

See Bonding and Grounding under the Installation section of this manual for proper specifications.

	WARNING
	<p>EXPLOSION HAZARD</p> <p>Death or serious injury could result.</p> <p>Ensure device is properly grounded to avoid explosion hazard.</p>

Spring Housing

Caution:
<p>Loaded spring inside actuator.</p> <p>Do not attempt to repair actuator below top gear plate, unless properly trained on repair methods.</p>

Enclosure Surface Temperature

Enclosure surface temperature may be higher due to operation. This could result in burns to the operator's hand if touched while the enclosure is hot. Please allow the enclosure to cool to the specified ambient temperature range before touching the enclosure for handling.

	WARNING
	<p>BURN HAZARD</p> <p>Hot surface inside.</p> <p>Allow to cool before servicing.</p>

5. Installation

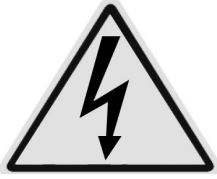

WARNING

HIGH ENERGY HAZARD - LOADED SPRING

Death or serious injury could result.

Do not attempt to repair actuator unless properly trained in specific repair methods for this device.

Notice:

SurePowr actuators can be supplied for clockwise or counter-clockwise spring-driven rotation (viewed from the top of the actuator). The spring drive rotation is noted on the actuator name tag and wiring diagram. Ensure that the actuator has been supplied with the proper spring drive operation for the application prior to installation on the driven device.

Dimensional Information

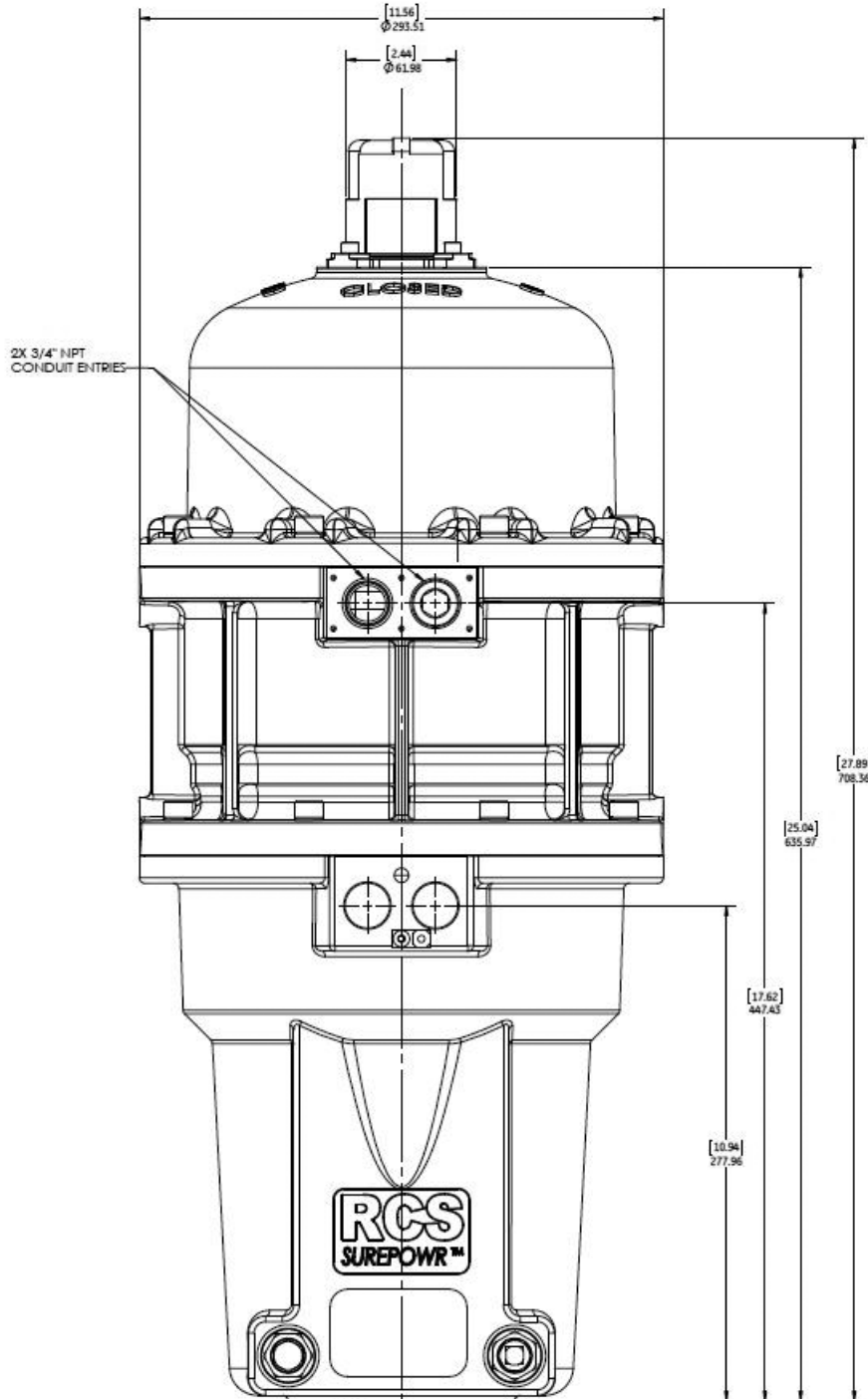

Figure 1

Dimensional Information

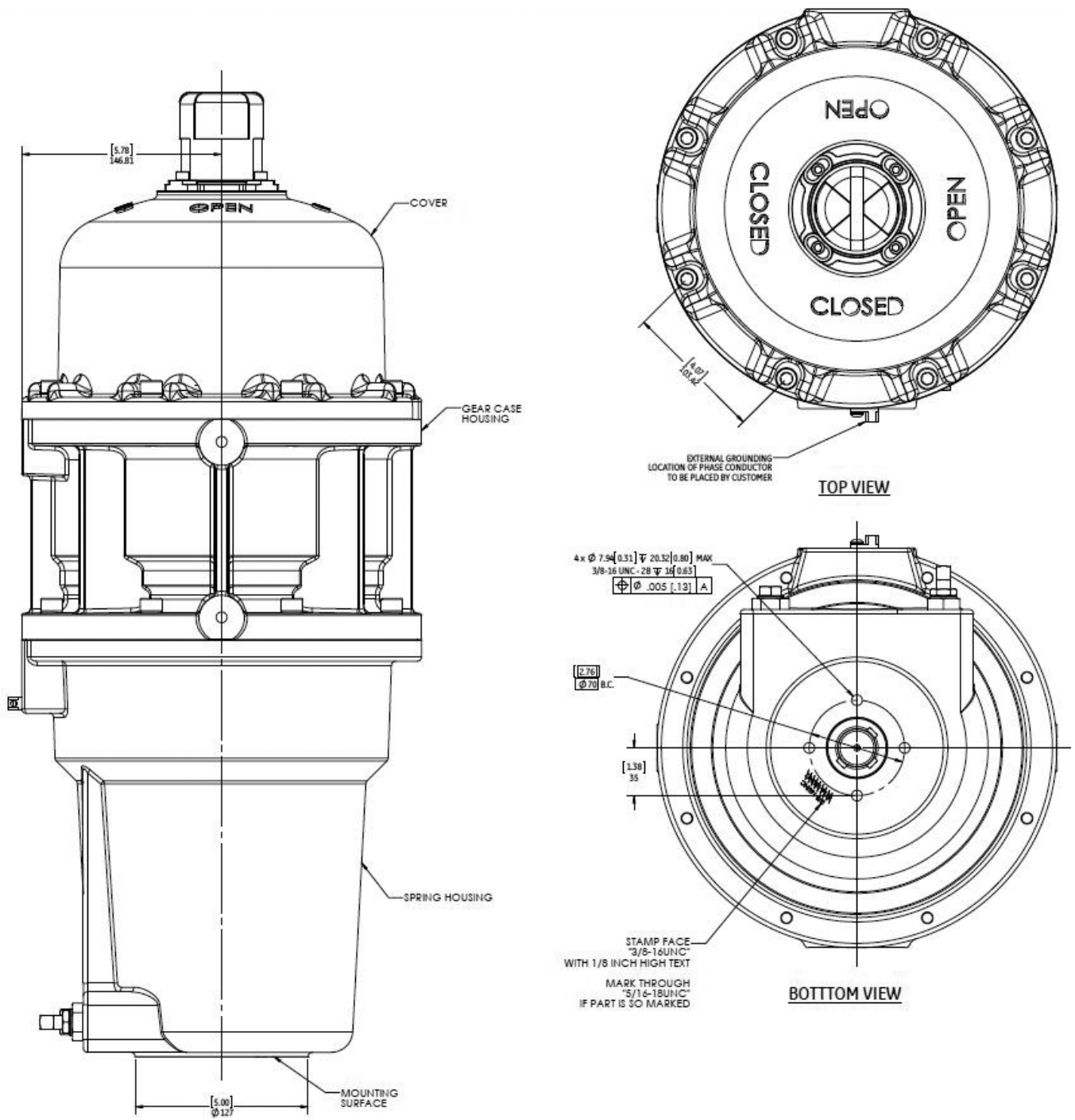



Figure 2

Cover Removal and Assembly

Do not open the actuator cover if there is risk of an explosive environment.

	<p>WARNING</p> <p>EXPLOSION HAZARD – REMOVE POWER</p> <p>Death or serious injury could result.</p> <p>Do not open unless power to actuator has been disconnected.</p>
---	---

	<p>WARNING</p> <p>EXPLOSIVE ATMOSPHERE HAZARD</p> <p>Death or serious injury could result.</p> <p>Do not open if an explosive atmosphere may be present.</p>
---	--

Do not store or set the actuator cover with the flange surface down. To preserve the explosion-proof integrity of the joint, care must be taken not to damage, scuff or score the flange joint surfaces and associated parts (cable glands, joints, etc.). Take care not to damage the cover joint when replacing the cover onto the actuator housing. Ensure that the joint is clean and free of debris or damage and ensure that the O-ring is intact and in place before replacing the cover onto the actuator housing. The explosion-proof joint may be lubricated with an appropriate, non-corrosive, non-hardening grease, such as Vaseline.

When replacing the actuator cover, ensure the eight cover screws are tightened to specified torque value and that all screws are intact. Failure to maintain specified screw torque may compromise the enclosure protection rating.

Under normal operation, the capacitor will discharge prior to the removal of the cover.

Enclosure cover screw specifications:

Exd or EEx d versions:
8, 10mm x 1.5 x 35 mm,
A4-80 Stainless steel,
apply anti-freeze compound;
torque to 32-33 ft.-lbs. (43-44 N.m)

	<p>WARNING</p> <p>EXPLOSION HAZARD</p> <p>Death or serious injury could result.</p> <p>Maintain cover screw torque specifications to avoid hazard.</p>
---	--

Mounting

The actuator is shipped in the fail safe position. Ensure that the driven device is oriented to its desired fail position prior to installation or any maintenance work of the actuator.

Care should be taken to maintain proper alignment between the actuator and the device shaft. The actuator should install on the shaft without binding. The mounting face should be centered on the bracket without binding or side load.

Mount the actuator to the device. Ensure the actuator is centered properly with the device shaft, and then tighten all screws and nuts to the mounting fastener spec. below.

Mounting Fastener Specifications:

4, 3/8"-16 UNC, grade 8 or equivalent,
torqued to 45 in/lbs

Horizontal Mounting

Although the actuator is suitable for mounting in any orientation, additional support is required at the lifting lug screw holes for horizontal mounting (**Figure 3**).

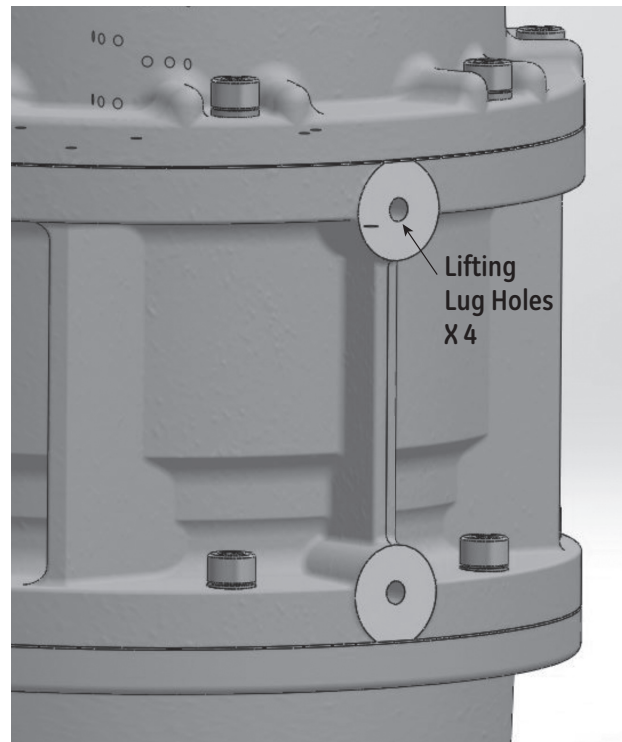

Figure 3

Conduit Locations and Thread Sizes

The actuator is supplied with two 2 3/4-inch NPT conduit entries. Refer to **Figure 1** (Sure 150 outline drawing) for conduit entry locations.

Cable Glands

Ensure that the cable glands and wiring conform to the applicable Explosion-Proof Equipment Standards and to the Explosion-Proof Classification.

If an adapter is necessary to fit a cable gland, only one adapter is allowed at cable entry.

If one of the cable entries is not used, it should be sealed with a certified metal plug, without an adapter.

Cable glands should be fastened firmly to prevent ingress of water or dirt and should be tightened to the manufacturer's specified torque to ensure the required enclosure protection.

Grounding and Bonding

The internal and external grounding points are electrically connected within the actuator. The internal grounding point is a green grounding screw located on the surface of the top gear plate near the conduit entry. The external grounding point location is shown in **Figure 4**.

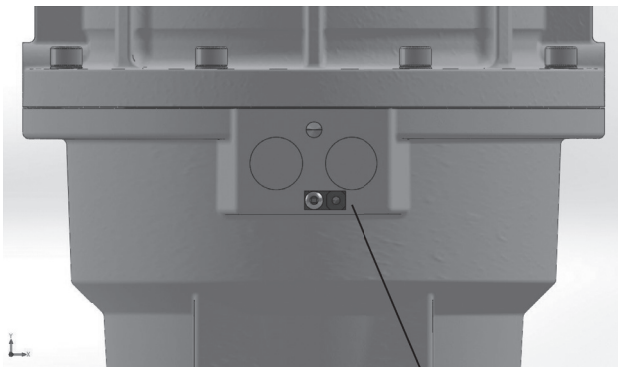

Location of External Grounding with Screw

Figure 4

Wiring

Connect field wiring per the appropriate wiring diagram supplied with the actuator.

NOTICE:

Use a minimum of #18 AWG stranded wire.

Wiring Diagrams

Wiring diagrams vary according to specific product configuration. Refer to the wiring diagram supplied with the actuator.

NOTICE:

Units should be connected using the wiring diagram supplied with the actuator.

NOTICE:

Direction of rotation is based on viewing the actuator from the top.

NOTICE:

To operate multiple actuators in parallel from a single source requires isolating relays in the field wiring.

FIELD WIRING

ACTUATOR WIRING

ALL WIRING SHOWN INSIDE DASHED LINE IS PROVIDED ON CIRCUIT BOARD.

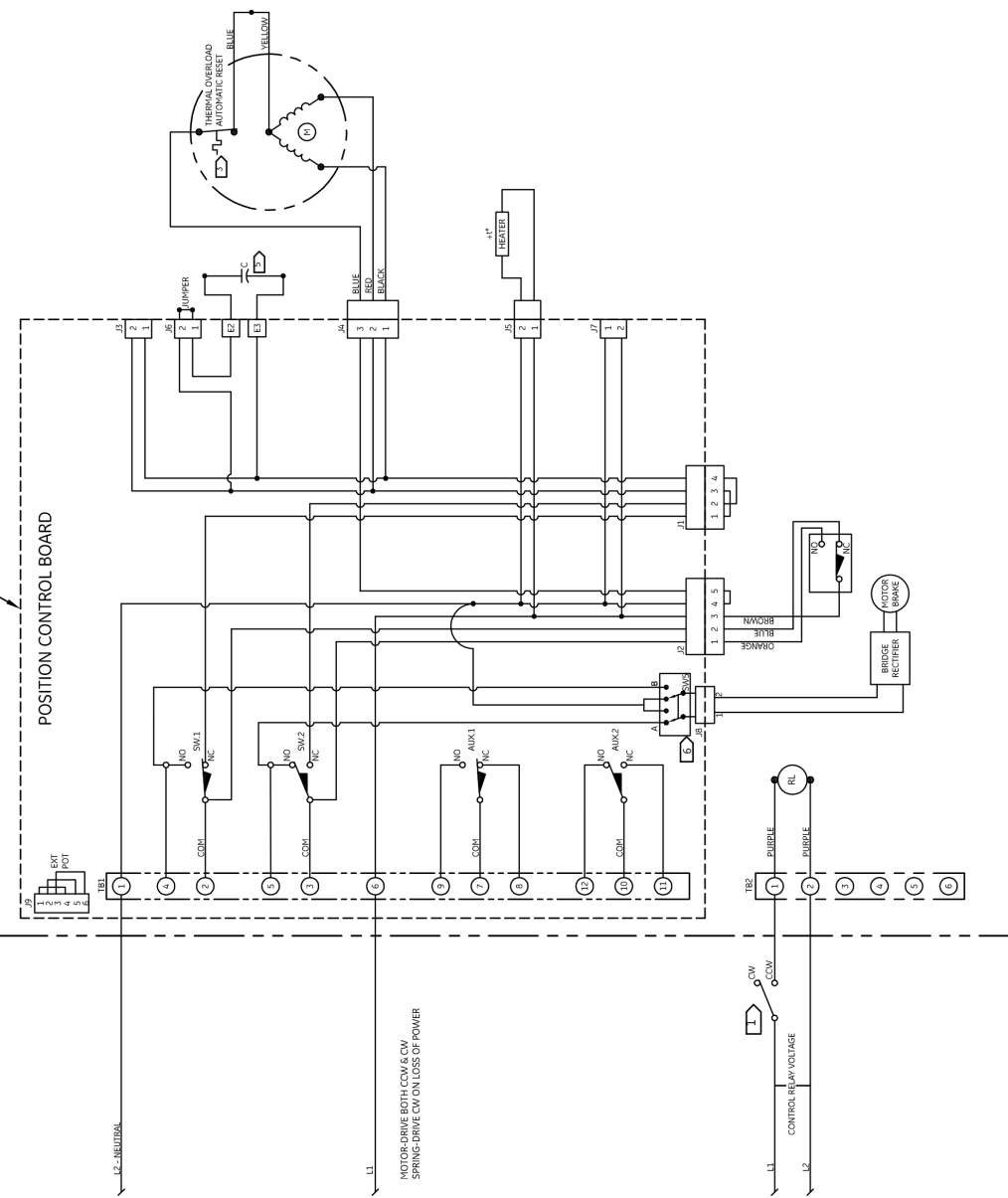

- STANDARD NOTES:**
- FIELD SWITCH SHOWN FOR ILLUSTRATION ONLY.
 - WIRING DIAGRAM SHOWS ACTUATOR IN FULL CW POSITION WHEN LOOKING FROM TOP. CONTROL COVER END OF ACTUATOR.
 - THE THERMAL SWITCH THAT IS EMBEDDED IN THE MOTOR WINDINGS OPENS AT 120°C (250°F) TO DISABLE AND PROTECT THE MOTOR.
 - SYMBOL (A) INDICATES TERMINAL BLOCK CONNECTIONS IN THE ACTUATOR.
 - SEE RVT TO SECURE CAPACITOR TO BOARD.
 - SWITCH SW2 TO BE SET TO "H" FOR CW UNITS.
- OPERATION NOTES:**
- POWER TO TERMINAL 1, TERMINAL 6 AND ENERGIZE RELAY COIL WILL MOTOR-DRIVE AND BRAKE HOLD ACTUATOR IN FULL CW POSITION.
 - POWER TO TERMINAL 1, TERMINAL 6 AND DE-ENERGIZE COIL WILL MOTOR-DRIVE & SPRING HOLD ACTUATOR IN FULL CW POSITION.
 - LOSS OF POWER WILL SPRING-DRIVE AND SPRING HOLD ACTUATOR IN FULL CW POSITION.



LIMIT SWITCH CONTACT DEVELOPMENT

CURRENT DIRECTION	SWITCH NUMBER	TERMINAL POS.	100% FULL CW	75% FULL CW	25% FULL CW	0% FULL CW
CW	1	N.O.	○	○	○	○
	2	N.C.	○	○	○	○
	3	N.O.	○	○	○	○
	4	N.C.	○	○	○	○
CCW	1	N.O.	○	○	○	○
	2	N.C.	○	○	○	○
	3	N.O.	○	○	○	○
	4	N.C.	○	○	○	○

CLOSED SWITCH CONTACT POSITION SHOWN IN ILLUSTRATION. THESE AUXILIARY SWITCHES MAY BE SET TO OPERATE AT ANY ACTUATOR POSITION.

GE

GREEN GROUND SCREW

DESCRIPTION: TYPICAL WIRING DIAGRAM, SURE 100/150

REVISIONS:

REV	SCALE	DESCRIPTION	DATE	SHEET	SIZE
1		INTERPRET DRAWING PER ASME Y14.5 THIRD ANGLE PROJECTION			

VENDOR INFO*

ALL VENDOR ALLOWED? YES NO

EQUIVALENT PRODUCT ALLOWED? YES NO

REVISIONS (DATE)

APPROVED BY (SIGNATURE)

DESIGNED BY (SIGNATURE)

CONTRACT ENGINEERING

Mechanical Stop Settings

NOTICE:

Only the fail end of travel stop may be adjusted.
The total adjustment available is +/- 5°.

To adjust the fail end position, perform the following:

- Use the adjustable, square, end of travel stop screw to adjust the fail end of travel position (**Figure 2**).
- To make the end of travel stop adjustment, first loosen the 3/8-inch lock nut to free the adjustment screw, then turn the square adjustment screw.
- Be sure to re-tighten the lock nut in order to maintain the enclosure rating.

NOTICE:

Do not loosen the large, 5/8-inch bolt in the adjustment screw assembly. This will result in spring release and will remove the spring pre-load.

NOTICE:

After adjusting the end stop, be sure to adjust the actuator limit switches.

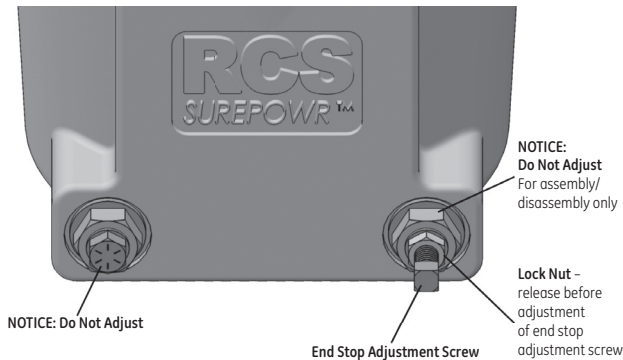

Figure 5

Clock-Wise Spring Return Shown

(Counter Clock-Wise orientation will be seen as a mirror image)

Limit Switch Settings

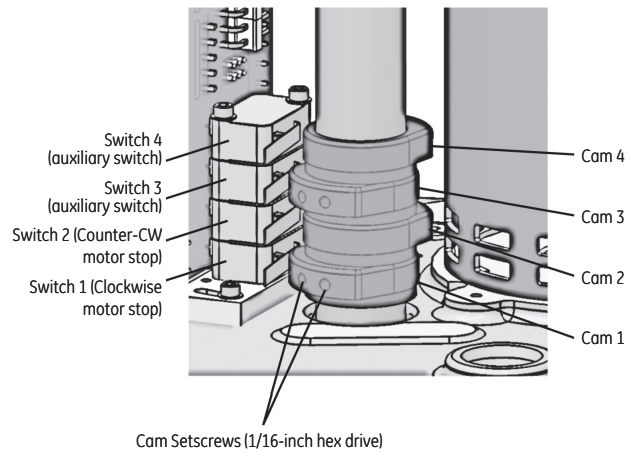
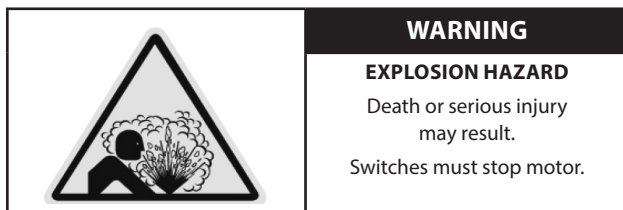

Figure 6

Switch adjustments for clockwise spring fail operation (viewed from the top of the actuator)
Cam 1 actuates the clockwise motor stop switch.

Cam 2 actuates the counter-clockwise motor stop switch.

Cams 3 and 4 are auxiliary switches.

To set the clockwise (spring fail position) switch:

- Ensure the actuator is positioned in the clockwise (fail) position. Ensure the end of travel stop is properly adjusted (see Mechanical Stop Setting section). Loosen the setscrews on Cam 1 (1/16-inch hex drive). Rotate Cam 1 counter-clockwise away from its switch until it clears the switch lever.
- Rotate Cam 1 clockwise until it comes in contact with its switch lever and the switch “breaks” (a light “click” can be heard). Continue to rotate the cam slightly in the clockwise direction; this ensures that the motor will be switched off before the actuator reaches its end of travel stop. Tighten the setscrews on Cam 1.

To set the counter-clockwise switch:

With the actuator in its full counter-clockwise position, loosen set screws on Cam 2 so as to trip Switch 2 at this position.

Auxiliary Switches:

Set Cams 3 and 4 to trip auxiliary switches as required for the application.

Replace the cover and cover screws in accordance with the specifications stated in the Installation section of this manual.

Switch adjustments for counter-clockwise spring fail operation (viewed from the top of the actuator)

Cam 1 actuates the clockwise motor stop switch.

Cam 2 actuates the counter-clockwise motor stop switch.

Cams 3 and 4 are auxiliary switches.

To set the counter-clockwise (spring fail position) switch:

- Ensure the actuator is positioned in the counter-clockwise (fail) position. Ensure the end of travel stop is properly adjusted (see Mechanical Stop Setting section). Loosen the setscrews on Cam 2 (1/16-inch hex drive). Rotate Cam 2 clockwise away from its switch until it clears the switch lever.
- Rotate Cam 2 counter-clockwise until it comes in contact with its switch lever and the switch “breaks” (a light “click” can be heard). Continue to rotate the cam slightly in the counter-clockwise direction; this ensures that the motor will be switched off before the actuator reaches its end of travel stop. Tighten the setscrews on Cam 2.

To set the clockwise switch:

With the actuator in its full clockwise position, loosen set screws on Cam 1 so as to trip Switch 1 at this position.

Auxiliary Switches:

Set Cams 3 and 4 to trip auxiliary switches as required for the application.

Replace the cover and cover the screws in accordance with the specifications stated in the Installation section of this manual.

Limit Switch Settings (Optional Offering)

Installation

NOTE:

SurePowr actuators can be supplied for clockwise or counter-clockwise spring-driven rotation (viewed from the top of the actuator). The spring drive rotation is noted on the actuator name tag and wiring diagram. Ensure that the actuator has been supplied with the proper spring drive operation for the application prior to installation on the driven device.

- The actuator is shipped in the power off (fail) position. Ensure that the driven device is oriented to its fail position prior to installation of the actuator.
- Care should be taken to maintain proper alignment between the actuator and the device shaft. If the actuator is not in the correct alignment with the device shaft, repeat the procedure in Step 1.
- Mount the actuator to the device. Ensure the actuator is centered properly with the device shaft, and then tighten all bolts and nuts evenly.
- Remove the cover bolts located around the actuator motor and control cover flange.
- Terminate field wiring per the appropriate RCS wiring diagram supplied with the actuator. Use a minimum of #18 AWG stranded wire.

NOTE:

Ensure the driven device is properly positioned in its full fail position. If it is not, use the adjustable end of travel stop on the Sure 100 (see Figure 4) to properly adjust the fail end of travel stop. Only the fail end of travel may be adjusted. Loosen the lock nut to free the adjusting screw, then use a wrench to turn the screw. The total adjustment available is +/- 5°.

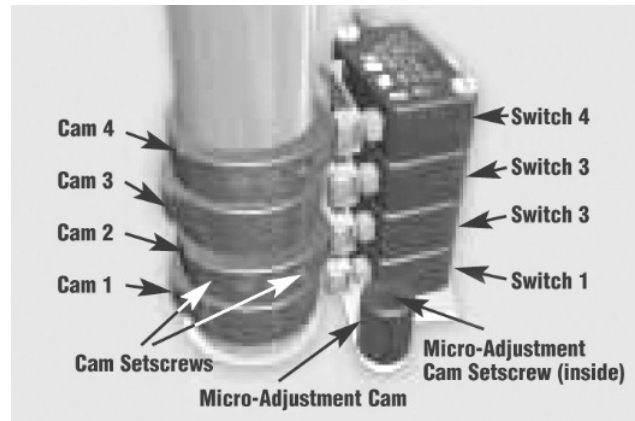

Figure 7

Switch adjustments for clockwise spring fail operation (viewed from the top of the actuator)

- Ensure the actuator is de-energized and positioned in the clockwise (fail) position. Ensure the end of travel stop is properly adjusted. Rotate the screw clockwise to move the actuator output shaft in a counter-clockwise direction. Rotate the screw in a counter-clockwise direction to move the actuator output shaft in a clockwise direction. Loosen the setscrews on Cams 1 and 3. Rotate both counter-clockwise until they clear the switch arm rollers of Switches 1 and 3.
- Rotate Cam 1 clockwise until it comes in contact with Switch 1’s arm roller and the switch “breaks”. A light “click” can be heard. Tighten the setscrews on Cam 1.
- Rotate Cam 3 clockwise until it comes in contact with Switch 3’s arm roller and the switch just “breaks”. A light “click” can be heard.
- Rotate Cam 3 slightly further in the clockwise direction. This ensures that Switch 3 will “break” just prior to the actuator reaching the full fail position. Tighten the setscrews on Cam 3. Energize the actuator. This will move the actuator to the opposite end of travel.

CAUTION:

Equipment Operation

Closely monitor the electrical stroke, as the travel limit switches are not yet properly adjusted. Ensure the actuator does not over-travel and damage the driven equipment.

6. Operation

Power On: The electric motor drives the gear train, which in turn winds the spring and turns the device. An internal limit switch de-energizes the motor and energizes the brake, which holds the return spring and device in position.

Power Off: When the current is interrupted by either a control signal or a power failure, the return spring drives the device to its original position.

NOTICE:

To prolong cycle life, it is recommended that the actuator be driven electrically in both directions for normal operation.

Thermal Overload

The internal thermal overload switch de-energizes the motor and prevents overheating of the motor windings due to excessive operation, stalling or high ambient temperatures. De-energizing the motor due to thermal overload will result in actuator spring-driving to the power loss position.

Duty Cycle

The maximum duty-cycle to be expected without interruption by thermal cut-off at an ambient temperature of 65C° (150°F) is 25 percent (three "OFF" times for every one "ON" time).

Optional Manual Override

The optional Manual Override can be used to position the actuator when no power is available.

Failure to respect these Notices may result in damage to the device:

NOTICE:

Do not engage Manual Override while power is applied to the actuator.

NOTICE:

Do not disengage Manual Override while it is under load.

NOTICE:

Do not apply power to the actuator while Manual Override is engaged.

Engage Manual Override by releasing the latching lever and rotating the handle 90 degrees. It is helpful to rotate the hand wheel back and forth slightly during this operation to assist in gear tooth engagement. After the handle has been latched into the new orientation, rotate the hand wheel to position the actuator. Take care not to run the actuator tightly into either of the travel stops as this may cause damage to the actuator. Position the actuator in its spring fail position before disengaging Manual Override. Do not disengage Manual Override while the hand wheel is under load.

7. Maintenance

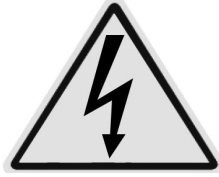
	WARNING
	HIGH ENERGY HAZARD – LOADED SPRING Death or serious injury could result. Do not attempt to repair the actuator unless properly trained in specific repair methods for this device.

Only qualified, certified and properly trained personnel shall conduct actuator maintenance.

The gear train is permanently lubricated at the factory for the average life of the actuator. No further attention is required.

Commissioned actuators should be checked routinely for damage to paint finish, and touchup paint can be applied where necessary to prevent corrosion.

Actuators that are infrequently operated should be tested every six months to ensure they are ready to operate.

The actuator shall be set to fail safe or pre set position before starting any maintenance work. Turn off the power if it is not required for maintenance work. Remove pre load when necessary, if in doubt, contact the manufacturer.

Steps in removing spring pre-load.

1. Uncouple the actuator from the driven object.
2. Apply electric power to the actuator brake.
3. Back out motor end hard stop. It will not come out completely. It is designed not to come out completely.
4. Back out the spring end of hard stop.
5. Turn off the power to the brake. The spring will back drive motor and gear train.
6. Use a wrench to rotate the output shaft back and forth to ensure spring pre load is released.

Mounting Fasteners

For Mounting Fastener Specifications, refer to the Installation section of this manual.

Six months after commissioning, and annually thereafter, check fasteners between the actuator and the driven device for tightness. If required, tighten fasteners, being sure to apply the correct specified torque. Failure to maintain specified torque may compromise actuator operation.

Enclosure Cover Screws

For enclosure cover screw specifications and torque, refer to the Installation section of this manual.

Six months after commissioning, and annually thereafter, check the actuator cover screws for tightness. If required, tighten screws applying the

correct specified torque. Failure to maintain specified screw torque may compromise the enclosure protection rating.

The explosion-proof joint may be lubricated with an appropriate, non-corrosive, non-hardening grease, such as Vaseline.

	WARNING
	EXPLOSION HAZARD Death or serious injury could result. Maintain cover screw torque specifications to ensure enclosure protection.

Seals and Cable Glands

Elastomer-based seals may degrade as they age; the seals must be checked regularly and replaced as needed. When replacing seals, be sure the sealing surfaces are clean.

O-rings should be checked regularly to ensure they are in good condition and placed correctly, and that the sealing faces are clean. You may apply a thin film of non-acidic grease, such as Vaseline, to the sealing faces.

Cable glands should be checked regularly to ensure they are tightening according to specifications, to prevent ingress of water or dirt. Routinely check that cable glands are tightened to the manufacturer's specified torque to ensure the required enclosure protection.

	WARNING
	EXPLOSION HAZARD Death or serious injury could result. Maintain cable gland torque specifications to ensure enclosure protection.

8. Storage

The Surepowr actuator must be stored in a clean, dry, temperature-controlled building that is protected from the weather. Precautions should be taken to prevent condensation inside or outside the actuator. If there is insufficient external temperature and humidity control, the internal heaters must be energized to protect the unit against condensation from extreme temperature variations. The actuators should be stored off the floor on suitable pallets and must be covered with an unsealed dust protector allowing side and bottom ventilation. Conduit entries must be sealed with the shipping plugs provided or other suitable means. The control cover should be installed.

RCS Actuators

16240 Port Northwest Drive

Houston, TX 77041

T: 832-590-2306

Toll Free: 1-800-945-9898

F: 713-849-2879

© 2021 Natural Gas Solutions North America, LLC – All rights reserved. Dresser Utility Solutions reserves the right to make changes in specifications and features shown herein, or discontinue the product described at any time without notice or obligation. Contact your Dresser Utility Solutions representative for the most current information. The Dresser Logo and all Trademarks containing the term "Dresser" are the property of Dresser, LLC, a subsidiary of Baker Hughes.



www.dresserutility.com

RCS Sure 150 IOM Manual NGS.IPG.0042a

08.21