

P-101
Rev. G
Type S Flowmeter Parts List:
5/8" – 2" Type S Flowmeters

Sold & Serviced By:
Don Johns, Inc.
701 N. Raddant Rd.
Batavia, IL 60510
(630) 454-4700
www.donjohns.com

RED SEAL
MEASUREMENT

Parts List for **neptune** Type S Flowmeters



5/8" and 3/4" Type S Flowmeters with 100 and 600 Series Register and Internal Gear Train

100 Series

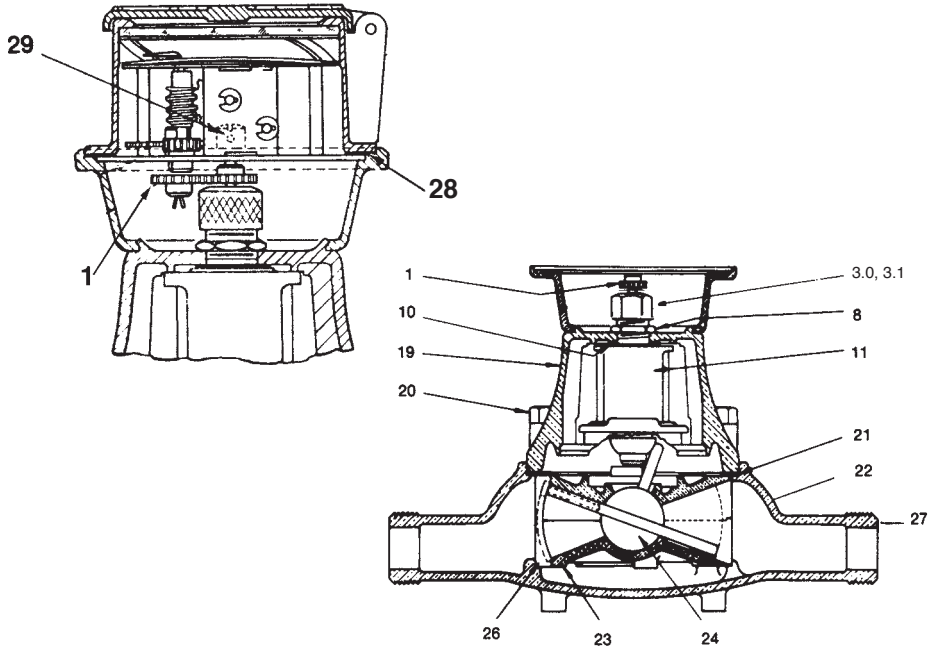

600 Series

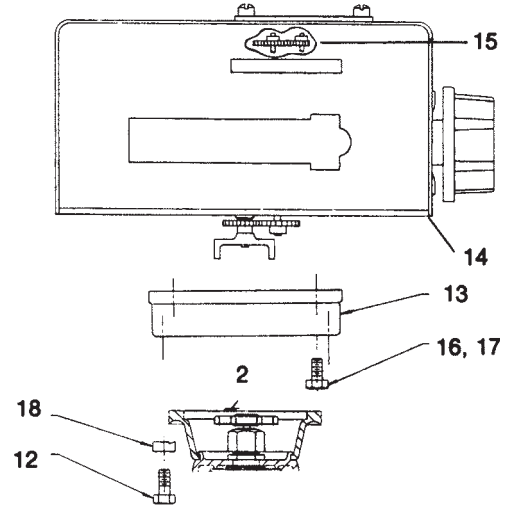

Item	Part	Part Numbers	
		5/8"	3/4"
1	Change Gear, Stuffing Box (give dia. & no. teeth) (100 Series)	See Form TSG 310	See Form TSG 310
2	Star Connection	82976-001	82976-001
3.0	Nut, Stuffing Box (100 Series)	6217-000	6217-000
3.1	O-Ring (100 Series) Viton	85210-003	85210-003
4	Stuffing Box Nut and Bushing (600 Series)	83536-000	83536-000
5	Seal, U-Cup	100025-004	100025-004
6	Expander, Seal	83539-000	83539-000
7	Spring, Stuffing Box	83540-000	83540-000
8	Nut, Gear Train Clamp	34-000	34-000
9	Gasket O-ring — 1/16 Dia. x 5/8 (600 Series)	100138-012	100138-012
10	Gasket Gear Train (lead) (100 Series)	4859-002	4859-002
11	Gear Train Complete	See Page 5	See Page 5
12	Screw — 1/4-20 UNC	100059-024	100059-024
13	Adapter	100729-001	100729-001
14	600 Series Register	100498-XXX	100498-XXX
15	Change Gears (600 Series Register)	See Form TSG310	See Form TSG310
16	Screw — 1/4-28 x 1/2	100061-023	100061-023
17	Screw, Drilled — 1/4-28 x 1/2 Drill	100062-023	100062-023
18	Screw, Sleeve	100737-001	100737-001
19	Main Case, Upper		
	Mod. 157 Cup	244-021	244-019
	Mod. 600 Cup	244-031	244-025
20	Bolt, Main Case — 7/16-14 x 1-1/8	100071-055	100071-055
21	Gasket, Main Case Klingersil	4858-012	4861-013
22	Main Case, Lower	246-032	5364-004
23	Measuring Chamber Complete w/Fiber Disc	285-129	312-080
24	Disc Piston Complete (Fiber)	309-046	310-031
26	Channel, Thrust Roller (plastic)	100288-001	100292-001
27	Couplings	105-038	167-042
28	Gasket, Register Box Seat	335-002	335-002
29	Screw — 10-32 x .50	9287-016	9287-016

Detail Stuffing Box (600 Series)

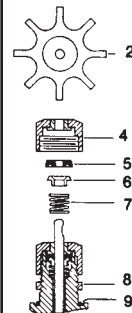

1" Type S Flowmeters with 100, 600, and 800 Series Register and Internal Gear Train

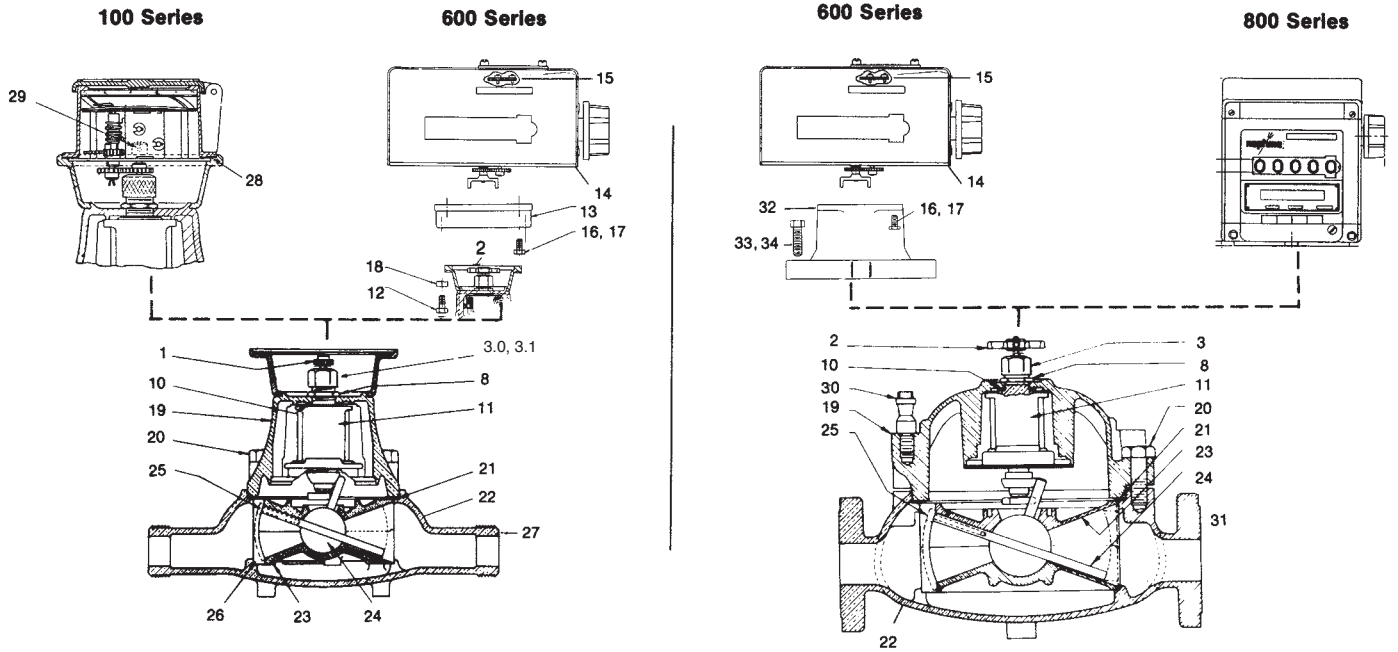

Item	Part	Part Number	
		1" Screw End	1" Flanged
1	Change Gear, Stuffing Box (give dia. & No. teeth) (100 Series)	See Form TSG 310	See Form TSG 310
2	Star Connection	82976-001	82976-001
3.0	Nut, Stuffing Box	6217-000	6217-000
3.1	O-Ring (100 Series) Viton	85210-003	85210-003
4	Stuffing Box Nut and Bushing	83536-000	83536-000
5	Seal, U-Cup	100025-004	100025-004
6	Expanding, Seal	83539-000	83539-000
7	Spring, Stuffing Box	83540-000	83540-000
8	Nut, Gear Train Clamp	34-000	34-000
9	Gasket, O-ring (600 & 800 Series) — 1/16 Dia. x 5/8 ID	100138-012	100138-012
10	Gasket Gear Train (lead) (100 Series)	4859-002	-----
11	Gear Train Complete	See Page 5	See Page 5
12	Screw — 1/4-20 UNC	100059-024	-----
13	Adapter	100729-001	-----
14	600 Series Register	100498-XXX	100498-XXX
15	Change Gears (600 & 800 Series Register)	See Form TSG 310	See Form TSG 310
16	Screw, Hex HD 1/4-28 x 1/2	100061-023	-----
17	Screw, Hex HD 1/4-28 x 1/2 Drilled	100062-023	-----
18	Screw, Sleeve	100737-001	-----
19	Main Case, Upper		84798-000
	Mod. 157 Cup	2200-008	-----
	Mod. 600 Cup	2200-015	-----
20	Bolt, Main Case	100071-055	100071-042
21	Gasket, Main Case Klingersil	4862-012	4862-012
22	Main Case, Lower (use without Auto Stop Valve)	2423-001	80670-001
	Main Case, Lower (use with Auto Stop Valve)	-----	80670-002
23	Measuring Chamber Complete with Disc	286-147	286-147
24	Disc Piston Complete (Fiber) — 1"	311-034	311-034
25	Roller, Thrust	190-010	190-010
26	Channel, Thrust Roller (Plastic)	100298-001	100298-001
27	Couplings	212-050	-----
28	Gasket, Register Box Seat	335-002	-----
29	Screw — 10-32 x .50	9287-016	-----
30	Stud, Register Mounting (800 Series Reg.)	-----	84435-000
31	Flange Gasket	-----	1312-010
32	Adapter, for mounting 600 Series Reg.	-----	100484-001
33	Screw, Hex HD 3/8-16 UNC	-----	100067-051
34	Screw, Hex HD 3/8-16 x 1-1/4, Drilled	-----	100068-050
35	Bird Cage Adapter (800 Series Register) not shown	-----	85251-000

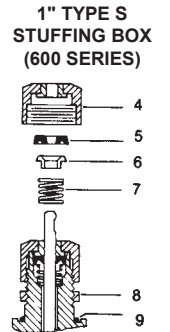

1 1/2" and 2" Type S Flowmeters with 100, 600, and 800 Series Registers and External Gear Train

(For Magnetic Drive Version of 1-1/2" & 2" Type S, See Form P106. Form P106 replaces Form P120.)

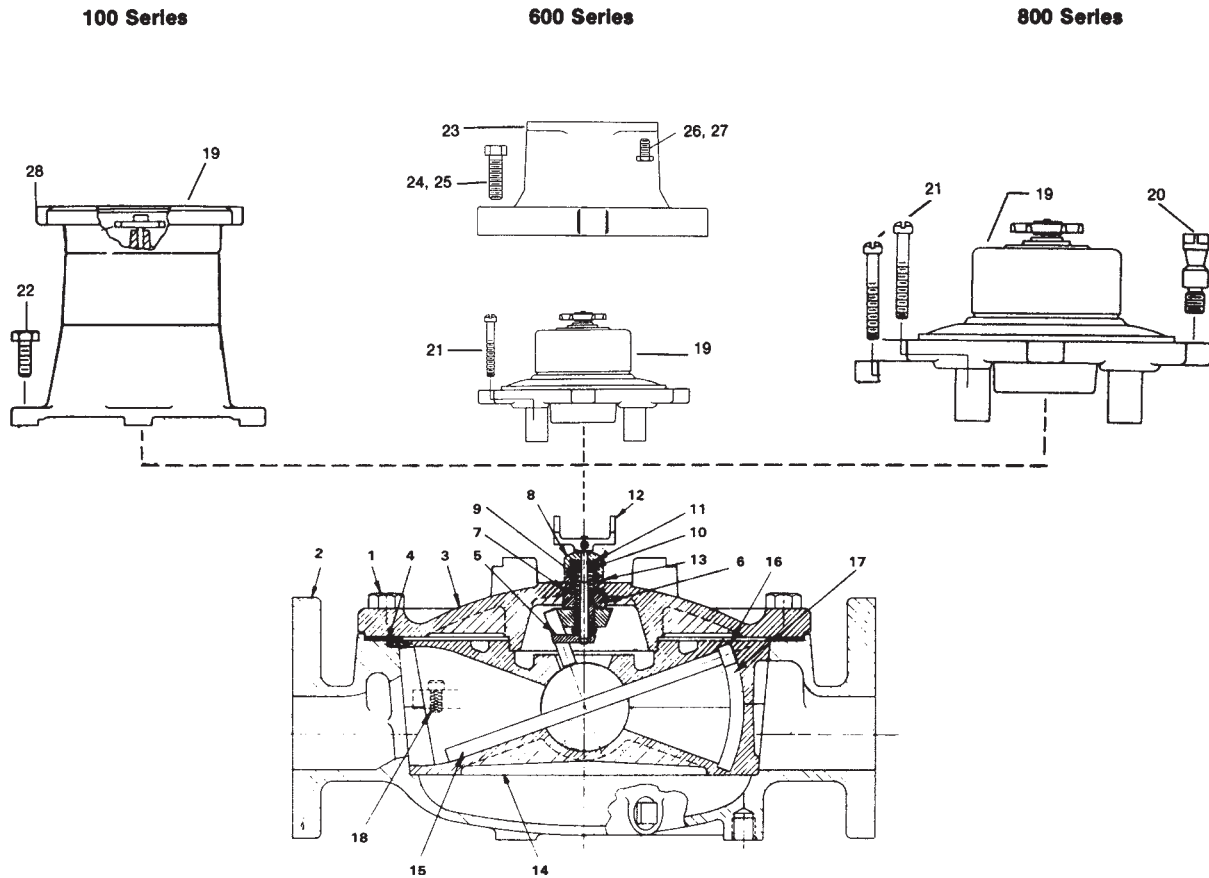

Index	Part	Part Number	
		1-1/2"	2"
1	Bolt, Main Case — 7/16-14 x 11	100071-042	100071-042
2	Main Case w/Drain Plug	4887-007	4890-008
3	Cover, Main Case (Complete)	100151-001	100150-001
4	Gasket, Main Case Klingersil	4863-008	4864-011
5	Spindle Assy	100178-001	100178-001
6	Housing, Roller Assy	86141-002	86141-001
7	Gasket, O-ring — 3/32 Dia. Viton	100146-004	100146-004
8	Stuffing Box Nut w/Bushing	83536-000	83536-000
9	Spring, Stuffing Box	86150-001	86150-001
10	Expander, Seal	83539-001	83539-001
11	Seal, U-cup Shaft	100025-004	100025-004
12	Drive Fork Assy	82592-002	82592-002
13	Nut, Clamp	34-000	34-000
14	Measuring Chamber w/Ryton Disc	788-143	818-137
15	Disc Piston Complete (Ryton)	1410-040	1416-043
16	Roller, Thrust	787-014	817-015
17	Bearing Plate, Thrust Roller	1994-008	1995-007
18	Screw, Chamber Assembling — 1/4-28 UNF-2A FIL HD 5/8	8302-111	8302-111
19	Gear Train and Adapter Assy	See Page 5	See Page 5
20	Stud, Register Mounting	84435-000	84435-000
21	Screw, 1/4-28 x 1-3/4 fil. hd.	86157-000	86157-000
22	Screw, Hex HD 1/4-28 x 3/4	100061-025	100061-025
23	Adapter for 600 Series Reg.	100484-001	100484-001
24	Screw, Hex HD 3/8-16 UNC	100067-051	100067-051
25	Screw, Hex HD 3/8-16 x 1-1/4, Drilled	100068-050	100068-050
26	Screw, Hex HD 1/4-28 x 1/2	100061-023	100061-023
27	Screw, Hex HD 1/4-28 x 1/2, Drilled	100062-023	100062-023
28	Screw — 10-32 x .50	9287-016	9287-016

Typical Gear Trains Type S Flowmeters

5/8" Type S Industrial Flowmeter

Type Register	Test Hand	Gear Train		Enclosed Type
		Reduction	Open Type	
157	1 USG	64	N/A	67-068
	10 USG	256	N/A	67-074
	10 Pounds	64	N/A	67-068
	10 Liters	256	N/A	67-074
106 or 111	10 USG	256	N/A	67-074
	10 Pounds	16	N/A	67-191
	10 Liters	64	N/A	67-068
	1 USG	60	N/A	67-377
600 Series	10 Pounds	60	N/A	67-377
	10 Liters	113.4	N/A	67-385
	1 USG			

3/4" Type S Industrial Flowmeter

Type Register	Test Hand	Gear Train		Enclosed Type
		Reduction	Open Type	
157	1 USG	68	N/A	67-376
	10 USG	256	N/A	67-074
	10 Pounds	64	N/A	67-068
	10 Liters	68	N/A	67-376
106 or 111*	1 USG	16	N/A	67-191
	10 USG	68	N/A	67-376
	10 Pounds	17.53	N/A	N/A
	10 Liters	16	N/A	67-191
600 Series	1 USG	36.4	N/A	67-381
	10 Pounds	36.4	N/A	67-381
	10 Liters	116.875	N/A	67-378
	10 Kilos	116.875	N/A	67-378

1" Type S Industrial Flowmeter

Type Register	Test Hand	Gear Train		Enclosed Type
		Reduction	Open Type	
157	1 USG	16	N/A	67-191
	10 USG	256	N/A	67-074
	10 Pounds	16	N/A	67-191
	10 Liters	64	N/A	67-068
106-111*	1 USG	8	N/A	67-265
	10 USG	64	N/A	67-068
	10 Pounds	8	N/A	67-265
	10 Liters	16	N/A	67-191
600 Series	1 USG	13.29	N/A	67-379
	10 Pounds	13.29	N/A	67-379
	10 Liters	36.4	N/A	67-381
	1 USG	11.14	82886-050	82886-003
800 Series	10 Pounds	14.06	N/A	82886-025
	10 Liters	28.36	N/A	82886-006

1-1/2" Type S Industrial Flowmeter

Type Register	Test Hand	Gear Train		Enclosed Type	External
		Reduction	Open Type		
157	10 USG	64	N/A	N/A	86974-000
	100 USG	256	N/A	N/A	86974-001
	10 Pounds	6.075	N/A	N/A	N/A
	10 Pounds	5.04	N/A	N/A	86974-002
600 Series	10 Liters	14.06	N/A	N/A	86974-011
	1 USG	4.25	N/A	N/A	86158-001
	10 Pounds	5.04	N/A	N/A	86158-002
	10 Liters	10.875	N/A	N/A	86158-003
800 Series	1 USG	4.25	N/A	82892-008	86158-001
	10 Pounds	5.04	N/A	82892-009	86158-002
	10 Liters	10.875	N/A	82892-012	86158-003

2" Type S Industrial Flowmeter

Type Register	Test Hand	Gear Train		Enclosed Type	External
		Reduction	Open Type		
157	10 USG	64	N/A	N/A	86974-000
	10 USG	20.68	N/A	N/A	86974-006
	100 USG	240	N/A	N/A	86974-009
	10 Pounds	2.75	N/A	N/A	N/A
600 Series	10 Pounds	4.25	N/A	N/A	86974-003
	10 Deca-Liters	64	N/A	N/A	86974-000
	1 USG	2.336	N/A	N/A	86158-004
	10 Pounds	2.75	N/A	N/A	86158-000
800 Series	10 Liters	5.85	N/A	N/A	86158-005
	1 USG	2.336	N/A	82890-003	86158-004
	10 Pounds	2.75	N/A	82890-007	86158-000
	10 Liters	5.85	N/A	82890-008	86158-005

Note: For units of registration not listed above, please refer to Form TSG-101.

* Register Models 106 and 111 have been obsoleted; however, gear trains for these meters are still available.

Sold & Serviced By:

**Don Johns, Inc.
701 N. Raddant Rd.
Batavia, IL 6-510
(63) 454-4700
www.donjohns.com**

© 2011

Specifications subject to change without prior notification.

**RED SEAL
MEASUREMENT**