



OPTISWIRL 2100 Handbook

Vortex flowmeter

Electronic revision: up to ER 1.0.2_

All rights reserved. It is prohibited to reproduce this documentation, or any part thereof, without the prior written authorisation of KROHNE Messtechnik GmbH.

Subject to change without notice.

Copyright 2023 by
KROHNE Messtechnik GmbH - Ludwig-Krohne-Str. 5 - 47058 Duisburg (Germany)

1	Safety instructions	6
1.1	Software history	6
1.2	Intended use	7
1.3	Conformity	9
1.4	Pressure equipment directive.....	10
1.5	Safety instructions from the manufacturer	11
1.5.1	Copyright and data protection	11
1.5.2	Disclaimer	11
1.5.3	Product liability and warranty	12
1.5.4	Information concerning the documentation.....	12
1.5.5	Warnings and symbols used.....	13
1.6	Safety instructions for the operator.....	13
2	Device description	14
2.1	Scope of delivery.....	14
2.2	Device versions.....	14
2.2.1	Devices in flange and sandwich version.....	15
2.2.2	Remote version	15
2.2.3	Devices with integrated nominal diameter reduction.....	16
2.2.4	Dual seal	17
2.3	Nameplate	18
3	Installation	20
3.1	General notes on installation	20
3.2	Storage	20
3.3	Transport	20
3.4	Installation conditions	21
3.4.1	Installation when measuring liquids	22
3.4.2	Installation when measuring steam and gases	24
3.4.3	Pipelines with control valve	25
3.4.4	Preferred mounting position	25
3.5	Minimum inlet sections	26
3.6	Minimum outlet sections.....	27
3.7	Flow straightener	27
3.8	Installation	28
3.8.1	General installation notes.....	28
3.8.2	Installing devices in sandwich design	29
3.8.3	Installing devices in flange design	30
3.8.4	Mounting the field housing, remote version	31
3.9	Heat insulation.....	32
3.10	Turning the connection housing.....	33
3.11	Turning the display	34
3.12	Weather protection cover (optional).....	35

4	Electrical connections	36
<hr/>		
4.1	Safety instructions.....	36
4.2	Connecting the signal converter	37
4.3	Electrical connections	38
4.3.1	Power supply.....	38
4.3.2	Current output	38
4.3.3	Pulse output	39
4.4	Connection of remote version	41
4.5	Grounding connections.....	43
4.6	Ingress protection	44
5	Start-up	45
<hr/>		
5.1	Start-up screen	45
5.2	Operation	45
6	Operation	46
<hr/>		
6.1	Display and operating elements	46
6.1.1	Display for selection of submenu and functions in menu mode.....	47
6.1.2	Display when setting a parameter in parameter and data mode	48
6.1.3	Display for selection of submenu and functions with preview.....	48
6.2	Basic principles of operation.....	49
6.2.1	Functional description of the keys.....	49
6.2.2	Switch from measuring mode to menu mode.....	49
6.2.3	Change the settings in the menu.....	49
6.2.4	Character selection in change mode.....	50
6.2.5	Units, figures and factors	51
6.2.6	Security and permissions	52
6.3	Overview of the most important functions and units.....	53
6.4	Menu languages	53
6.5	Units.....	54
6.6	Menu structure	57
6.6.1	Menu overview "A Quick Setup".....	57
6.6.2	Menu overview "B Test"	58
6.6.3	Menu overview "C Setup".....	58
6.6.4	Menu description "A Quick Setup".....	61
6.6.5	Menu description "B Test"	64
6.6.6	Menu description "C Setup".....	65
6.7	Status messages and diagnostic information.....	70
6.8	A12 plausibility checks	75
7	Service	76
<hr/>		
7.1	Replacing the signal converter / LC display	76
7.2	Maintaining the O-rings.....	77
7.3	Spare parts availability.....	78
7.4	Availability of services	78

7.5	Returning the device to the manufacturer.....	78
7.5.1	General information.....	78
7.5.2	Form (for copying) to accompany a returned device.....	79
7.6	Disposal.....	79
7.7	Disassembly and recycling.....	80
7.7.1	Disassembly of the compact signal converter unit.....	82
7.7.2	Disassembly of the remote signal converter unit.....	83
8	Technical data.....	85
<hr/>		
8.1	Functional principle.....	85
8.2	Technical data.....	86
8.3	Dimensions and weights.....	91
8.3.1	Flange versions.....	91
8.3.2	Sandwich versions.....	96
8.3.3	Remote versions.....	97
8.4	Flow tables.....	98
9	Notes.....	101
<hr/>		

1.1 Software history

The "Electronic Revision" (ER) is consulted to document the revision status of electronic equipment according to NE 53 for all devices. It is easy to see from the ER whether troubleshooting or larger changes in the electronic equipment have taken place and how that has affected the compatibility.

1	Downwards compatible changes and fault repair with no effect on operation (e.g. spelling mistakes on display)	
2- _	Downwards compatible hardware and/or software change of interfaces:	
	H	HART®
3- _	Downwards compatible hardware and/or software change of inputs and outputs:	
	CO	Current output
	PO	Pulse output
	D	Display
4	Downwards compatible changes with new functions	
5	Incompatible changes, i.e. electronic equipment must be changed	

Table 1-1: Description of changes

Release date	Electronic revision	Changes and compatibility	Documentation
03/2020	ER 1.0.0_	-	MA OPTISWIRL 2100 R01, R02
03/2021	ER 1.0.1_	1	MA OPTISWIRL 2100 R03
07/2023	ER 1.0.2_	3-D	MA OPTISWIRL 2100 R04

Table 1-2: Changes and effect on compatibility

1.2 Intended use

**CAUTION!**

Responsibility for the use of the measuring devices with regard to suitability, intended use and corrosion resistance of the used materials against the measured fluid lies solely with the operator.

**INFORMATION!**

This device is a Group 1, Class A device as specified within CISPR11. It is intended for use in industrial environment. There may be potential difficulties in ensuring electromagnetic compatibility in other environments, due to conducted as well as radiated disturbances.

**INFORMATION!**

The manufacturer is not liable for any damage resulting from improper use or use for other than the intended purpose.

The vortex flowmeters are used for flow measurement of gases, vapours and liquids.

The devices are particularly suitable for the measurement of:

- Clean liquids with low viscosity (< 10 cP)
- Hydrocarbons with low viscosity (< 10 cP)
- Water
- Chemicals with low corrosiveness
- Saturated steam
- Superheated steam, including CIP (Cleaning in Place) and SIP (Sterilising in Place) applications in the food industry

Note the following:

- In your project planning, please observe the data given in the corrosion tables.
- The pressure-bearing parts have been designed and rated for stationary operation taking into account the maximum pressure and temperature.
- Observe the data indicated on the nameplate for PS (stated pressures), TS (stated temperatures) and PT (test pressure).
- External forces and moments, caused e.g. by pipe stresses, have not been taken into account.

Primarily, volumetric flow is measured. A fixed density can be programmed to the measuring device. From this parameter the measuring device calculates the mass flow or standard volumetric flow using pre-programmed density data and then exports the measured values via various communication interfaces.

The devices are rated for the following flow velocities:

Liquids: DN15...DN300		V_{\min} : 0.3 m/s	0.98 ft/s	$V_{\min} [\text{m/s}] = 0.5 \times \sqrt{\frac{998}{\rho}} \quad \rho \left[\frac{\text{kg}}{\text{m}^3} \right]$	①
		V_{\max} : 10 m/s	32 ft/s	$V_{\max} [\text{m/s}] = 7 \times \left(\frac{998}{\rho} \right)^{0.47} \quad \rho \left[\frac{\text{kg}}{\text{m}^3} \right]$	②
Gases and steam:	DN15	V_{\min} : 3 m/s	10 ft/s	$V_{\min} [\text{m/s}] = 6 \times \sqrt{\frac{1.204}{\rho}} \quad \rho \left[\frac{\text{kg}}{\text{m}^3} \right]$	①
		V_{\max} : 45 m/s	147 ft/s	$V_{\max} [\text{m/s}] = 7 \times \left(\frac{998}{\rho} \right)^{0.47} \quad \rho \left[\frac{\text{kg}}{\text{m}^3} \right]$	②
	DN15C	V_{\min} : 3 m/s	10 ft/s	$V_{\min} [\text{m/s}] = 12 \times \sqrt{\frac{1.204}{\rho}} \quad \rho \left[\frac{\text{kg}}{\text{m}^3} \right]$	①
		V_{\max} : 55 m/s	180 ft/s	$V_{\max} [\text{m/s}] = 7 \times \left(\frac{998}{\rho} \right)^{0.47} \quad \rho \left[\frac{\text{kg}}{\text{m}^3} \right]$	②
	DN25	V_{\min} : 2 m/s	6.6 ft/s	$V_{\min} [\text{m/s}] = 6 \times \sqrt{\frac{1.204}{\rho}} \quad \rho \left[\frac{\text{kg}}{\text{m}^3} \right]$	①
		V_{\max} : 70 m/s	229 ft/s	$V_{\max} [\text{m/s}] = 7 \times \left(\frac{998}{\rho} \right)^{0.47} \quad \rho \left[\frac{\text{kg}}{\text{m}^3} \right]$	②
	DN25C	V_{\min} : 2 m/s	6.6 ft/s	$V_{\min} [\text{m/s}] = 12 \times \sqrt{\frac{1.204}{\rho}} \quad \rho \left[\frac{\text{kg}}{\text{m}^3} \right]$	①
		V_{\max} : 80 m/s	262 ft/s	$V_{\max} [\text{m/s}] = 7 \times \left(\frac{998}{\rho} \right)^{0.47} \quad \rho \left[\frac{\text{kg}}{\text{m}^3} \right]$	②
	DN40... DN300	V_{\min} : 2 m/s	6.6 ft/s	$V_{\min} [\text{m/s}] = 6 \times \sqrt{\frac{1.204}{\rho}} \quad \rho \left[\frac{\text{kg}}{\text{m}^3} \right]$	①
		V_{\max} : 80 m/s	262 ft/s	$V_{\max} [\text{m/s}] = 7 \times \left(\frac{998}{\rho} \right)^{0.47} \quad \rho \left[\frac{\text{kg}}{\text{m}^3} \right]$	②

Table 1-3: Flow velocities

- ① Use the larger value, according to the amount.
- ② Use the smaller value, according to the amount.



INFORMATION!

DN15C and DN25C have a robust flow sensor (signal pick-up) for harsh measuring conditions and higher maximum velocity compared to the standard version.

1.3 Conformity

The manufacturer certifies successful testing of the product by applying the conformity mark on the device.

This device fulfils the statutory requirements of the relevant directives and regulations.

For further information on directives, regulations, standards and certifications, please refer to the declaration of conformity which you can download from the manufacturer's website.



DANGER!

For devices used in hazardous areas, additional safety notes apply; please refer to the Ex documentation.

1.4 Pressure equipment directive

A conformity assessment in accordance with pressure equipment directive has been carried out for the devices described. Conformity is certified by applying the conformity mark. The number of the notified body is also stated.

The PED key describes the rating of the devices:

Example: PED/G1/III/H	
G	Gases and vapours
1	Fluid group 1
III	Category III
H	Conformity assessment method according to Module H

Table 1-4: Example of PED key

The PED key identification can be found on the nameplate of the device (for details refer to *Nameplate* on page 18).



INFORMATION!

The stated pressures (PS) and temperatures (TS) only apply as refers to the pressure resistance of the sensor body. As regards the functionality of the entire device, further restrictions of the maximum temperature may need to be observed (e.g. ATEX approval). Devices rated below category I due to their size, do not receive the conformity mark in the scope of the PED. These devices are subject to applicable sound engineering practice (SEP).

Residual risk

A risk analysis in accordance with the pressure equipment directive has been carried out for the devices. The residual risk is described as follows:

- The devices are designed according to the valid and applicable rules and standards for static operation and their pressure resistance is calculated for the declared maximum pressure and temperature (no calculation for cyclical change).
- Responsibility for the use of the measuring devices with regard to corrosion resistance of the used materials against the measured fluid lies solely with the operator.
- Don't use abrasive and high viscous media.
- Avoid pulsation and cavitation.
- The maximum allowable ambient temperatures are depending on the device equipment and declared in the technical data.
- The draining of the device will be performed in the same way as the connected pipeline.
- Protect devices from vibration and high-frequency oscillation.
- Implement appropriate measures to counteract external fire hazards

1.5 Safety instructions from the manufacturer

1.5.1 Copyright and data protection

The contents of this document have been created with great care. Nevertheless, we provide no guarantee that the contents are correct, complete or up-to-date.

The contents and works in this document are subject to copyright. Contributions from third parties are identified as such. Reproduction, processing, dissemination and any type of use beyond what is permitted under copyright requires written authorisation from the respective author and/or the manufacturer.

The manufacturer tries always to observe the copyrights of others, and to draw on works created in-house or works in the public domain.

The collection of personal data (such as names, street addresses or e-mail addresses) in the manufacturer's documents is always on a voluntary basis whenever possible. Whenever feasible, it is always possible to make use of the offerings and services without providing any personal data.

We draw your attention to the fact that data transmission over the Internet (e.g. when communicating by e-mail) may involve gaps in security. It is not possible to protect such data completely against access by third parties.

We hereby expressly prohibit the use of the contact data published as part of our duty to publish an imprint for the purpose of sending us any advertising or informational materials that we have not expressly requested.

1.5.2 Disclaimer

The manufacturer will not be liable for any damage of any kind by using its product, including, but not limited to direct, indirect or incidental and consequential damages.

This disclaimer does not apply in case the manufacturer has acted on purpose or with gross negligence. In the event any applicable law does not allow such limitations on implied warranties or the exclusion of limitation of certain damages, you may, if such law applies to you, not be subject to some or all of the above disclaimer, exclusions or limitations.

Any product purchased from the manufacturer is warranted in accordance with the relevant product documentation and our Terms and Conditions of Sale.

The manufacturer reserves the right to alter the content of its documents, including this disclaimer in any way, at any time, for any reason, without prior notification, and will not be liable in any way for possible consequences of such changes.

1.5.3 Product liability and warranty

The operator shall bear responsibility for the suitability of the device for the specific purpose. The manufacturer accepts no liability for the consequences of misuse by the operator. Improper installation or operation of the devices (systems) will cause the warranty to be void. The respective "Standard Terms and Conditions" which form the basis for the sales contract shall also apply.

1.5.4 Information concerning the documentation

To prevent any injury to the user or damage to the device it is essential that you read the information in this document and observe applicable national standards, safety requirements and accident prevention regulations.

If this document is not in your native language and if you have any problems understanding the text, we advise you to contact your local office for assistance. The manufacturer cannot accept responsibility for any damage or injury caused by misunderstanding of the information in this document.

This document is provided to help you establish operating conditions, which will permit safe and efficient use of this device. Special considerations and precautions are also described in the document, which appear in the form of icons as shown below.

1.5.5 Warnings and symbols used

Safety warnings are indicated by the following symbols.



DANGER!

This warning refers to the immediate danger when working with electricity.



DANGER!

This warning refers to the immediate danger of burns caused by heat or hot surfaces.



DANGER!

This warning refers to the immediate danger when using this device in a hazardous atmosphere.



DANGER!

These warnings must be observed without fail. Even partial disregard of this warning can lead to serious health problems and even death. There is also the risk of seriously damaging the device or parts of the operator's plant.



WARNING!

Disregarding this safety warning, even if only in part, poses the risk of serious health problems. There is also the risk of damaging the device or parts of the operator's plant.



CAUTION!

Disregarding these instructions can result in damage to the device or to parts of the operator's plant.



INFORMATION!

These instructions contain important information for the handling of the device.



LEGAL NOTICE!

This note contains information on statutory directives and standards.



• **HANDLING**

This symbol designates all instructions for actions to be carried out by the operator in the specified sequence.

➔ **RESULT**

This symbol refers to all important consequences of the previous actions.

1.6 Safety instructions for the operator



WARNING!

*In general, devices from the manufacturer may only be installed, commissioned, operated and maintained by properly trained and authorized personnel.
This document is provided to help you establish operating conditions, which will permit safe and efficient use of this device.*

2.1 Scope of delivery



INFORMATION!

Inspect the packaging carefully for damages or signs of rough handling. Report damage to the carrier and to the local office of the manufacturer.



INFORMATION!

Do a check of the packing list to make sure that you have all the elements given in the order.



INFORMATION!

Look at the device nameplate to ensure that the device is delivered according to your order. Check for the correct supply voltage printed on the nameplate.

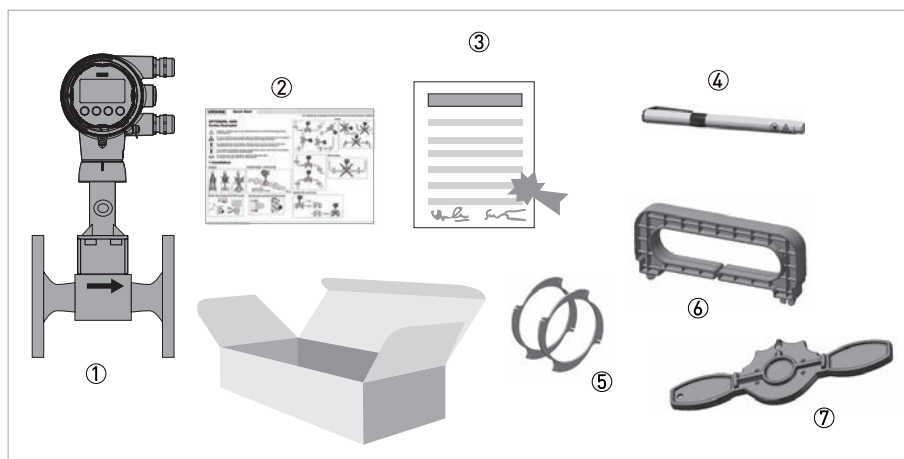

Figure 2-1: Scope of delivery

- ① Measuring device in ordered version
- ② Product documentation
- ③ Certificates, calibration report (optional) and parameter data sheet
- ④ Bar magnet
- ⑤ Centering rings (only for sandwich devices)
- ⑥ Handle to pull off the display
- ⑦ Key for opening the front and rear cover

2.2 Device versions

The devices are delivered in the following variants:

- Signal converter with display
- Flow sensor in flanged design, flow sensor F
- Flow sensor in sandwich design, flow sensor S
- Remote version - flow sensor with separated remote signal converter

2.2.1 Devices in flange and sandwich version

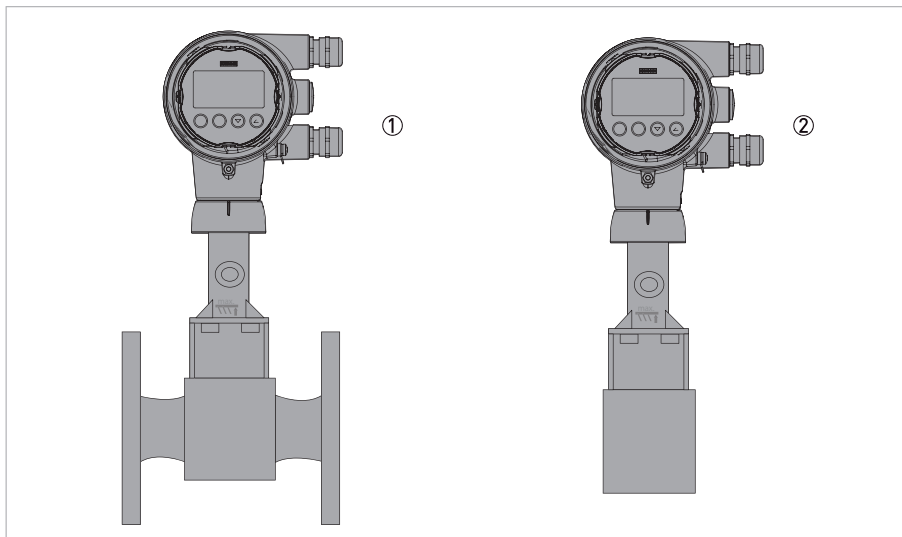

Figure 2-2: Available versions

- ① Flange version
- ② Sandwich version

The sandwich version has 2 centering rings to aid with the installation.

2.2.2 Remote version

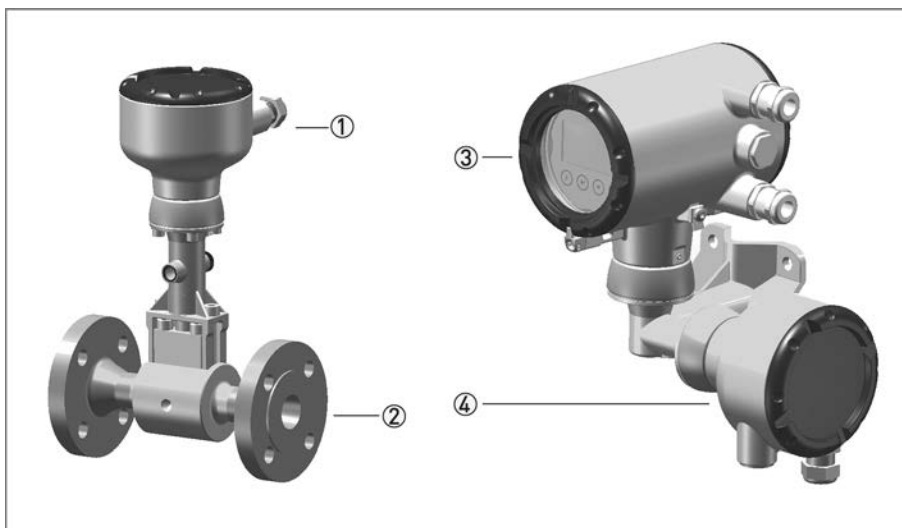

Figure 2-3: Remote version

- ① Flow sensor connection box
- ② Flow sensor
- ③ Signal converter
- ④ Wall mount bracket connection box

With the remote version, the flow sensor and signal converter are installed separately in different places. The 6-pin, shielded connection cable is available with a length up to 50 m / 164 ft.

2.2.3 Devices with integrated nominal diameter reduction

The device versions F1R and F2R offer an integrated nominal diameter reduction up to two nominal diameter sizes to assure best results in accuracy and optimum measuring ranges; even in pipelines with large diameters, which have been designed for a low pressure loss.

Nominal diameter of flow sensor	Nominal size of process connections									
	DN15	DN25	DN40	DN50	DN80	DN100	DN150	DN200	DN250	DN300
DN15	StV ①	F1R	F2R	-	-	-	-	-	-	-
DN25	-	StV ①	F1R	F2R	-	-	-	-	-	-
DN40	-	-	StV ①	F1R	F2R	-	-	-	-	-
DN50	-	-	-	StV ①	F1R	F2R	-	-	-	-
DN80	-	-	-	-	StV ①	F1R	F2R	-	-	-
DN100	-	-	-	-	-	StV ①	F1R	F2R	-	-
DN150	-	-	-	-	-	-	StV ①	F1R	F2R	-
DN200	-	-	-	-	-	-	-	StV ①	F1R	F2R
DN250	-	-	-	-	-	-	-	-	StV ①	F1R
DN300	-	-	-	-	-	-	-	-	-	StV ①

Table 2-1: Integrated nominal diameter reduction

① Standard version

2.2.4 Dual seal

To comply with the requirements of ANSI/ISA 12.27.01 "Requirements for Process Sealing Between Electrical Systems and Flammable or Combustible Process Fluids", a membrane vent is integrated in the neck of the device. This vent is located between the primary seal (process) and the secondary seal (electronics compartment) and works to prevent pressure build-up in the device neck, thus preventing product from penetrating the electronics compartment in the unlikely event of a leak in the primary seal.

The seal between the pick-up and the measuring tube is considered as the primary seal. The material used for this is always the same as that used for the measuring tube itself (e.g. 1.4435 / 316L for measuring tube made of stainless steel 1.4404 / 316L). When selecting the material, corrosion resistance depending on process parameters (product, temperature) must be taken into account.

- It protects the electronics from the process media.
- Any leak in the primary seal can be detected.

Even though there is no reason to expect the seal to fail, regular visual checks should still be carried out to detect any possible leak as early as possible.

In the event of a leak, contact the manufacturer's service department to service or replace the device.

2.3 Nameplate



INFORMATION!

Look at the device nameplate to ensure that the device is delivered according to your order. Check for the correct supply voltage printed on the nameplate.

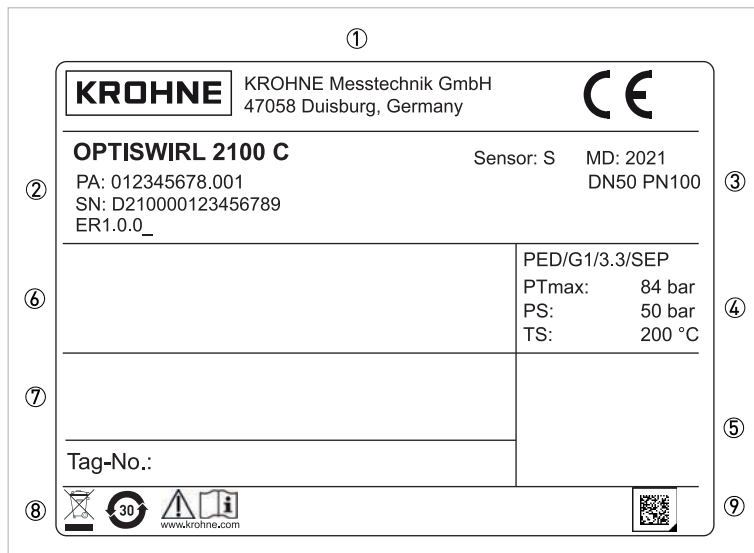

Figure 2-4: Example of a nameplate for the compact version

- ① Manufacturer address
- ② Product designation, production order number, serial number and electronic revision (ER)
- ③ Manufacturing year and process data
- ④ PED data
- ⑤ Fluid data
- ⑥ Ex data according to notified body (if applicable)
- ⑦ Electrical connection data
- ⑧ Disposal, China RoHs marking and safety instructions
- ⑨ Data Matrix code

Auto ID according to DIN specifications

The auto ID code (data matrix) guides you directly to the PICK server (Product Information Center KROHNE).

Scan the auto ID code on the device nameplate to download all product specific information.

- Handbooks, Quick Starts and Supplementary instructions
- Calibration certificates
- Parameter data sheets
- Digital nameplates

3.1 General notes on installation



INFORMATION!

Inspect the packaging carefully for damages or signs of rough handling. Report damage to the carrier and to the local office of the manufacturer.



INFORMATION!

Do a check of the packing list to make sure that you have all the elements given in the order.

3.2 Storage

- Store the device in a dry, dust-free location.
- Avoid extended direct exposure to the sun.
- Store the device in the original packaging.
- The permissible storage temperature for standard devices is $-40\dots+85^{\circ}\text{C}$ / $-40\dots+185^{\circ}\text{F}$.

3.3 Transport

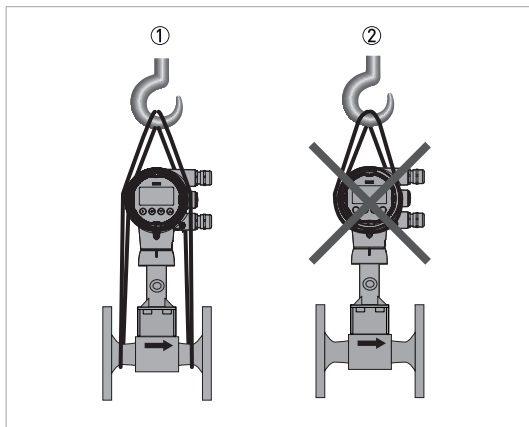

Figure 3-1: Transport instructions

- ① Use lifting straps wrapped around both process connections for transport
- ② Do not lift measuring devices by the signal converter housing for transport



CAUTION!

Do not use lifting chains as they may damage the housing.



CAUTION!

Non-secured devices can pose risk of injury. The centre of mass of the device is often higher than the point at which the lifting straps are attached. Prevent the measuring device from sliding or rotating accidentally.

3.4 Installation conditions

**INFORMATION!**

For accurate volumetric flow measurement the measuring device needs a completely filled pipe and a fully developed flow profile.

**CAUTION!**

Any vibrations may distort the measuring result. That is why any vibrations in the pipeline must be prevented through suitable measures.

**CAUTION!****Procedures to carry out before installing the device:**

- *Nominal diameter of connection pipe flange = nominal flange diameter of pipe!*
- *Use flanges with smooth holes, e.g. welding neck flanges.*
- *Align carefully the holes of the connecting flange and the flowmeter flange.*
- *Check the compatibility of the gasket material with the process product.*
- *Make sure that the gaskets are arranged concentrically. The flange gaskets must not project into the pipe cross-section.*
- *The flanges have to be concentric.*
- *There must not be any pipe bends, valves, flaps or other internals in the immediate inlet run.*
- *Devices in sandwich version may only be installed using centering rings.*
- *Never install the device directly behind piston compressors or rotary piston meters.*
- *The device must not be heated by radiated heat (e.g. exposure to the sun) to an electronics housing surface temperature above the maximum permissible ambient temperature. If it is necessary to prevent damage from heat sources, a heat protection (e.g. sun shade) has to be installed.*
- *Do not lay signal cables directly next to cables for the power supply.*
- *At product temperatures or ambient temperatures $>+65^{\circ}\text{C}$ / $+149^{\circ}\text{F}$, a connection cable and cable glands with a minimum service temperature of $+80^{\circ}\text{C}$ / $+176^{\circ}\text{F}$ must be used.*

**INFORMATION!**

If there is a risk of water hammers in steam networks, appropriate condensate separators must be installed. Suitable measures must be taken to avoid water cavitation if it is a possible risk.

3.4.1 Installation when measuring liquids

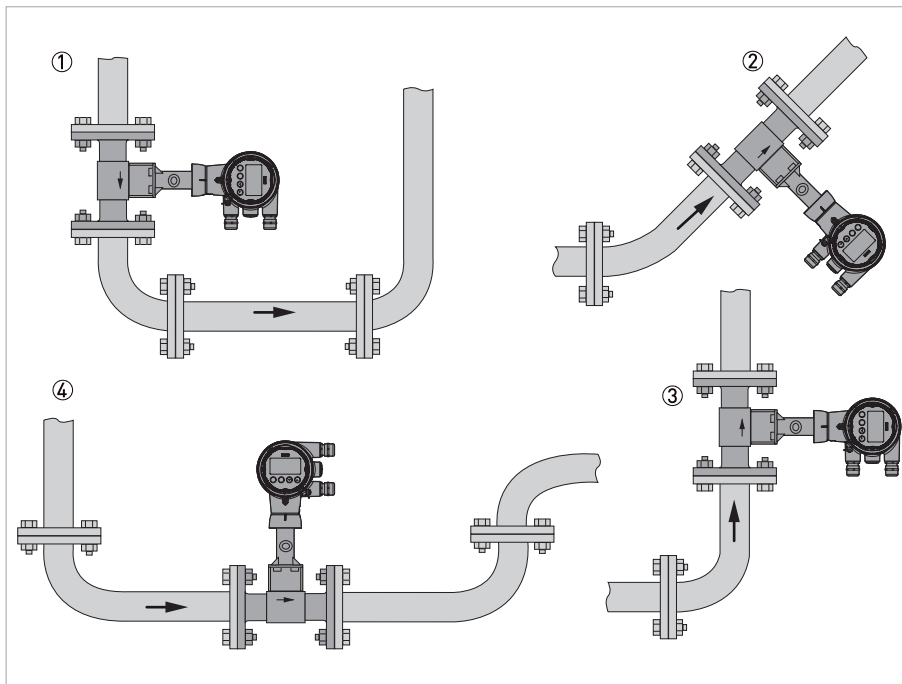

Figure 3-2: Recommended installation

- ① If the device is installed in a downpipe, a standpipe must be installed immediately after it
- ② Installing the device in an inclined standpipe
- ③ Installing the device in a vertical standpipe
- ④ Installing the device in the lower pipe bend

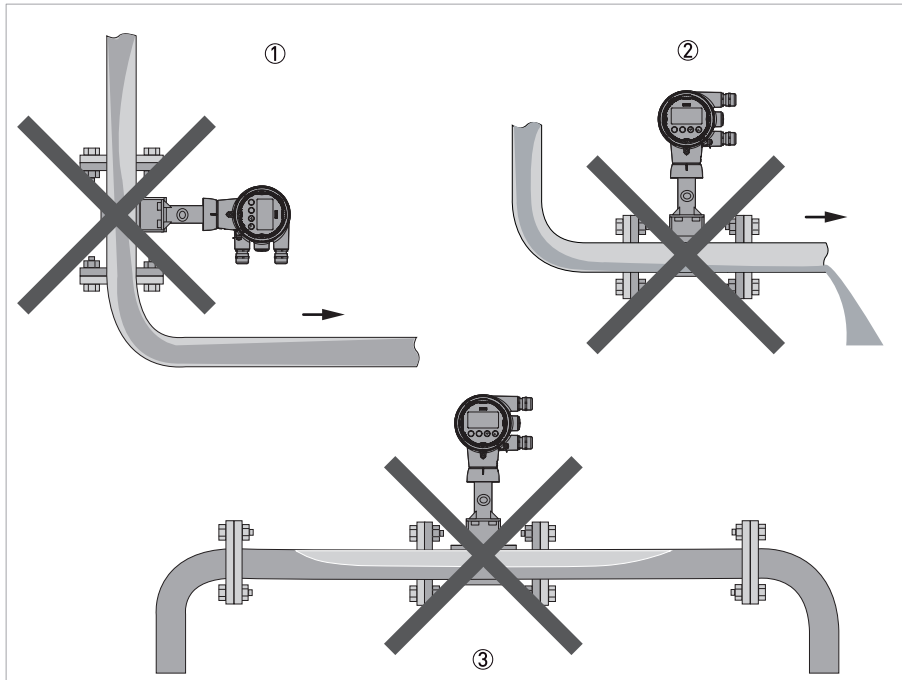

Figure 3-3: Not recommended installation

- ① Installing the device in a downstream pipe
- ② Installing the device in front of an outlet
- ③ Installing the device in an upper pipe bend due to risk of gas bubbles forming



CAUTION!

- *Installing the device in a downstream pipe ① or upstream pipe of an outlet ②, there is a risk of partially filled pipes leading to inaccurate measurements.*
- *Installing the device in an upper pipe bend ③, there is a risk of gas bubbles forming. Gas bubbles can lead to pressure surges and inaccurate measurement.*

3.4.2 Installation when measuring steam and gases

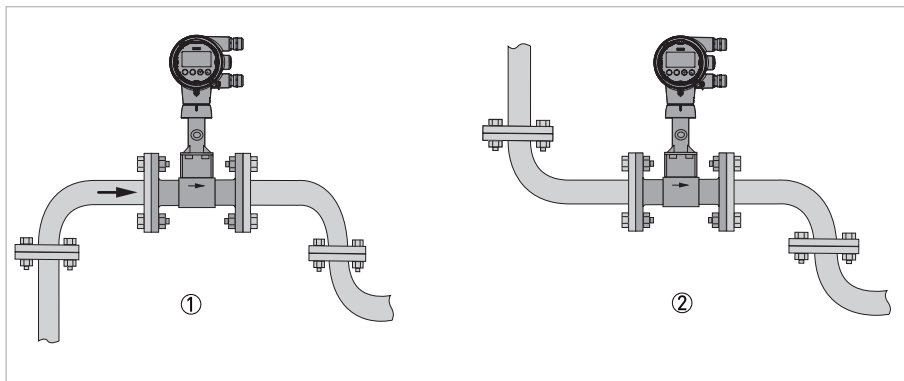

Figure 3-4: Recommended installation

- ① Installing the device in an upper pipe bend
- ② If the device is installed in a downpipe, a downpipe must be installed immediately after it

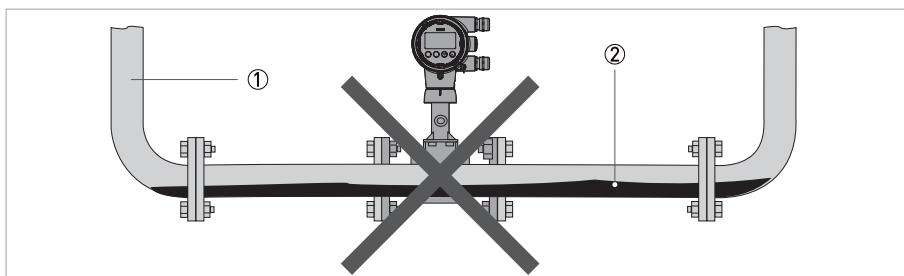

Figure 3-5: Not recommended installation

- ① Lower pipe bends
- ② Condensate

**CAUTION!**

Installing the device in a lower pipe bend: there is a risk of condensate forming. Condensate can lead to cavitation and inaccurate measurement. Under certain circumstances the device can be destroyed and the measured medium can leak.

3.4.3 Pipelines with control valve



INFORMATION!

To ensure smooth and correct measurement, the manufacturer recommends not installing the measuring device downstream from a control valve. This would run the risk of vortex formation, which would distort the measuring result.

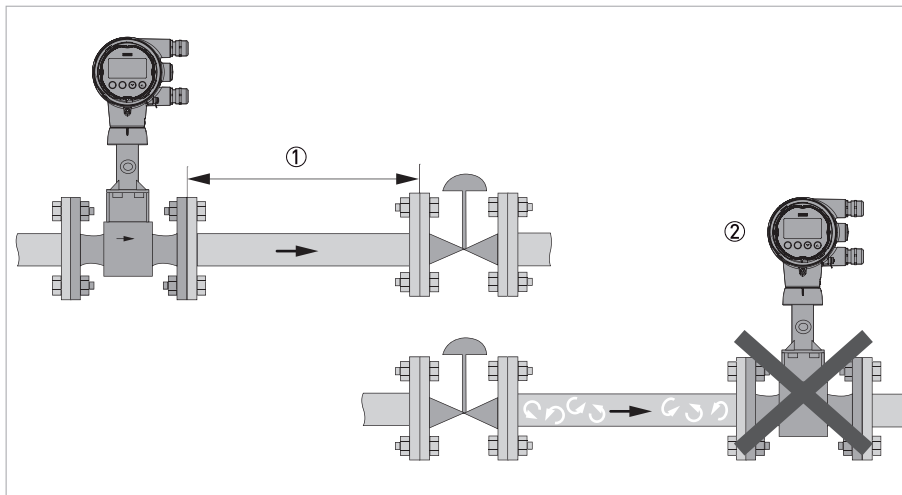

Figure 3-6: Pipelines with control valve

- ① Recommended: installing the device before the control valve at a distance of ≥ 5 DN
- ② Not recommended: installing the device directly downstream of control valves, due to vortex formation

3.4.4 Preferred mounting position

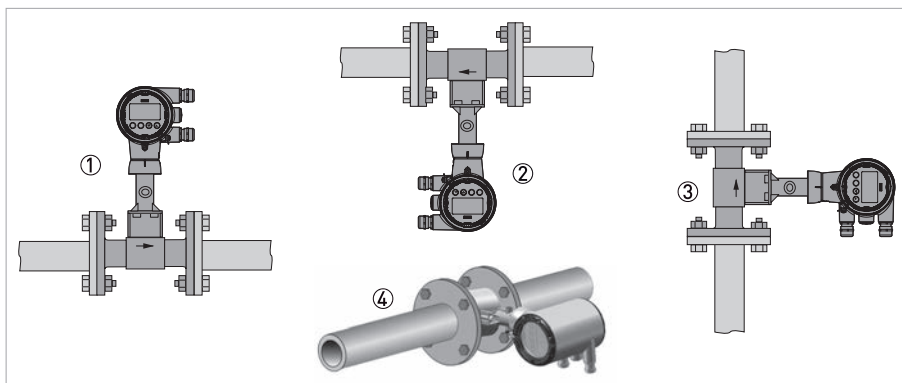

Figure 3-7: Preferred mounting position

- ① Above a horizontal pipe
- ② Underneath a horizontal pipe (not permitted with lines at risk of condensate forming)
- ③ On a vertical pipe
- ④ Horizontal pipeline with signal converter orientation of 90° to the side



INFORMATION!

Depending on the installation position, you may have to rotate the display and/or the connection housing.

3.5 Minimum inlet sections

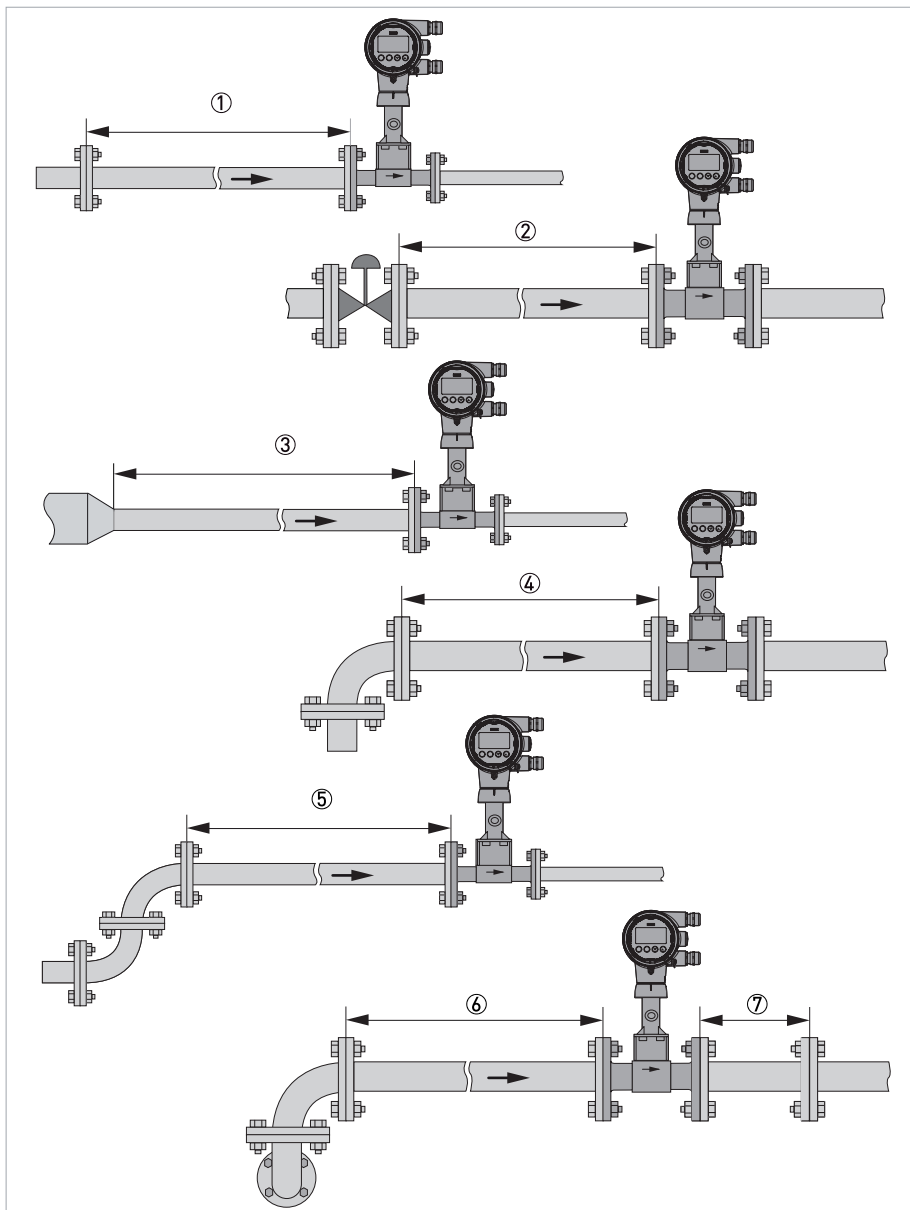

Figure 3-8: Minimum inlet sections

- ① General inlet section without disturbing flow ≥ 15 DN
- ② After a control valve ≥ 50 DN
- ③ After a pipe diameter reduction ≥ 20 DN
- ④ After a single bend $90^\circ \geq 20$ DN
- ⑤ After a double bend $2 \times 90^\circ \geq 30$ DN
- ⑥ After a double three-dimensional bend $2 \times 90^\circ \geq 40$ DN
- ⑦ Outlet section > 5 DN

**INFORMATION!**

The nominal diameter of the flange is significant for the determination of the minimum inlet and outlet sections for the nominal diameter reduced versions of vortex flowmeter versions F1R and F2R.

3.6 Minimum outlet sections

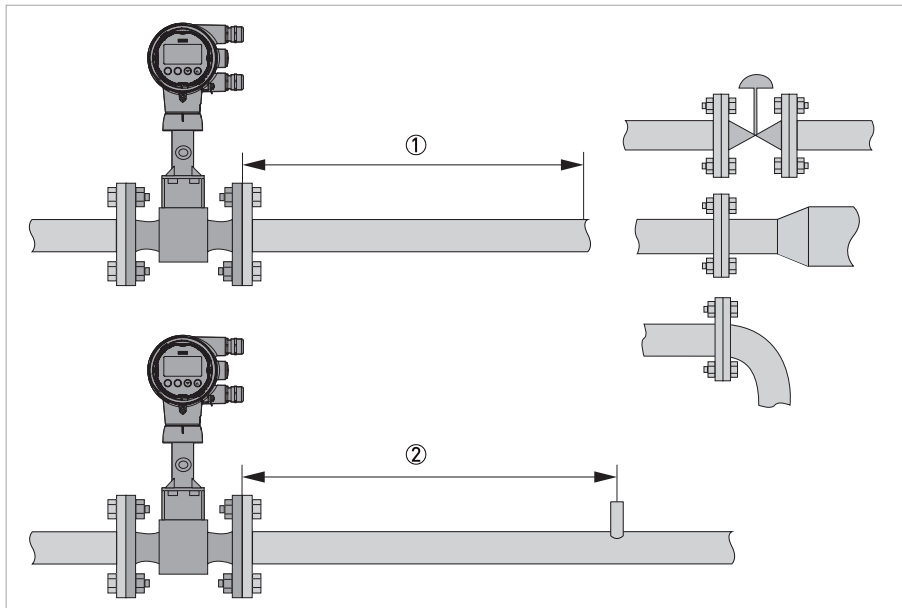

Figure 3-9: Minimum outlet sections

- ① Upstream of pipe expanders, pipe bends, control valves, etc. ≥ 5 DN
- ② Upstream of measuring points ≥ 5 DN



INFORMATION!

The interior of the pipe at the metering points must be free of burrs and other flow impediments. The distance from external temperature measuring points must be ≥ 5 DN. Use flow sensors that are as short as possible to avoid disturbances of the flow profile.

3.7 Flow straightener

If, due to the type of installation, the required inlet sections are not available, the manufacturer recommends using flow straighteners. Flow straighteners are installed between two flanges upstream of the device and shorten the required inlet section.

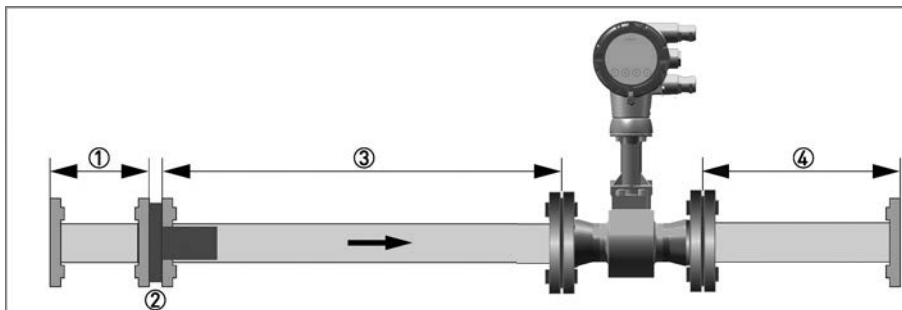

Figure 3-10: Flow straightener

- ① Straight inlet section upstream of straightener ≥ 2 DN
- ② Flow straightener
- ③ Straight pipe run between flow straightener and device ≥ 8 DN
- ④ Minimum straight outlet section ≥ 5 DN

3.8 Installation

3.8.1 General installation notes



CAUTION!

Installation, assembly, start-up and maintenance may only be performed by appropriately trained personnel. The regional occupational health and safety directives must always be observed.



The following procedures have to be carried out before installing the device:

- Ensure that the gaskets have the same diameter as the pipelines.
- Note the correct flow direction for the device. This is indicated by an arrow on the neck of the flow sensor.
- On measuring points with varying thermal loads, the devices have to be mounted with stress bolts (DIN 2510).
- Stress bolts or bolts and nuts are not included in the scope of delivery.
- Ensure that the measuring flange is concentrically fitted.
- Note the exact installation length of the measuring device when preparing the measuring point.

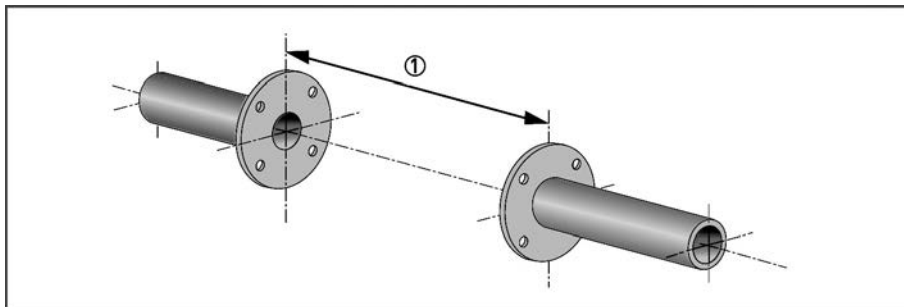

Figure 3-11: Preparing the metering point

- ① Installation length of measuring device + thickness of gaskets



CAUTION!

The inner diameter of the pipelines, the flow sensor and the gaskets must match. The gaskets may not protrude into the flow.

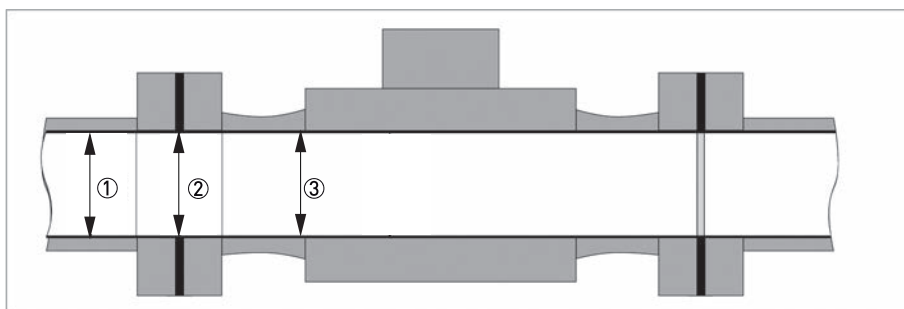

Figure 3-12: Inner diameter

- ① Inner diameter of connection pipe
 ② Inner diameter of flange and gasket
 ③ Inner diameter of flow sensor

3.8.2 Installing devices in sandwich design

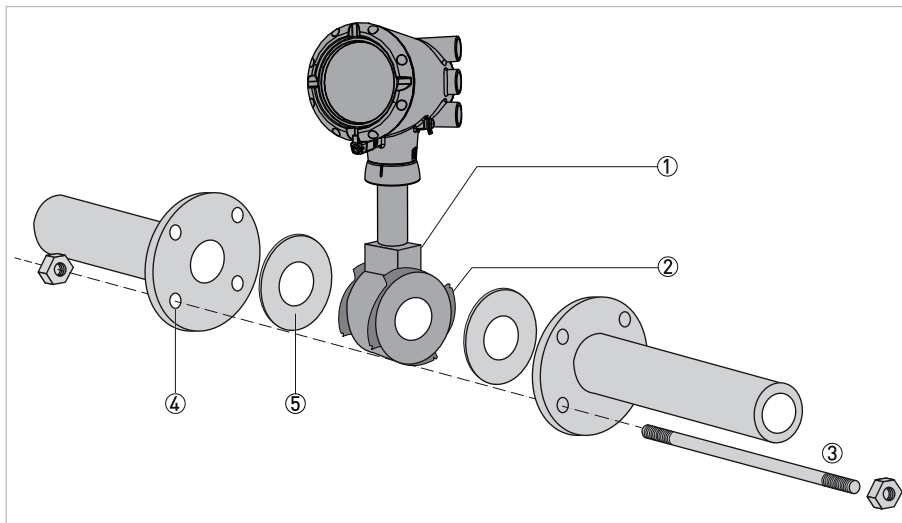

Figure 3-13: Installation using centering ring

- ① Flow sensor
- ② Centering ring
- ③ Bolts with fixing nuts
- ④ Drill hole
- ⑤ Sealing



- Push the first bolt ③ through the hole ④ of both flanges.
- Screw on the nuts and washers to both ends of the bolt ③ but do not tighten them.
- Install the second bolt through the holes ④ .
- Place the flow sensor ① between the two flanges.
- Insert the gaskets ⑤ between flow sensor ① and flanges and align them.
- Check that the flange is concentric.
- Install the remaining bolts, washers and nuts. Do not yet tighten the nuts.
- Turn the centering ring ② in a counter-clockwise direction and align the device.
- Check that the gaskets ⑤ are concentric; they must not protrude into the pipe cross-section.
- Now tighten all nuts bit by bit alternately across the diagonal.

3.8.3 Installing devices in flange design

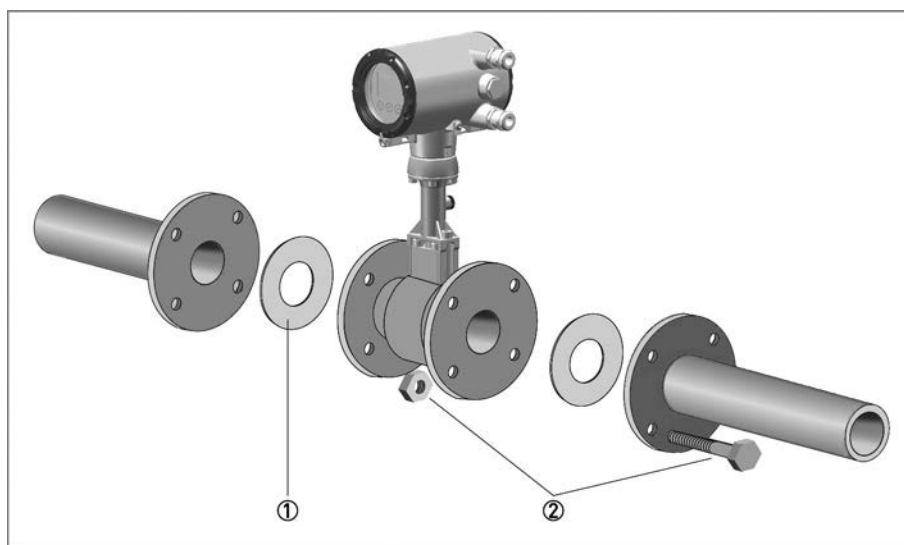

Figure 3-14: Installing devices in flange design

- ① Sealing
- ② Bolts with fastening nuts



- Use bolts and fastening nuts ② to attach the measuring device to one side of the flange.
- While doing so, insert the gaskets ① between flow sensor and flange and align them.
- Check that the gasket is concentric and that it is not protruding into the pipe cross-section.
- Install the gasket, bolts and fastening nuts on the other side of the flange.
- Align the measuring device and the gaskets so they are concentric.
- Now tighten all nuts bit by bit alternately across the diagonal.

3.8.4 Mounting the field housing, remote version



INFORMATION!

Assembly materials and tools are not part of the delivery. Use the assembly materials and tools in compliance with the applicable occupational health and safety directives.

Pipe mounting

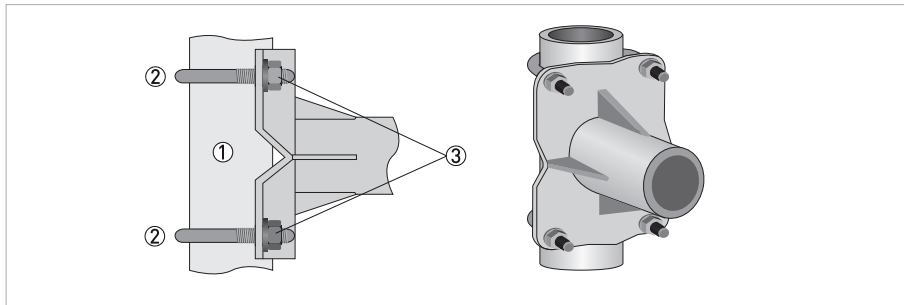

Figure 3-15: Pipe mounting of the field housing



- ① Fix the mounting bracket of the signal converter to the pipe.
- ② Fasten the mounting bracket of the signal converter using standard U-bolts and washers.
- ③ Tighten the nuts.

Wall mounting

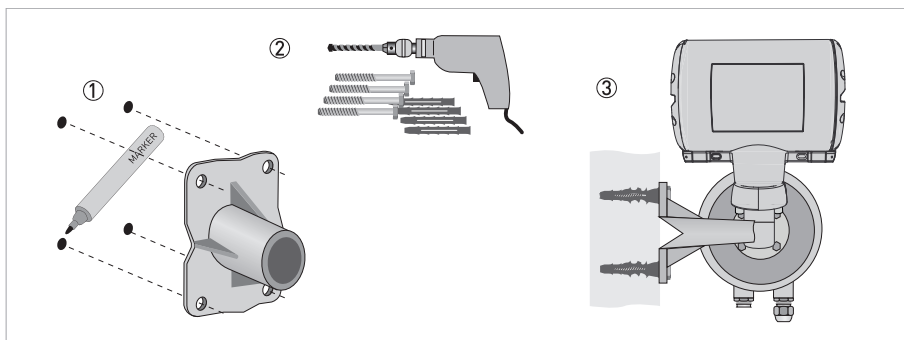

Figure 3-16: Wall mounting of the field housing



- ① Prepare the holes with the aid of the mounting plate.
- ② Use the mounting material and tools in compliance with the applicable occupational health and safety directives.
- ③ Fasten the housing securely to the wall.



INFORMATION!

Signal converters with a wall mounting rack have to be mounted with screws (Ø8 mm / 0.3") or with U-brackets (Ø8 mm / 0.3") in case of pole installation. In case of mounting directly to the wall, a mounting system with a minimum load force of 0.36 kN (for example FISCHER type SX10) suitable for the background has to be applied.

3.9 Heat insulation

**CAUTION!**

For applications with medium temperatures above $+160^{\circ}\text{C}$ / $+320^{\circ}\text{F}$ an insulation of the pipeline in accordance to the insulation guideline is suggested. Avoid higher electronic temperatures than $+80^{\circ}\text{C}$ / $+176^{\circ}\text{F}$.

The area above the signal converter support must not be heat-insulated.

The heat insulation ② may only extend to the maximum height ① shown below.

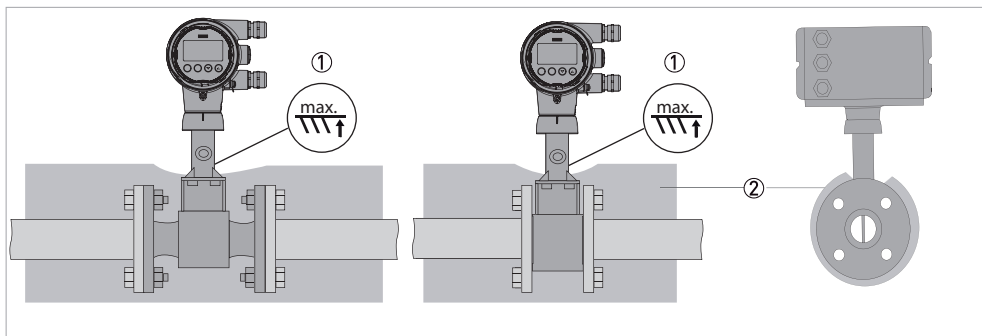

Figure 3-17: Mounting of the heat insulation

- ① Max. height of the insulation up to the marking on the neck of the flow sensor
- ② Insulation

3.10 Turning the connection housing

**DANGER!**

All work on the device electronics may only be carried out by appropriately trained personnel.
The regional occupational health and safety directives must always be observed.

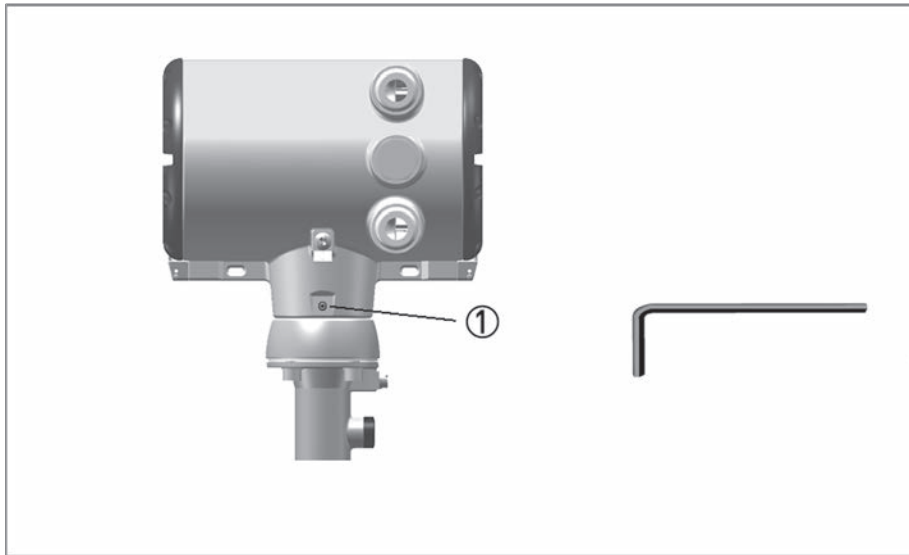

Figure 3-18: Turning the connection housing

① M4 Allen screw on connection housing



- Loosen the M4 Allen screw ① on the side of the connection housing.
- Rotate the connection housing to the desired position (0...<360°).
- Tighten the M4 Allen screw ① again.

3.11 Turning the display



DANGER!

All work on the device electronics may only be carried out by appropriately trained personnel. The regional occupational health and safety directives must always be observed.



INFORMATION!

If the measuring device is installed in a vertical pipe, you will have to turn the display by 90°; if installed below a pipe, turn 180°.



INFORMATION!

The display can be turned in increments of 90° to four positions.

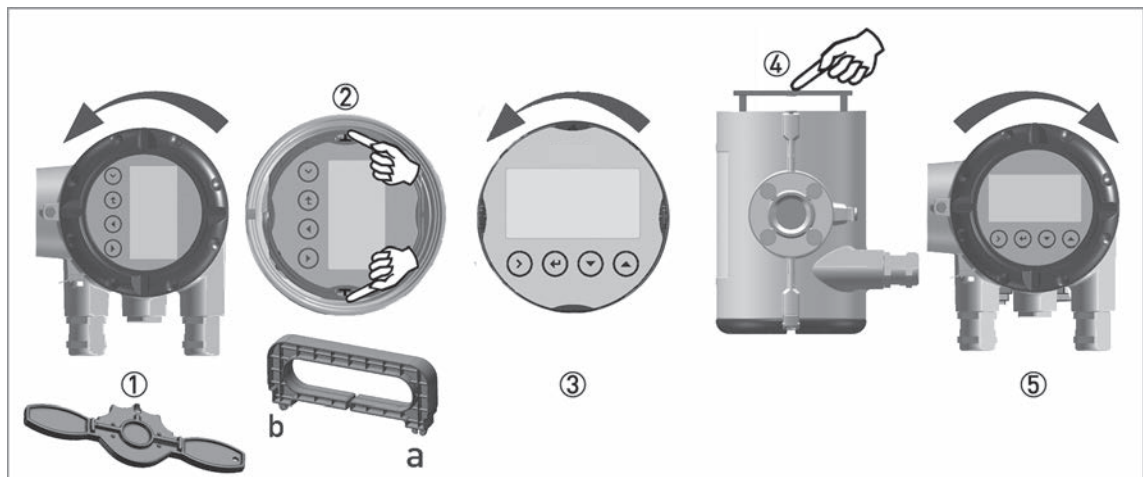

Figure 3-19: Turning the display



Turn the display as follows:

- Disconnect the power supply from the measuring device.
- Unscrew the housing cover with the key ① .
- Please use the handle to pull out the display module.
- First put the handle on side "a" and then on side "b" of the display, and then pull out the display ② carefully. Turn it into the favoured position ③ .
- Disconnect the display from the handle first on side "a" and then on side "b".
- Press the display onto the spacer pins ④ , until it clicks.
- Turn the cover with gasket ⑤ back onto the housing and tighten it by hand.



INFORMATION!

Before closing the housing cover refer to *Maintaining the O-rings* on page 77.

3.12 Weather protection cover (optional)

For installations with intense exposure to solar radiation a weather protection cover is suggested to reduce heating of the electronics.

The cover is opened and closed by operating the quarter-turn swing handle with a key supplied or a 6 mm / 0.2" inside square key. To prevent unintentional opening of the cover, make sure that the closing mechanism engages when closing the cover.

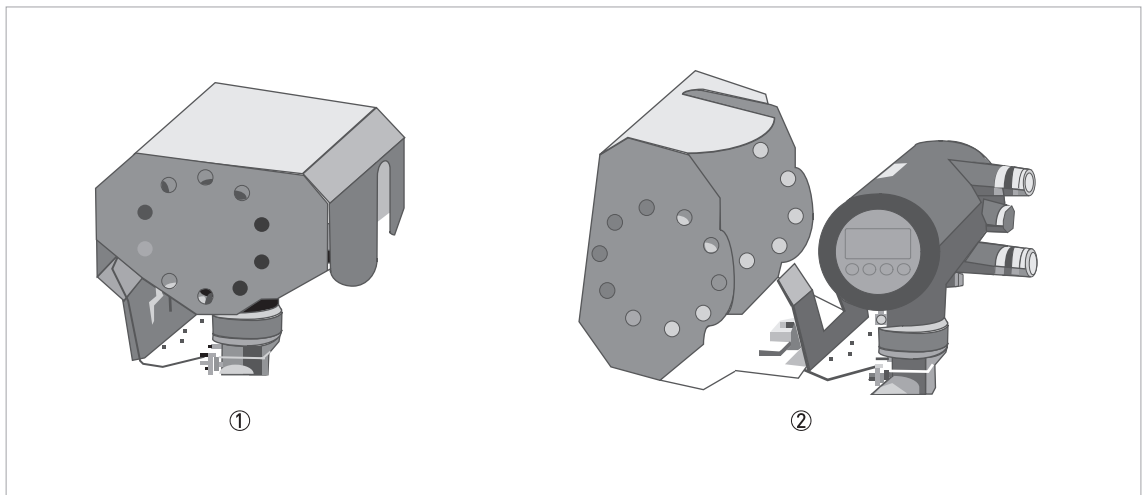

Figure 3-20: Weather protection cover

- ① Closed cover to protect the signal converter housing against intense solar radiation or vandalism
- ② Open cover for direct display reading or reconfiguration



CAUTION!

Ensure that there is an electrostatically conductive connection between the signal converter respectively the flow sensor and the protection cover when removing or installing it. When removing and re-installing the protection cover use thread locking adhesive that secures screws to prevent loosening due to shock and vibration.

4.1 Safety instructions

**DANGER!**

All work on the electrical connections may only be carried out with the power disconnected.
Take note of the voltage data on the nameplate (for details refer to Nameplate on page 18).

**DANGER!**

Observe the national regulations for electrical installations!

**DANGER!**

For devices used in hazardous areas, additional safety notes apply; please refer to the Ex documentation.

**WARNING!**

Observe without fail the local occupational health and safety regulations.
Any work done on the electrical components of the measuring device may only be carried out by properly trained specialists.

**INFORMATION!**

Look at the device nameplate to ensure that the device is delivered according to your order.
Check for the correct supply voltage printed on the nameplate.

4.2 Connecting the signal converter



DANGER!

All work on the electrical connections may only be carried out with the power disconnected.
Take note of the voltage data on the nameplate!

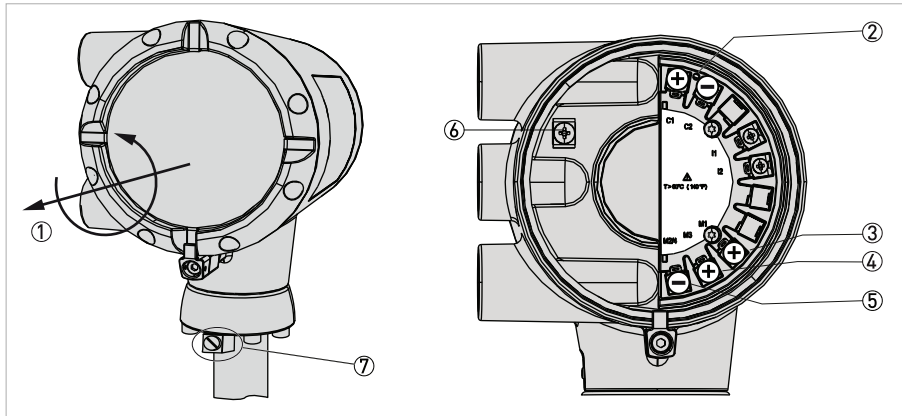

Figure 4-1: Connecting the signal converter

- ① Open the housing cover of the electrical terminal compartment using the key
- ② Signal converter supply and 4...20 mA loop
- ③ Terminal M1 pulse (high current)
- ④ Terminal M3 pulse (NAMUR)
- ⑤ Terminal M2/4 pulse, common minus connection
- ⑥ Ground terminal in housing
- ⑦ Ground terminal on connection piece between flow sensor and signal converter



INFORMATION!

Both grounding terminals ⑥ and ⑦ are equally effective from a technical point of view.



Steps for connecting the signal converter:

- Unscrew the housing cover ① of the electrical terminal compartment.
- Feed the connection cable through the cable entry in the housing.
- Connect the cable according to the terminal diagrams below.
- Connect the grounding to the terminal ⑥. Alternatively use the ground terminal ⑦ on the connection piece between the flow sensor and the signal converter.
- Tighten the cable glands.
- Turn the housing cover and gasket back onto the housing and tighten it by hand.



INFORMATION!

Ensure that the housing gasket is properly fitted, clean and undamaged.
Before closing the housing cover refer to Maintaining the O-rings on page 77.

4.3 Electrical connections

The signal converter is a 2-wire device with 4...20 mA as output signal. All other outputs are passive and always require an additional power supply.

4.3.1 Power supply

All versions are intended for connection to limited-energy circuits of max. 36 VDC / 4 A.



INFORMATION!

The supply voltage has to be between 12 VDC and 36 VDC (12...30 VDC for Ex). This is based on the total resistance of the measuring loop. To calculate this, the resistance of each component in the measuring loop (not including the device) must be added up.

The required supply voltage can be calculated using the formula below:

$$U_{\text{ext.}} = R_L * 22 \text{ mA} + 12 \text{ V}$$

with

$U_{\text{ext.}}$ = minimum supply voltage

R_L = total measuring loop resistance



INFORMATION!

The power supply has to be able to supply a minimum of 22 mA.

4.3.2 Current output

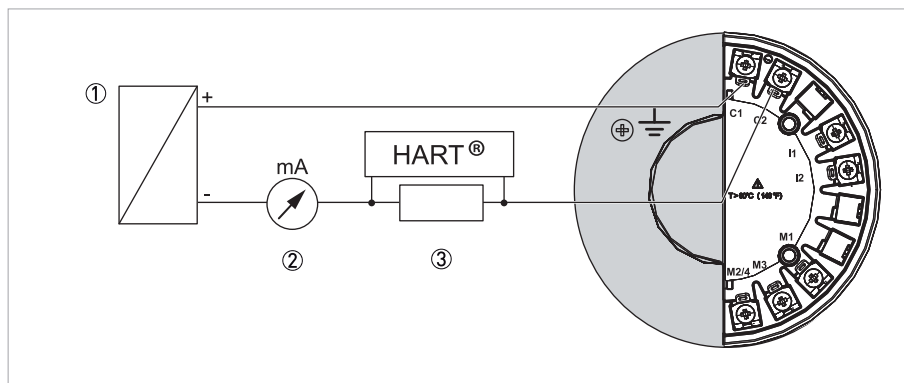

Figure 4-2: Electrical connection current output

- ① Power supply for current output
- ② Optional mA meter
- ③ Load for HART® $\geq 250 \Omega$

Connect current loop 4..20 mA to terminals C1+ and C2-.

When connection cables are long, a shielded or twisted cable may be necessary. The cable shield may only be grounded at one place (e.g. on the power supply unit).

4.3.3 Pulse output

Unless otherwise ordered, the pulse output is inactive by default and must thus be activated and configured in menu C2.2 prior to first use.

The maximum frequency of the pulse output is 1000 Hz.

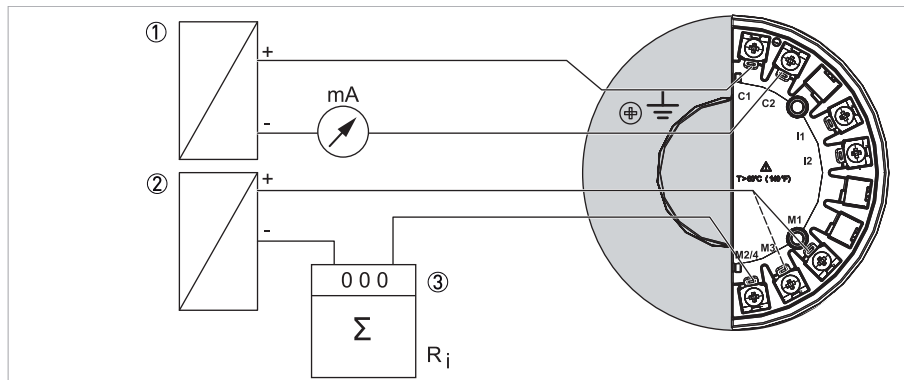

Figure 4-3: Electrical connection pulse output

- ① Signal converter power supply
- ② Pulse output power supply
- ③ Pulse counter or frequency meter

The connection is made between terminal M2/4 Common (-) and M1 for Hi Current (+) or M3 NAMUR (+). The output is a passive "open collector" output which is electrically separated from the current interface and the flow sensor. It requires its own power supply ②. The total resistance must be adapted so that the total current I_{tot} does not exceed 120 mA.

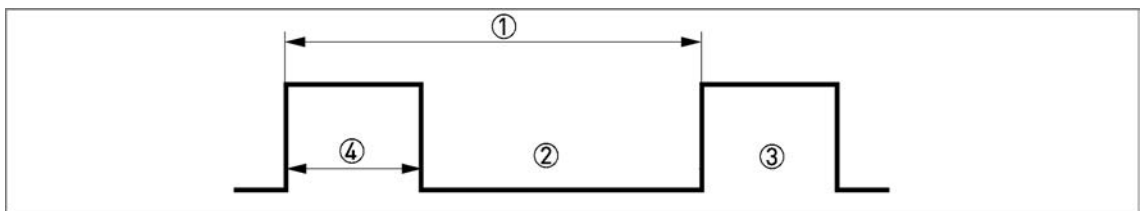

Figure 4-4: Pulse output signal definition

- ① T_{max}
- ② Closed
- ③ Open
- ④ Pulse width ≥ 0.5 ms

For selection of measurement variable and adjustable data of the pulse output refer to chapter "Menu description C - Setup", menu "C2.2.2 Pulse Output" and appropriate submenus.



INFORMATION!

Make sure the pulse width is in line with the pulse rate.

Connection of pulse output

In accordance with the desired signal transmission, select one of the following connection types for pulse output M:

- M2/4 and M3 - NAMUR
- M2/4 and M1 - Transistor output (passive, open collector)

Terminal	M1	M3	M2/4
Connection NAMUR		+ (open collector, $R_i \sim 1 \text{ k}\Omega$)	Common
Connection transistor output	+ (open collector, $I_{\text{max}} < 100 \text{ mA}$)		Common

Table 4-1: Terminal connection

	N/C contact ①	N/O contact ②
Switching value reached	< 1 mA	> 3 mA
Switching value not reached	> 3 mA	< 1 mA

Table 4-2: Value range for NAMUR

- ① C2.2.6 Invert Signal On
 ② C2.2.6 Invert Signal Off

Value range applies only when connected to a switching amplifier with the following reference values:

- Open-circuit voltage $U_0 = 8.2 \text{ VDC}$
- Internal resistance $R_i = 1 \text{ k}\Omega$

	U_L	I_L	U_H	I_H
via load R_L	0...2 V	0...2 mA	16...30 V	20...100 mA

Table 4-3: Value range for transistor output

To ensure the value ranges, a load R_L between 250Ω and $1 \text{ k}\Omega$ is recommended for the passive transistor output with a nominal voltage of 24 VDC. If other loads are used, caution is advised as the range of values of the signal voltages then no longer corresponds to the range of values for the inputs of process control systems and controls (DIN IEC 946).



CAUTION!

The upper limit of the signal current must not be exceeded as this may damage the transistor output.

4.4 Connection of remote version

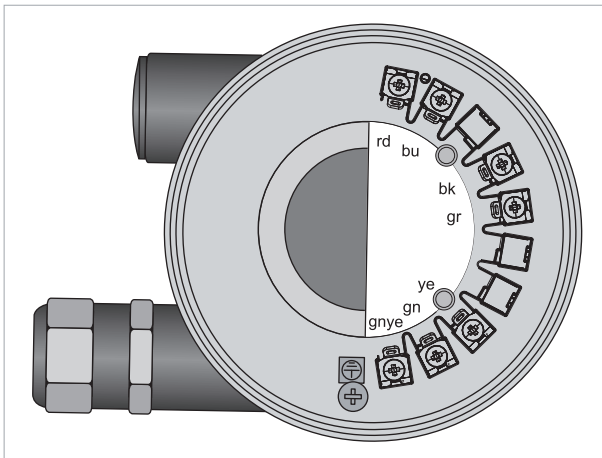

Figure 4-5: Connection terminals of remote version

The connection terminals in the connection box of the flow sensor and the wall bracket are identical in construction.

Terminals	Strand colour
rd	red
bu	blue
bk	black
gr	grey
ye	yellow
gn	green
gnye	Shielding

Table 4-4: Connection cable strand colour

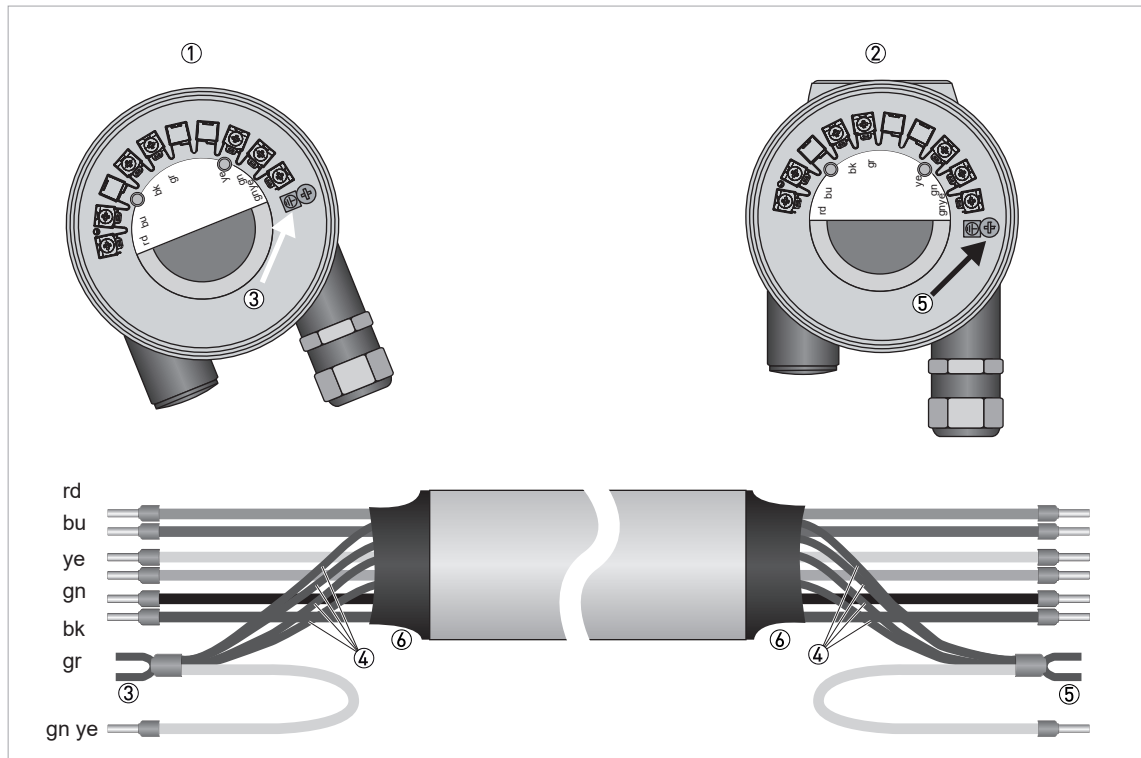

Figure 4-6: Connection of remote version

- ① Connection terminal flow sensor
- ② Connection terminal signal converter
- ③ Connection shielding flow sensor
- ④ Shielding (drain wire and overall shield)
- ⑤ Connection shielding signal converter
- ⑥ Heat shrink tubing

The maximum cable length is 50 m / 164 ft.

The cable can be shortened easily. All wires must be connected afterwards.



CAUTION!

Please ensure that the shielding ④ has been properly connected to both terminals ③ and ⑤.

4.5 Grounding connections

The grounding can be done either by connecting the PE (Protective Earth) terminal in the housing or the PE terminal on the connection piece between flow sensor and signal converter. Both of these electrical connections are equally effective from a technical point of view.

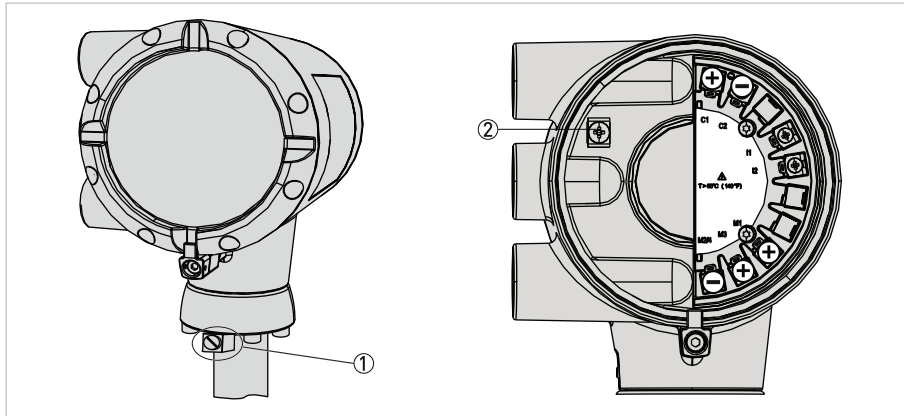

Figure 4-7: Grounding connection for compact version

- ① Electrical grounding connection on connection piece between flow sensor and signal converter.
- ② Electrical grounding terminal in the housing



CAUTION!

The measuring device has to be grounded properly to achieve accurate measurement. The grounding wire may not transfer any interference voltage. Do not use this grounding cable to ground any other electrical devices.

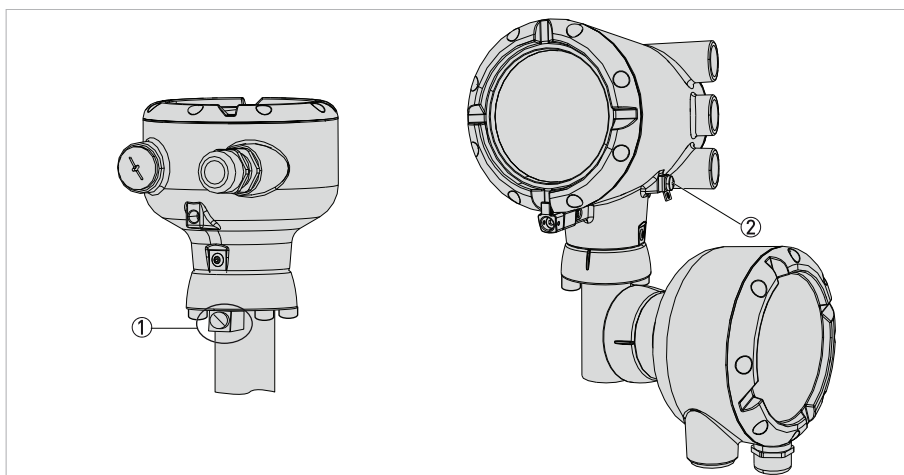

Figure 4-8: Grounding connection for remote version

- ① Electrical grounding connection on flow sensor
- ② Electrical grounding connection on signal converter housing



INFORMATION!

In the remote version, the flow sensor as well as the signal converter must be grounded.

4.6 Ingress protection

The signal converter electronics housing meets the requirements for IP66/67 in accordance with EN 60529 both for the compact and for the remote version.



CAUTION!

After all servicing and maintenance work on the measuring device, the specified ingress protection category must be ensured again.

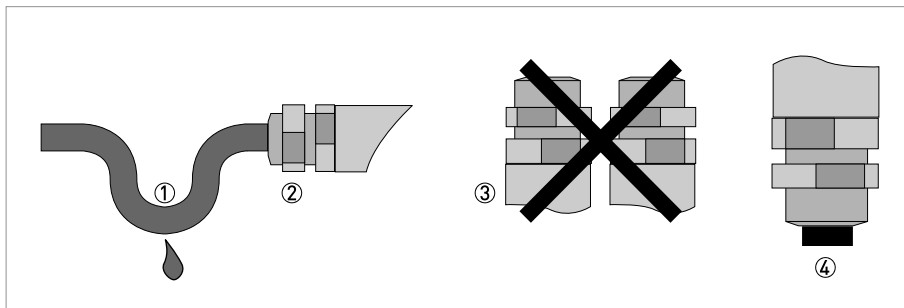

Figure 4-9: Cable gland



Therefore it is essential to observe the following points:

- Use only original gaskets. They must be clean and free of any damage. Defective gaskets must be replaced.
- The electrical cables used must be undamaged and must comply with regulations.
- The cables must be laid with a loop ① upstream of the measuring device to prevent water from getting into the housing.
- The cable glands ② must be tightened. Note that the clamping range of the cable gland corresponds to the outer diameter of the cable.
- Align the measuring device so that the cable gland is never facing up ③.
- Close any unused cable glands using blind plugs ④ suitable for the protection category.
- Do not remove the required cable bushing from the cable gland.

5.1 Start-up screen

**INFORMATION!**

After connection to power supply the device carries out a self-test. After 10 seconds the following start-up screen appears:



Figure 5-1: Start-up screen

After finishing of the self-test the device switches to the measuring mode. Here, all of the parameters preset for the customer are analysed and checked for plausibility, and the currently measured value is displayed.

5.2 Operation

**INFORMATION!**

*The measuring device is largely maintenance-free.
Observe the application limits in respect of temperature and medium.*

6.1 Display and operating elements

In case of an open front cover, the device is operated by using mechanical keys; in the case of a closed cover, a bar magnet ① is used.

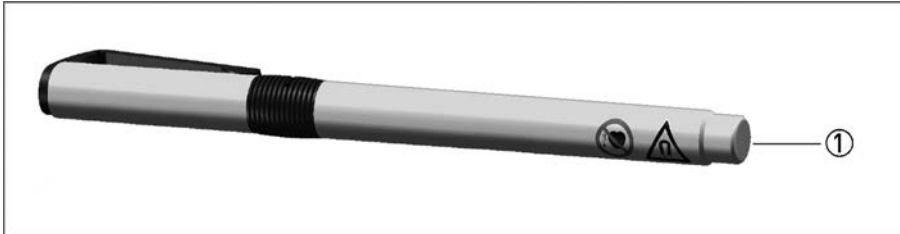

Figure 6-1: Pen with bar magnet



CAUTION!

The switching point of the magnetic sensors is directly under the glass panel above the appropriate symbol. Touch the symbol only vertically and from the front. Touching it from the side may cause a malfunction.

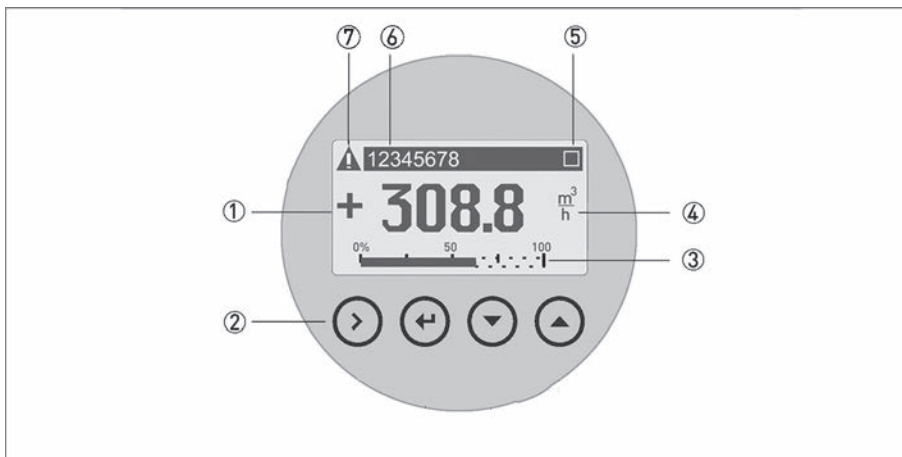

Figure 6-2: Display and operating elements

- ① Display
- ② Mechanical keys and bar magnet
- ③ Bargraph indication
- ④ 1st measured variable in large representation
- ⑤ Indicates when a key has been pressed
- ⑥ Tag number (only shown if entered previously by the operator)
- ⑦ Indicates a possible status message in the status list

The mechanical keys and keys for the bar magnet have the same functionality. In this documentation the keys are represented as symbols to describe the operating functions:





Mechanical and bar magnet	Symbol
	→
	←
	↓
	↑

Table 6-1: Description of keys

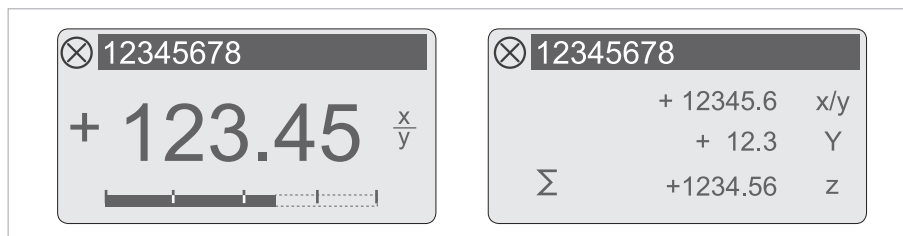

Figure 6-3: Displays in measuring mode (examples for 2 or 3 measured values)
x, y and z denote the units of the measured values displayed

6.1.1 Display for selection of submenu and functions in menu mode

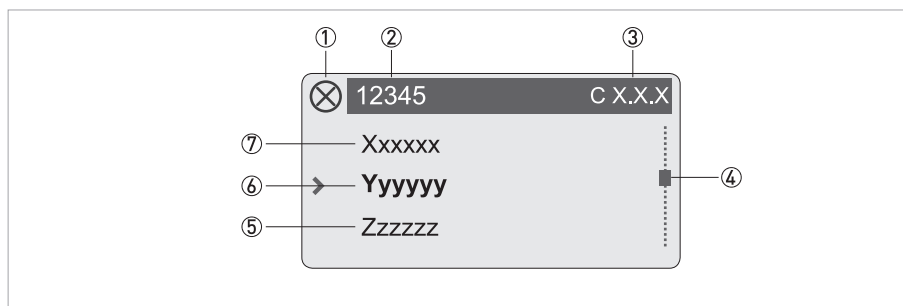

Figure 6-4: Display for selection of submenu and functions in menu mode

- ① Indicates a possible status message in the status page
- ② Menu, submenu or function name
- ③ Number relating to ⑥
- ④ Indicates position within menu, submenu or function list
- ⑤ Next menu(s), submenu or function
[__] signals in this line the end of the list
- ⑥ Current menu(s), submenu or function
- ⑦ Previous menu(s), submenu or function
[__] signals in this line the beginning of the list

6.1.2 Display when setting a parameter in parameter and data mode

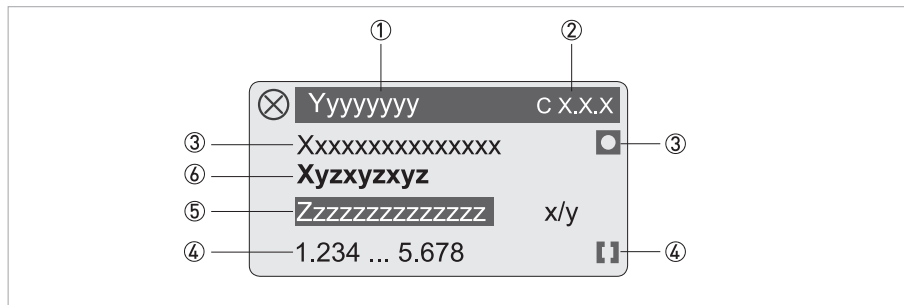

Figure 6-5: Display when setting a parameter in parameter and data mode

- ① Current menu(s), submenu or function
- ② Number related to this parameter
- ③ Factory setting of this parameter
- ④ Permissible value range for this parameter
- ⑤ Currently set value, unit or function (when selected, appears with white text, black background); this is where the parameter value is changed
- ⑥ Name of this parameter

6.1.3 Display for selection of submenu and functions with preview

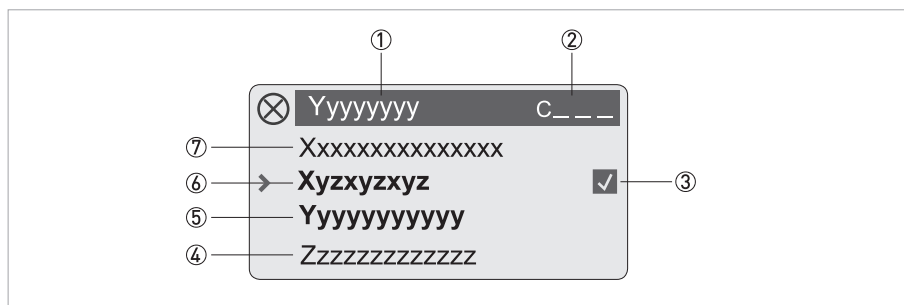

Figure 6-6: Display for selection of submenu and functions with preview

- ① Current menu(s), submenu or function
- ② Number related to ⑥
- ③ Denotes a changed parameter (simple check of changed data when browsing through lists)
- ④ Next parameter
- ⑤ Current value of parameter from ⑥
- ⑥ Current parameter (for selection press key >; then see previous chapter)
- ⑦ Previous parameter

6.2 Basic principles of operation

6.2.1 Functional description of the keys



INFORMATION!

- It is recommended to activate the push buttons perpendicular to the front. Touching them from the side can cause incorrect operation.
- The mechanical keys and keys for the bar magnet have the same functionality.

→	Switch from measuring mode to menu mode
	Switch to one menu level lower
	Open menu item and activate change mode
	In change mode: Move the input cursor one position to the right; after the last digit the input cursor jumps back to the beginning.
↑ or ↓	Change between the menu items within a menu level
	In measuring mode: Switch between 1. measurement page, 2. measurement page and status message.
	In change mode: Changing parameters and settings; running through the available characters; shifting the decimal point to the right or left.
↵	Confirm settings and changes
	Return to measuring mode

Table 6-2: Description of the operating keys

6.2.2 Switch from measuring mode to menu mode

Measuring mode	Operation	Menu mode
156.3 kg/h	→	> Quick Setup

Table 6-3: Switch from measuring mode to menu mode

Use the ↵ button to exit menu mode and return to measuring mode.

6.2.3 Change the settings in the menu

Press the → button to enter the menu.

Use the ↵ button to exit menu mode and return to measuring mode.



- Use the ↵ and ↑ or ↓ keys to navigate in the menu.
The current values or settings are displayed.
Save the new value or setting using the ↵ key.
- Some menu items contain several setting options. They are displayed in sequence by pressing the ↵ key.
- Press the ↵ button to save the settings, or to reject them.
- Before returning to measuring mode, you are prompted "Save Configuration?" which you need to accept with "Yes".
Switch between "Yes", "Back" and "No" by pressing the ↑ or ↓ keys.

Save Configuration? Yes	↵	Changes are accepted. An update is carried out and the display returns to measuring mode.
Save Configuration? No	↵	Changes are discarded. The display returns to measuring mode.
Save Configuration? Back	↵	Returns to menu mode

Table 6-4: Settings for configuration

Procedure	Display		Procedure	Display
	1.25 m ³ /h		8x ↑	Volume Flow L/h
2x →	A Quick Setup		4x ↵	Save Configuration? Yes
8x ↓	A9 Units		1x ↵	1250 L/h
2x →	Volume Flow m ³ /h			

Table 6-5: Example: Changing the default parameter from m³/h to l/h

6.2.4 Character selection in change mode

Depending on the menu function, the following characters are available:

Numbers

0	1	2	3	4	5	6	7	8	9
---	---	---	---	---	---	---	---	---	---

Lower case letters

a	b	c	d	e	f	g	h	i	j
k	l	m	n	o	p	q	r	s	t
u	v	w	x	y	z				

Upper case letters

A	B	C	D	E	F	G	H	I	J
K	L	M	N	O	P	Q	R	S	T
U	V	W	X	Y	Z				

Special characters

2	3	_	-	/	.				
---	---	---	---	---	---	--	--	--	--

6.2.5 Units, figures and factors

Numerical values and factors are displayed in a 8 digit format. Numerical values are either displayed in floating point format (12345678) or are expressed in exponential format (12.345e06). Exponents are used in following steps: 03 / 06 / 09 or -03 / -06 / -09 etc. The conversion factor of the totalizer and the pulse output, however, is expressed in whole numbers.

Flow type	Basic units
Volume flow	m ³ /s
Norm. volume flow	Nm ³ /s or Sm ³ /s
Mass flow	kg/s
Volume	m ³
Norm. volume	Nm ³ or Sm ³
Mass	kg
Density	kg/m ³

Table 6-6: Basic units

User defined units can be entered in menu "A9" or "C6.5 Units" using the elements "Text" (unit designation), "Offset" and "Factor", according to the following formula:

Text (customised unit) = (Basic unit + Offset) / Factor

Example: Defining "short ton per hour" as customised mass flow unit in menu "A9.6" or "C6.5.6":

- Upon the prompt "Text" enter "tn.sh./h"
- Upon the prompt "Offset" enter "0"
- Upon the prompt "Factor" enter "3.968323956"

Totalizer

The basic units for the totalizer are m³ for volume, Nm³ for standard volume and kg for mass. Volume flow, norm. volume flow and mass flow can be selected in menu "C4.1 Flow Totalizer". If counting is to be done in another flow unit, the unit must be changed in menu "C6.5 Units".

6.2.6 Security and permissions

Access levels

The vortex flowmeter features a multi-level security concept, which helps to prevent accidental or unauthorised configuration changes.

To gain a specific access level you need to log into the device by entering a four digit hexadecimal password associated with that access level (refer to menu "C6.2 Security"). You are able to change the passwords of "Operator" and "Expert" access levels if that particular level has been reached.

The "User" access level does not have a specific password – if you enter any password not assigned to a level, e.g. "0000" (which is an invalid password), you will fall back to "User" access level.

The table below lists the access levels, their default passwords and associated permissions.

Access level	Default password	Permissions
User	0000 (any unassigned password)	<ul style="list-style-type: none"> View device information Configure the display (C5), including changing the display language and the content of the measurement pages
Operator	0009	<ul style="list-style-type: none"> All rights of "User" access level Configure binary output (C2.2) Configure all HART[®] communication options (C3) with the exception of "C3.1.1 Current Loop Mode" Change "Operator" password (C6.2.2) – note that the new password must have three leading zeroes ("000") Activate a different meter type
Expert	0058	<ul style="list-style-type: none"> All configuration rights, especially process setup (C1) and current output (C2.1) Change "Expert" password (C6.2.2) – note that the new password must have two leading zeroes ("00")

Table 6-7: Access levels



INFORMATION!

When a particular access level has been enabled, please pay close attention to a "lock" symbol which might be present at the right side of a menu entry. This lock symbol indicates that your current access level allows you to read but not write this entry.



INFORMATION!

When entering the four digit password please be sure to type in all leading zeroes – i.e. enter the default "Operator" password as "0009" and not only "9" by skipping the remaining digits.



INFORMATION!

After a cold start of the device the user role will always be reset to "User".

Reset passwords

In case the user has changed particular passwords from their default settings and is not able to log in anymore, there is a "Reset Passwords" command available in the C6.2.3 submenu.

However to prevent unauthorised use this command itself is protected by a non-changeable unique password available by contacting the manufacturer.

6.3 Overview of the most important functions and units



INFORMATION!

A complete list of all functions and short descriptions is provided in the next section. All default parameters and settings are adapted for the customer.

Menu structure

- "A Quick Setup": Quick check and setup of the signal converter, including application assistants
- "B Test": Simulation functions and display of the actual measurement values for all variables
- "C Setup": Complete setup possibilities

Menu	Explanation
A1 Language or C5.1 Language	Select the menu language (for details refer to following chapter)
B1.2 Current Output	Check the current output
B1.3.1 Pulse Output	Check the pulse output
C1.8 Time Constant	Time constant, damping value
C2.1.2 0% Range	Minimum flow rate (current output) The set value represents the 4 mA value of the current output. Usually 0% of flow is set as 4 mA, but it is also possible to assign higher flow values to 4 mA.
C2.1.3 100% Range	Maximum flow rate (current output) The set value represents the 20 mA value of the current output. Usually 100% of flow is set as 20 mA, but it is also possible to assign lower flow values to 20 mA.

Table 6-8: Most important functions

6.4 Menu languages

English	German	French	Italian	Spanish
Czech	Polish	Chinese	Turkish	

Table 6-9: List of menu languages

6.5 Units

The following units can be selected and set in menu A9 and/or C6.5.
Furthermore, for each measurement customised units can be defined.

Liquids, steam, gases			
/d	/h	/min	/s
m ³	m ³	m ³	m ³
ml	ml	ml	ml
L	L	L	L
ML	ML	-	-
hl	hl	hl	hl
ft ³	ft ³	ft ³	ft ³
gal	gal	gal	gal
kgal	kgal	kgal	kgal
Mgal	Mgal	-	-
ImpGal	ImpGal	ImpGal	ImpGal
MImpGal	MImpGal	-	-
bbbl	bbbl	bbbl	bbbl
acft	acft	acft	acft
fl.oz[Imp]	fl.oz[Imp]	fl.oz[Imp]	fl.oz[Imp]
fl.oz[US]	fl.oz[US]	fl.oz[US]	fl.oz[US]
Customised volume flow			

Table 6-10: Units for volume flow

Liquids, steam, gases			
/d	/h	/min	/s
Nm ³	Nm ³	Nm ³	Nm ³
NL	NL	NL	NL
Sm ³	Sm ³	Sm ³	Sm ³
SL	SL	SL	SL
Sft ³	Sft ³	Sft ³	Sft ³
Customised norm./standard volume flow			

Table 6-11: Units for norm./standard* volume flow

* The units Nx/x and Sx/x shall be considered as equivalent. They serve as an indication for a normalised or standardised measuring variable and do not identify the underlying reference system.

/d	/h	/min	/s
kg	kg	kg	kg
-	g	g	g
t	t	t	-
lb	lb	lb	lb
Customised mass flow			

Table 6-12: Units for mass flow

Volume	Norm./standard* volume	Mass
m ³	Nm ³	g
L	SL	kg
hl	SM ³	oz
in ³	Sft ³	lb
ft ³	NL	T
gal		
ImpGal		
bbl		
Customised volume		

Table 6-13: Totalizer units

* The units Nx and Sx shall be considered as equivalent. They serve as an indication for a normalised or standardised measuring variable and do not identify the underlying reference system.

Temperature	Pressure	Density
°C	mbar	kg/m ³
°F	bar	kg/L
K	atm	g/cm ³
°Rank	kg/m ²	g/L
Customised temperature	kg/cm ²	g/ml
	g/cm ²	lb/gal
	torr	lb/ft ³
	psi	lb/in ³
	psi (abs)	Customised density
	b/ft ²	
	MPa	
	kPa	
	Pa	
	Customised pressure	

Table 6-14: Units for additional measurements

The pressure unit psi (abs) refers to a reference point of 0 bara / 0 psia.
 All other pressure units are gauge pressure units and refer to a reference pressure of 1.01325 bara / 14.7 psia (acc. to DIN 1343).

6.6 Menu structure



INFORMATION!

- The following tables describe the functions of the standard device with HART[®] connection.
- Depending on the device version, not all functions are available.

6.6.1 Menu overview "A Quick Setup"

Meas.	Menu A	Submenus			
> ↵	↓ ↑	> ↵	↓ ↑	> ↵	↓ ↑
	A Quick Setup		A1 Language		
			A2 Contrast		
			A3 Login		
			A4 Tag		
			A5 Long Tag		
			A6 Message View		
			A7 Fluid		
			A8 Medium		
			A9 Units	A9.1 Volume Flow	A9.2 Cst. Vol. Flow
				A9.3 Norm. Vol. Flow	A9.4 Cst. N.Vol.Flow
				A9.5 Mass Flow	A9.6 Cst. Mass Flow
				A9.9 Volume	A9.10 Cst. Volume
				A9.11 Norm. Volume	A9.12 Cst. Norm. Volume
				A9.13 Mass	A9.14 Cst. Mass
				A9.21 Density	A9.22 Cst. Density
			A11 Application Assistant	A11.1 Liquids	
				A11.5 Gas	
				A11.7 Steam (Custom)	
			A12 Cluster Checks	Cluster 1...3, 5, 6, 8...10	

Table 6-15: Menu overview "A Quick Setup"

6.6.2 Menu overview "B Test"

Meas.	Menu B	Submenus					
> ⏪	↓ ↑	> ⏪	↓ ↑	> ⏪	↓ ↑	> ⏪	↓ ↑ >
	B Test		B1 Simulation		B1.1 Set Value		B1.1.1 Volume Flow
							B1.1.2 Norm. Volume Flow
							B1.1.3 Mass Flow
							B1.1.7 Volume ①
							B1.1.8 Norm. Volume ①
							B1.1.9 Mass ①
							B1.1.16 Vortex Frequency
							B1.1.17 Velocity
							B1.1.20 Reynolds Number
					B1.2 Current Output		
					B1.3 Binary Output		B1.3.1 Pulse Output
			B2 Actual Values		B2.1 Operating Time		
					B2.2 Volume Flow		
					B2.3 Norm. Volume Flow		
					B2.4 Mass Flow		
					B2.8 Volume ①		
					B2.9 Norm. Volume ①		
					B2.10 Mass ①		
					B2.17 Vortex Frequency		
					B2.18 Velocity		
					B2.21 Reynolds Number		

Table 6-16: Menu overview "B Test"

① Depending on the settings of the totalizer "C4.1.1 Measurement"

6.6.3 Menu overview "C Setup"

Meas.	Menu C	Submenus					
> ⏪	↓ ↑	> ⏪	↓ ↑	> ⏪	↓ ↑	> ⏪	↓ ↑ >
	C Setup		C1 Process		C1.1 Fluid		Liquid Steam Gas
					C1.2 Medium		Water Air Custom
					C1.8 Time Constant		
					C1.9 Low Flow Cutoff		
					C1.10 Operating Values		C1.10.3 Oper. Density
					C1.11 Normal Values		C1.11.3 Norm. Density

Meas.	Menu C	Submenus			
> ⏪	↓ ↑	> ⏪	↓ ↑	> ⏪	↓ ↑ >
	C Setup	C2 Output	C2.1 Current Output	C2.1.1 Current Out. Meas.	
				C2.1.2 0% Range	
				C2.1.3 100% Range	
				C2.1.4 Lower Ext. Range	
				C2.1.5 Upper Ext. Range	
				C2.1.6 Error Function	
				C2.1.7 Low Error Current	
				C2.1.8 High Error Current	
				C2.1.9 Trimming	
			C2.2 Binary Output	C2.2.1 Function	
				C2.2.2 Pulse Output	
				C2.2.6 Invert Signal	
		C3 Communication	C3.1 HART	C3.1.1 Current Loop Mode	
				C3.1.2 Identification	
				C3.1.3 Device Information	
				C3.1.4 HART Variables	
		C4 Totalizer	C4.1 Flow Totalizer	C4.1.1 Measurement	
				C4.1.2 Preset Value	
				C4.1.3 Reset Totalizer?	
				C4.1.4 Set Start Value	
				C4.1.5 Start Totalizer?	
				C4.1.6 Stop Totalizer?	
				C4.1.7 Information	
		C5 Display	C5.1 Language		
			C5.2 Contrast		
			C5.3 1. Meas. Page	C5.3.1 Function	
				C5.3.2 Measurement 1. Line	
				C5.3.3 0% Range	
				C5.3.4 100% Range	
				C5.3.5 Format 1. Line	
				C5.3.6 Measurement 2. Line	
				C5.3.7 Format 2. Line	
				C5.3.8 Measurement 3. Line	
				C5.3.9 Format 3. Line	

Meas.	Menu C		Submenus				
> ⏪	↓ ↑	> ⏪	↓ ↑	> ⏪	↓ ↑	> ⏪	↓ ↑ >
	C Setup		C6 Device		C6.1 Information		C6.1.1 Tag
							C6.1.2 Long Tag
							C6.1.4 Serial Number
							C6.1.5 Manufacturer ID
							C6.1.6 Device Name
							C6.1.7 V Number
							C6.1.8 Electronic Revision
							C6.1.9 Device Revision
							C6.1.10 Software Revision
							C6.1.11 Hardware Revision
							C6.1.12 Electronic Serial No.
							C6.1.13 CG Number
							C6.1.14 Production Date
							C6.1.15 Calibration Date
					C6.2 Security		C6.2.1 Login
							C6.2.2 Change Password
							C6.2.3 Reset Passwords
					C6.4 Errors		C6.4.1 Message View
							C6.4.4 Error Mapping
					C6.5 Units		C6.5.1 Volume Flow ①
							C6.5.3 Norm. Vol. Flow
							C6.5.5 Mass Flow
							C6.5.9 Volume
							C6.5.11 Norm. Volume
							C6.5.13 Mass
							C6.5.21 Density
					C6.6 Factory Default		C6.6.1 Reset to Fact. Def.?

Table 6-17: Menu overview "C Setup"

① In all even numbered menus C6.5.2 to .22 Cst. Units (Custom Units) there is a submenu with the prompt for "Text", "Offset" and "Factor".

6.6.4 Menu description "A Quick Setup"

Function	Setting / Description
A1 Language	Available display languages: German, English, French, Italian, Spanish, Chinese, Czech, Polish, Turkish
A2 Contrast	Adjust contrast of local display (-10...+10; Standard = 0)
A3 Login	Enter password: 0000 (to change password refer to menu C6.2.2)
A4 Tag	Entry and display of measuring point identifier (8 digits).
A5 Long Tag	Entry and display of long measuring point identifier (1...32 digits). Entry will be displayed in the header bar on the LC display (depending on letter size, min. 11 digits can be displayed).
A6 Message View	NAMUR messages (F, S, M, C, I) For further information refer to <i>Status messages and diagnostic information</i> on page 70.
A7 Fluid	Select: Liquid / Steam / Gas Depending on selected fluid, appropriate medium can be selected in A8.
A8 Medium	The following selection is available for fluid = "Steam": Custom
	The following selection is available for fluid = "Liquid": Water / Custom
	The following selection is available for fluid = "Gas": Air / Custom
A9 Units	For further information refer to menu C6.5.
A11 Application Assistant	For details refer to next tables.
A12 Cluster Checks	For further information refer to <i>A12 plausibility checks</i> on page 75.

Table 6-18: Menu description "A Quick Setup"

A11 Application Assistant

The factory settings of the vortex flowmeter have been made in accordance with the order specifications. Nonetheless it can be necessary to make additional settings for the use of some functionalities. For an easy operation the device is equipped with an application assistant for each type of application. The application assistant guides the operator through the configuration of the flowmeter.

The application assistant starts with the definition of all basic units. Afterwards, the functionality-specific parameters have to be set. Settings such as configurations of the outputs or the totaliser functions, can require submenus. These can be entered by pressing the arrow " → " key. In case they are not needed, the menu items can be skipped by pressing the enter " ↵ " key.

To perform the settings for the application assistant, the operator must be logged on the access level "Expert". For further information refer to *Security and permissions* on page 52.

To abort an application assistant sequence, press " → " and " ↑ " at the same time. Be sure to select "Save Config.? No" when returning to measuring mode.

Please select a suitable application assistant from the following options:	
A11.1 Liquids	Configuration for liquid applications, incl. the correspondent output and totalizer.
A11.5 Gas	Configuration of gas applications, incl. the correspondent output and totalizer.
A11.7 Steam (Custom)	Configuration for steam applications, incl. the correspondent output and totalizer.

Table 6-19: A11 Application Assistant - general options

A11.1 Application Assistant - Liquids

Function	Setting / Description
.1	
.2 Units	
.2.1 Volume Flow	Select unit (default: according to order specification or m ³ /h).
.2.2 Mass Flow	Select unit (default: according to order specification or kg/h).
.2.3 Volume	Select unit (default: according to order specification or m ³).
.2.4 Mass	Select unit (default: according to order specification or kg).
.2.7 Density	Select unit (default: according to order specification or kg/m ³).
.3 Process	Process configuration.
.3.1 Fluid	Select "Liquid".
.3.2 Medium	Select "Water" or "Custom".
.3.3 Time Constant	0...100 s
.3.4 Low Flow Cutoff	Enter low flow cutoff point in current volume flow unit.
.4 Operating Values	Current process conditions in case they are not measured nor calculated.
.4.3 Oper. Density	Input in selected unit.
.5 Current Output	Current output configuration.
.5.1 Current Out. Meas.	Select measurement variable for current output.
.5.2 0% Range	The set value represents 4 mA at the current output. Usually 0% flow = 4 mA, but it is also possible to define a higher flow value for 4 mA.
.5.3 100% Range	The set value represents 20 mA at the current output. Usually 100% flow = 20 mA, but it is also possible to define a lower flow value for 20 mA.
.5.4 Error Function	Low / Off / High / Hold
.5.5 Low Error Current	3.5...3.6 mA, available if "Error Function = Low"
.5.6 High Error Current	21...21.5 mA, available if "Error Function = High"
.6 Binary Output	Optionally configure the binary output.
.6.1 Function	Select the binary output function: Pulse / Off
.6.2 Invert Signal	On, Off
.7 Pulse Output	This menu is available if "Binary Output Function = Pulse".
.11 Flow Totalizer	Optionally configure the flow totalizer.
.13 1. Meas. Page	One Value / Two Values / Three Values / One Value & Bargraph / Two values & Bargraph

Table 6-20: A11.1 Application Assistant - Liquids

A11.5 Application Assistant - Gas

Function	Setting / Description
.1	
.2 Units	Same options as in A11.1.2.
.2.1 Volume Flow	Select unit (default: according to order specification or m ³ /h).
.2.2 Norm. Vol. Flow	Select unit (default: according to order specification or Nm ³ /h).
.2.3 Mass Flow	Select unit (default: according to order specification or kg/h).
.2.4 Volume	Select unit (default: according to order specification or m ³).
.2.5 Norm. Volume	Select unit (default: according to order specification or Nm ³).

Function	Setting / Description
.2.6 Mass	Select unit (default: according to order specification or kg).
.2.9 Density	Select unit (default: according to order specification or kg/m ³).
.3 Process	
.3.1 Fluid	Select: "Gas".
.3.2 Medium	Select: "Air" or "Custom".
.3.3 Time Constant	0...100 s
.3.4 Low Flow Cutoff	Enter low flow cutoff point in current volume flow unit.
.7 Gas	
.8 Operating Values	Same options as in A11.1.4.
.9 Normal Values	Default settings according to order specification or DIN.
.9.3 Norm. Density	Confirm default setting or define in selected density unit.
.10 Current Output	Same options as in A11.1.5.
.11 Binary Output	Same options as in A11.1.6.
.12 Pulse Output	Same options as in A11.1.7.
.16 Flow Totalizer	Same options as in A11.1.11.
.17 1. Meas. Page	Same options as in A11.1.13.

Table 6-21: A11.5 Application Assistant - Gas

A11.7 Application Assistant - Steam (Custom)

Function	Setting / Description
.1	
.2 Units	Same options as in A11.1.2.
.3 Process	
.3.1 Fluid	Select "Steam".
.3.2 Medium	Select "Custom".
.3.3 Time Constant	0...100 s
.3.4 Low Flow Cutoff	Enter low flow cutoff point in current volume flow unit.
.6 Operating Values	Same options as in A11.1.4.
.7 Current Output	Same options as in A11.1.5.
.8 Binary Output	Same options as in A11.1.6.
.9 Pulse Output	Same options as in A11.1.7.
.13 Flow Totalizer	Same options as in A11.1.11.
.15 1. Meas. Page	Same options as in A11.1.13.

Table 6-22: A11.7 Application Assistant - Steam (Custom)

6.6.5 Menu description "B Test"

For simulation and actual values refer to *Menu overview "B Test"* on page 58.

6.6.6 Menu description "C Setup"

For further information refer to *Menu overview "C Setup"* on page 58.

Function	Setting / Description
C1 Process	
C1.1 Fluid	Select: Liquid / Steam / Gas Appropriate media can be selected in menu C1.2 dependent on selected fluid type.
C1.2 Medium	If fluid = "Liquid": Water / Custom
	If fluid = "Steam": Custom
	If fluid = "Gas": Air / Custom
C1.8 Time Constant	Enter: 0...100 s
C1.9 Low Flow Cutoff	Sets low flow values to "0". Enter value for low flow cutoff in volumetric flow unit.
C1.10 Operating Values	Operating values are pre-set according to the application data; value can be adjusted subsequently, if required.
C1.10.3 Oper. Density	Enter value in selected density unit.
C1.11 Normal Values	Standard system values are pre-set according to the application data, if applicable. Standard system can be changed by changing values in C1.11.3.
C1.11.3 Norm. Density	Enter value in selected density unit.

Table 6-23: Menu description C1

Function	Setting / Description
C2 Output	
C2.1 Current Output	2-wire current output 4..20 mA (for details refer to <i>Technical data</i> on page 86)
C2.1.1 Current Out. Meas.	Determination of measurement variable for current output. Measurement variable for current output is pre-set according to application data. Select: Volume Flow / Norm. Volume Flow / Mass Flow / Density / Vortex Frequency / Velocity
C2.1.2 0% Range	The set value represents the 4 mA value of the current output. Usually 0% of flow is set as 4 mA, but it is also possible to assign higher flow values than 4 mA.
C2.1.3 100% Range	The set value represents the 20 mA value of the current output. Usually 100% of flow is set as 20 mA, but it is also possible to assign lower flow values than 20 mA.
C2.1.4 Lower Ext. Range	Minimum limit of current value. Pre-set value is 4 mA. Enter: 3.8...4 mA Condition for value < 4 mA: Measurement value at 4 mA must not be smaller or equal to 0%.
C2.1.5 Upper Ext. Range	Maximum limit of current value. Pre-set value is 20 mA. Enter: 20...20.5 mA Condition for value > 20 mA: Measurement value at 20 mA must not be greater or equal to 100%.
C2.1.6 Error Function	This function triggers a current output signal in case of an error detection with status type F (for details refer to <i>Status messages and diagnostic information</i> on page 70). Select: - Off: No error current signal is sent. - High: Error current signal as defined in C2.1.7 is sent. - Low: Error current signal as defined in C2.1.8 is sent. - Hold: Last current value is held.

Function	Setting / Description
C2 Output	
C2.1.7 Low Error Current	Enter: 3.5...3.6 mA, available if "Error Function = Low"
C2.1.8 High Error Current	Enter: 21...21.5 mA, available if "Error Function = High"
C2.1.9 Trimming	This function enables to trim the current output. Trimming is started by entering the menu.
C2.1.9.2 4mA Trimming	Trimming of 4 mA point. Enter measured value for 4 mA point. Reset to 4 mA restores the factory calibration.
C2.1.9.5 20mA Trimming	Trimming of 20 mA point. Enter measured value for 20 mA point. Reset to 20 mA restores the factory calibration.
C2.2 Binary Output	For further information refer to <i>Pulse output</i> on page 39
C2.2.1 Function	Select: Off / Pulse Unless otherwise ordered the binary output is inactive.
C2.2.2 Pulse Output	Only available if "Pulse" is selected in C2.2.1.
C2.2.2.1 Measurement	Select: Volume Flow / Mass Flow / Norm. Volume Flow
C2.2.2.2 Value p. Pulse	Define value per pulse in unit according to measurement variable selection.
C2.2.2.3 Pulse Width	Define pulse width in ms.
C2.2.2.4 100% Pulse Rate	Define 100% pulse rate in Hz.
C2.2.6 Invert Signal	Select: On (normally open) / Off (normally closed)

Table 6-24: Menu description C2

Function	Setting / Description
C3 Communication	
C3.1 HART	
C3.1.1 Current Loop Mode	Select: On (enables primary variable to be transmitted as 4...20 mA current values) / Off (disables 4...20 mA transmission, but enables HART [®] multi-drop mode)
C3.1.2 Identification	HART [®] Identification parameters
C3.1.2.1 Polling Address	Set address for HART [®] operation. Standard setting is 000 for point-to-point operation with current output 4...20 mA. Setting of polling address \neq 000 causes a constant 4 mA output and enables multi-drop mode. Enter: 000...063
C3.1.2.2 Tag	Enter measuring point identifier (1...8 digits).
C3.1.2.3 Long Tag	Enter long measuring point identifier (1...32 digits). Entry will be displayed in the header bar on the LC display (depending on letter size, min. 11 digits can be displayed).
C3.1.2.4 Manufacturer ID	HART [®] Manufacturer ID = 00069 (0x45) [KROHNE] (read-only)
C3.1.2.5 Device Type	Device Type = 00205 (0xCD) (read-only)
C3.1.2.6 Device ID	Individual device ID (read-only)
C3.1.2.7 Universal Revision	HART [®] revision (read-only)
C3.1.2.8 Device Revision	(read-only)
C3.1.2.9 Software Revision	(read-only)
C3.1.2.10 Hardware Revision	(read-only)

Function	Setting / Description
C3 Communication	
C3.1.3 Device Information	Informative text can be added to describe the device in the HART® communication loop.
C3.1.3.1 Descriptor	Commenting text to label instrument can be added; 1...16 digits.
C3.1.3.2 Message	Here additional information can be added.
C3.1.3.3 Date	Customer-defined date can be set here.
C3.1.3.4 Cfg. Change Counter	Counter for changes in settings (read-only).
C3.1.4 HART Variables	Definition of HART® variables.
C3.1.4.1 Current Out. Meas.	Primary HART® variable; identical with current output measurement variable.
C3.1.4.4 Quaternary HART	Select (availability depending on fluid and medium configuration): Volume Flow / Norm. Volume Flow / Mass Flow / Volume / Norm. Volume / Density / Vortex Frequency / Velocity / Reynolds Number

Table 6-25: Menu description C3

Function	Setting / Description
C4 Totalizer	
C4.1 Flow Totalizer	
C4.1.1 Measurement	Select: Volume Flow / Norm. Volume Flow / Mass Flow "Norm. Vol." is only available if fluid is "Gas".
C4.1.2 Preset Value	Set value, which triggers event "Flow Totalizer Overflow" (for details refer to <i>Status messages and diagnostic information</i> on page 70).
C4.1.3 Reset Totalizer?	Select: Yes / No
C4.1.4 Set Start Value	Set start value in selected unit. Start value has to be confirmed with "Yes" or refused with "No".
C4.1.5 Start Totalizer?	Select: Yes / No
C4.1.6 Stop Totalizer?	Select: Yes / No
C4.1.7 Information	Display of current totalizer values. The menus C4.1.7.1 to C4.1.7.3 are available depending on selected measurement variable in C4.1.1.
C4.1.7.1 Volume	Display of current totalizer value for volume flow.
C4.1.7.2 Norm. Volume	Display of current totalizer value for norm. volume flow.
C4.1.7.3 Mass	Display of current totalizer value for mass flow.

Table 6-26: Menu description C4

Function	Setting / Description
C5 Display	
C5.1 Language	Available display languages: German, English, French, Italian, Spanish, Chinese, Czech, Polish, Turkish
C5.2 Contrast	Adjust contrast of local display (-10...+10).
C5.3 1. Meas. Page	Configuration of the first measurement display page.
C5.3.1 Function	Select: One Value / Two Values / Three Values / One Value & Bargraph / Two Values & Bargraph

Function	Setting / Description
C5 Display	
C5.3.2 Measurement 1. Line	Select: Volume Flow / Norm. Volume Flow / Mass Flow / Volume / Norm. Volume / Mass / Density / Vortex Frequency / Velocity / Reynolds Number
C5.3.3 0% Range	The set value represents the 0% point of the bargraph indication. Usually 0% flow = 4 mA, but it is also possible to define a higher flow value for 4 mA. This menu is only available, if an option containing a bargraph was selected in C5.3.1.
C5.3.4 100% Range	The set value represents the 100% point of the bargraph indication. Usually 100% flow = 20 mA, but it is also possible to define a lower flow value for 20 mA. This menu is only available, if an option containing a bargraph was selected in C5.3.1.
C5.3.5 Format 1. Line	Automatic or 1...8 digits
C5.3.6 Measurement 2. Line	Same as C5.3.2, visible if more than one value was selected in C5.3.1.
C5.3.7 Format 2. Line	Same as C5.3.5, visible if more than one value was selected in C5.3.1.
C5.3.8 Measurement 3. Line	Same as C5.3.2, visible if three values were selected in C5.3.1.
C5.3.9 Format 3. Line	Same as C5.3.5, visible if three values were selected in C5.3.1.

Table 6-27: Menu description C5

Function	Setting / Description
C6 Device	
C6.1 Information	
C6.1.1 Tag	Entry and display of measuring point identifier (8 digits).
C6.1.2 Long Tag	Entry and display of long measuring point identifier (1...32 digits). Entry will be displayed in the header bar on the LC display (depending on letter size, min. 11 digits can be displayed).
C6.1.4 Serial Number	Individual device ID (read-only).
C6.1.5 Manufacturer ID	HART [®] Manufacturer ID = 00069 (0x45) [KROHNE] (read-only)
C6.1.6 Device Name	Optiswirl 2100 (read-only)
C6.1.7 V Number	Internal order number (read-only).
C6.1.8 Electronic Revision	Electronic revision of this device as listed on device nameplate (for details refer to <i>Software history</i> on page 6).
C6.1.9 Device Revision	(read-only)
C6.1.10 Software Revision	(read-only)
C6.1.11 Hardware Revision	(read-only)
C6.1.12 Electronic Serial No.	Individual ID of electronics component (read-only).
C6.1.13 CG Number	Article code for signal converter hardware (read-only).
C6.1.14 Production Date	(read-only)
C6.1.15 Calibration Date	(read-only)
C6.2 Security	
C6.2.1 Login	Enter four digit password to gain a specific access level (for details refer to <i>Security and permissions</i> on page 52).
C6.2.2 Change Password	Change the password associated to the access level currently active.
C6.2.3 Reset Passwords	Reset all passwords to their default setting (for details refer to <i>Security and permissions</i> on page 52).
C6.4 Errors	

Function	Setting / Description
C6 Device	
C6.4.1 Message View	NAMUR messages (F, S, M, C, I) For further information refer to <i>Status messages and diagnostic information</i> on page 70.
C6.4.4 Error Mapping	For specific NE 107 events it is possible to redefine the status type.
C6.4.4.1 Totalizer	This function defines the NE 107 status type for the totalizer overflow. Select: Information / Maintenance Request / Out of Specification / Function Check / Failure / None

Table 6-28: Menu description C6.1 - C6.4

Function	Setting / Description
C6 Device	
C6.5 Units	
6.5.1 Volume Flow	C6.5.2 Cst. Volume Flow In all even numbered menus C6.5.2 to .22 Cst. Units (Custom Units) there is a submenu with the prompt for "Text", "Offset" and "Factor".
6.5.3 Norm. Vol. Flow	6.5.4 Cst. Norm. Vol. Flow
6.5.5 Mass Flow	6.5.6 Cst. Mass Flow
6.5.9 Volume	6.5.10 Cst. Volume
6.5.11 Norm. Volume	6.5.12 Cst. Norm. Volume
6.5.13 Mass	6.5.14 Cst. Mass
6.5.21 Density	6.5.22 Cst. Density
C6.6 Factory Default	
C6.6.1 Reset to Fact. Def.?	Query: Reset to Fact. Def.? Press " → " and confirm reset to factory default with "Yes" or refuse with "No".

Table 6-29: Menu description C6.5 - C6.6

6.7 Status messages and diagnostic information

The diagnostic messages are displayed in accordance with NAMUR standard NE 107. The error messages for the device are divided into status groups, each with one status signal. There are 16 status groups with fixed status signals and 8 groups with variable status signals. To facilitate identification of the problem source, the status groups are then divided into: Sensor, Electronics, Configuration and Process.



INFORMATION!

As a status message, always the event group name and the the status signal (F/S/M/C) are displayed.

Each status message (= status signal) has a specific symbol, determined by NAMUR, which is displayed with the message. The length of each message is limited to one line.





Symbol	Letter	Status signal	Description and consequence
	F	Failure	No measurement possible.
	S	Out of specification	Measurements are available but are no longer sufficiently accurate and should be checked.
	M	Maintenance required	Measurements are still accurate but this could soon change.
	C	Function check	A test function is active. The displayed or transferred measured value does not correspond to the actual measured value.
	I	Information	No direct influence on the measurements.

Table 6-30: Symbols for status messages



INFORMATION!

Some of the following elimination measures require a hard reset. In case a hard reset is performed please wait for approx. 10 seconds before powering the device again.

Status type	Event group	Single event	Description	Actions to eliminate the event
F	Sensor			
		Sensor Comm. Error	An internal error in the sensor module has occurred. Error in the internal bus communication or hardware failure.	For remote version: Check the sensor connection. All versions: Perform a hard reset. If the message recurs, contact the manufacturer.
		Corrupt Sensor Parameter	Sensor parameters are inconsistent	Check sensor parameters.
		Failed Sensor Input Test	The continuous self test of the sensor electronic failed.	Perform a hard reset. If the message recurs, contact the manufacturer.
		Failed Sensor MCU Test	The continuous self test of the sensor electronic failed.	Perform a hard reset. If the message recurs, contact the manufacturer.
		No Measurement Value	Q_v or Q_m have timed out or are inconsistent.	For remote version: Check the sensor connection. All versions: Perform a hard reset. If the message recurs, contact the manufacturer.
		Temporary Piezo Error	Piezo signals partly disturbed.	Check the process conditions, proper shielding/grounding and the installation situation. Perform a hard reset. If the message recurs, contact the manufacturer.
		Fatal Piezo Error	Piezo signals disturbed.	Check the process conditions, proper shielding/grounding and the installation situation. Perform a hard reset. If the message recurs, contact the manufacturer.
		Piezo Path disrupted	Sensor electronics error.	Perform a hard reset. If the message recurs, contact the manufacturer.
	Piezo Shortcut	Shortcut on piezo or sensor electronics detected.	Perform a hard reset. If the message recurs, contact the manufacturer.	

Status type	Event group	Single event	Description	Actions to eliminate the event
F	Electronics			
		Fatal DM Error	Internal error.	Perform a hard reset. If the message recurs, contact the manufacturer.
		Fatal CO Error	Internal error.	
		Fatal Converter Error	An electronics or hardware failure has occurred.	
		Internal Comm. Error	Error in the internal bus communication.	Perform a hard reset. If the message recurs, contact the manufacturer.
		Inconsistent Parameters	Error in the internal bus communication.	Check the parameters and make sure that the set of data is consistent. Additional information on the error can be called via HART [®] interface.
		Sensor Comm. Error	Error in the internal bus communication or hardware failure.	Perform a hard reset. If the message recurs, contact the manufacturer.
		Power Supply Error	Internal voltage too low to switch on sensor power supply.	Check power supply connection or replace the electronics.
		Sensor/Conv. FW Mismatch	Incompatible firmware versions in the sensor and the converter module.	Perform a hard reset. If the message recurs, contact the manufacturer.
		Max. Number of Restarts	The device could not start the measuring mode after a cold starting.	Perform a hard reset once again. If the message recurs, contact the manufacturer.
		Converter Overvoltage	An electronics or hardware failure has occurred.	Perform a hard reset. If the message recurs, contact the manufacturer.
		Intern. Comm. Error	Error in the internal bus communication.	Perform a hard reset. If the message recurs, contact the manufacturer.
F	Configuration			
		Inconsistent NVRAM	Inconsistent data in the parameter memory.	Perform a hard reset. If the message recurs, contact the manufacturer.
		CO Float Error	Error in processing of the measuring value due to inconsistent set of parameter.	Load the factory settings and perform a hard reset. If the message recurs, contact the manufacturer.
		Incons. Converter Calib.	Faulty calibration data in the converter module.	Contact the manufacturer.
		Incons. Sensor Calibration	Faulty calibration data in the sensor module.	
		NVRAMs Mismatch	Incompatible serial numbers of display and electronic module.	Use displays and electronic modules, which belong together. Contact the manufacturer, if necessary.
		Conv. NVRAM Layout Error	Incompatible data in parameter memory.	Perform a hard reset. If the message recurs, contact the manufacturer.
Disp. NVRAM Layout Error		Incompatible data after firmware update.		

Status type	Event group	Single event	Description	Actions to eliminate the event
C	Electronics			
		Firmware Update Active	A firmware update of the converter module has been started.	Wait for firmware update to finish.
C	Configuration			
		Sensor Sim. Active	A simulation of the sensor is active.	Stop the simulation of the sensor variables.
		Current Out. Sim. Active	A simulation of the current output is active.	Stop the simulation of the current output variables
		HART Sim. Active	Simulation of a measuring value via HART® interface.	Stop the simulation via the HART® interface.
		Flow Comp. Sim. Active	A simulation of measurement value processing is active.	Stop the simulation of the measurement value processing.
		Binary Output Sim. Active	A simulation of the binary output is active.	Stop the simulation of the binary output variables.
S	Sensor			
		Flow Meas. Out of Spec.	The vortex frequency or the volume flow is out of range. The real flow is higher or lower than the indicated value.	Check the process conditions.
		Low Flow Cutoff Undercut	Volume flow is lower than low flow cutoff (LFC)	Check the low flow cut-off or the process conditions.
		Weak Flow Meas. Signal	The vortex signal is too weak or disturbed.	Check the process conditions and the installation situation. Eliminate external disturbances. If the message recurs, contact the manufacturer.
		Elec. Temp. Out Of Spec.	The electronic temperature of the sensor module is out of specification.	Make sure that the device is operated within the permissible temperature range.
S	Electronics			
		Elec. Temp. Out Of Spec.	The electronic temperature of the converter is out of specification.	Make sure that the device is operated within the permissible temperature range.
S	Process			
		CO Undersaturation	The measurement value is lower than the lower range value of the current output. The current output is saturated and does not reflect the effective measuring value.	Check the process conditions and the lower current output limit.
	CO Oversaturation	The measurement value is higher than the upper range value of the current output. The current output is saturated and does not reflect the effective measuring value.	Check the process conditions and the upper current output limit.	

Status type	Event group	Single event	Description	Actions to eliminate the event
I	Config: Totalizer ①			
		Flow Totalizer Overflow	The actual value of the flow counter exceeds its preset value.	Check the setting of the flow counter or reset the counter.
M	Sensor Information			
		Faulty Sensor Oscillator	The sensor oscillator is working out of range.	Perform a hard reset. If the message recurs, contact the manufacturer.
		Faulty sensor voltage ref.	Reference voltage in sensor module out of specification.	
M	Electronics Information			
		Faulty Converter Oscillator	The converter oscillator is working out of range.	Perform a hard reset. If the message recurs, contact the manufacturer.
		Faulty conv. voltage ref.	Reference voltage in converter module out of specification.	

Table 6-31: Status messages

① Status type depends on "C6.4.4.1 Error Mapping Totalizer"

6.8 A12 plausibility checks

When configuring the device, a number of complex "cluster" checks are run internally on the proposed configuration in order to make sure it is valid. Thus when saving a configuration the device might raise an error like this: "Failed E01", which indicates an error cluster number. In this case please consult the indicated cluster number in the following table to find out which parameters are affected.

You may also want to enter in the quick setup menu "A12 Cluster Checks" and check each setting in the affected "cluster" submenu.

No.	Name	Explanation of plausibility checks
01	Sensor Configuration / Fluid	After changing fluid or operating density the device checks whether the measurement variables configured at the device's outputs are still valid (HART [®] variables, pulse output, local display and flow totalizer). Also their configured ranges are checked.
02 03	Medium	When selecting the medium the device checks whether the measurement variables configured at the device's outputs are still valid (HART [®] variables, pulse output, local display and flow totalizer).
05	Current output / primary HART variable	Checks if selected measurement variable is valid. Also checks limit settings for 0% and 100%.
06	Secondary HART variable	Checks if the secondary HART [®] variable is valid. Also checks if the selected measurement variable is available in this context and if its range is valid.
07	Tertiary HART variable	Checks if the tertiary HART [®] variable is valid.
08	Quaternary HART Variable	Checks if the measurement variable configured as quaternary HART [®] variable is valid.
09	Flow Totalizer	Checks if the measurement variable selected for the flow totalizer (volume flow, standard volume flow, mass flow) is valid. Also checks configuration of the HART [®] variables and local display.
10	Measurement Display Pages	Checks if the measurement variables are valid. If a bar graph is displayed its ranges are also checked.

Table 6-32: A12 plausibility checks

7.1 Replacing the signal converter / LC display

The signal converter has to be replaced by a signal converter of the same type.
The CG number ⑥ must match.

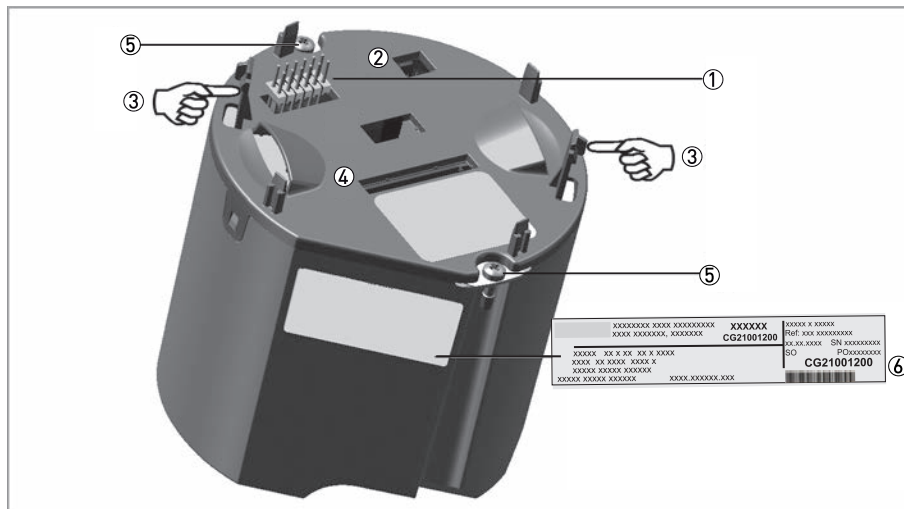

Figure 7-1: Connect the transmitter module

- ① Connector for LC display
- ② Service connector
- ③ Display brackets
- ④ Connection to the flow sensor
- ⑤ Fixing screw
- ⑥ CG number



The following steps are to be performed:

- Switch off the power supply.
- Unscrew the front cover with the key.
- Use the handle to pull out the display by plugging into the brackets ③ and gently pulling it out.
- Detach the flow sensor connection ④ .
- Loosen the two fixing screws ⑤ .
- Pull out the signal converter.
- Insert the new signal converter.
- Tighten the two screws ⑤ .
- Attach the flow sensor cable ④ .
- Attach display ① in desired position, apply even pressure to the entire surface.
- Screw on cover by hand.



INFORMATION!

*Use only spare parts that are unused and do not yet contain any configuration data.
Never connect components that contain data of two different devices!*

7.2 Maintaining the O-rings



Figure 7-2: Maintaining the O-rings

- ① Display cover
- ② Rear cover

Whenever either the display cover ① or the rear cover ② of the housing is opened and closed again, make sure that the O-rings are well greased or being replaced if need be (O-ring 94x2,5-NBR-70K, ISO 3601-1).



CAUTION!

Use proper multi-purpose grease covering the full operational temperature range to treat the O-rings with the following properties:

- Operational temperature range [-30...+130°C / -22...+266°F at permanent lubrication]
- Free from silicone
- Good adhesive capability
- Lithium saponified
- Water resistant
- Compatible with material of O-ring

7.3 Spare parts availability

The manufacturer adheres to the basic principle that functionally adequate spare parts for each device or each important accessory part will be kept available for a period of 3 years after delivery of the last production run for the device.

This regulation only applies to spare parts which are subject to wear and tear under normal operating conditions.

7.4 Availability of services

The manufacturer offers a range of services to support the customer after expiration of the warranty. These include repair, maintenance, technical support and training.



INFORMATION!

For more precise information, please contact your local sales office.

7.5 Returning the device to the manufacturer

7.5.1 General information

This device has been carefully manufactured and tested. If installed and operated in accordance with these operating instructions, it will rarely present any problems.



WARNING!

Should you nevertheless need to return a device for inspection or repair, please pay strict attention to the following points:

- *Due to statutory regulations on environmental protection and safeguarding the health and safety of the personnel, the manufacturer may only handle, test and repair returned devices that have been in contact with products without risk to personnel and environment.*
- *This means that the manufacturer can only service this device if it is accompanied by the following certificate (see next section) confirming that the device is safe to handle.*



WARNING!

If the device has been operated with toxic, caustic, radioactive, flammable or water-endangering products, you are kindly requested:

- *to check and ensure, if necessary by rinsing or neutralising, that all cavities are free from such dangerous substances,*
- *to enclose a certificate with the device confirming that it is safe to handle and stating the product used.*

7.5.2 Form (for copying) to accompany a returned device



CAUTION!

To avoid any risk for our service personnel, this form has to be accessible from outside of the packaging with the returned device.

Company:		Address:	
Department:		Name:	
Telephone number:		Email address:	
Fax number:			
Manufacturer order number or serial number:			
The device has been operated with the following medium:			
This medium is:	<input type="checkbox"/>	radioactive	
	<input type="checkbox"/>	water-hazardous	
	<input type="checkbox"/>	toxic	
	<input type="checkbox"/>	caustic	
	<input type="checkbox"/>	flammable	
	<input type="checkbox"/>	We checked that all cavities in the device are free from such substances.	
	<input type="checkbox"/>	We have flushed out and neutralized all cavities in the device.	
We hereby confirm that there is no risk to persons or the environment caused by any residual media contained in this device when it is returned.			
Date:		Signature:	
Stamp:			

7.6 Disposal



LEGAL NOTICE!

Disposal must be carried out in accordance with legislation applicable in your country.

Separate collection of WEEE (Waste Electrical and Electronic Equipment):



According to the directive 2012/19/EU or UK Regulation 2013 No. 3113, the monitoring and control instruments marked with the WEEE symbol and reaching their end-of-life **must not be disposed of with other waste.**

The user must dispose of the WEEE to a designated collection point for the recycling of WEEE or send them back to our local organisation or authorised representative.

7.7 Disassembly and recycling

This section describes (in short) the instructions of handling and disassembling the device when its reached end of live or is disposed of after usage. The information given is sufficient to gather the most important parts of the device (by the end-user) which can be used for recycling.

Product description - Vortex signal converter

Signal converter parts	Compact version	Remote version	Additional information
	[approx. kg / lb] ±5%		
Converter housing	1.081 / 2.383	2.378 / 5.243	Aluminium
Cover	0.2 / 0.441	0.6 / 1.323	Aluminium
Cover (window)	0.203 / 0.448	0.203 / 0.448	Aluminium, glass
Mounting adapter	0.48 / 1.058	1.44 / 3.175	Stainless steel
Wall mounting	-	0.857 / 1.889	Stainless steel
Additional parts	0.05 / 0.11	0.08 / 0.176	Stainless steel, galvanised steel, beryllium copper
Total weight	2.014 / 4.44	5.558 / 12.253	-

Table 7-1: Weight of metallic parts

Signal converter parts	Compact version	Remote version	Additional information
	[approx. kg / lb] ±5%		
Signal converter	0.478 / 1.054	0.478 / 1.054	Silicon: 57% PCB: 21% (196 cm ² / 30.4 inch ²) Polyamid: 20% Mixed metal: 2%
Assembly remote	-	0.057 / 0.126	PCB: 37% (47.3 cm ² / 7.3 inch ²) Silicon: 37% Polyamid: 26%
Wire feedthrough	0.053 / 0.117	0.105 / 0.231	Stainless steel: 80% Epoxid-Amin: 15% Copper: 5%
Terminal socket	0.103 / 0.227	0.103 / 0.227	Polyamid: 68% Stainless steel: 20% PCB: 12% (35 cm ² / 5.4 inch ²)
Remote terminals	-	0.094 / 0.207	Polyamid: 72% PCB: 28% (70 cm ² / 10.9 inch ²)
Pick-up	0.067 / 0.148	0.067 / 0.148	Stainless steel: 80% Epoxy: 13% Ceramic: 5% Copper: 2%
Cable (10 m / 32.8 ft)	-	0.68 / 1.499	-
Total weight	0.701 / 1.545	1.584 / 3.4922	-

Table 7-2: Weight of mixed materials parts

Signal converter parts	Compact version	Remote version	Additional information
	[approx. kg / lb] ±5%		
Cable gland	0.011 / 0.024	0.022 / 0.049	Polyamid
Blind plug	0.006 / 0.013	0.012 / 0.026	Polyamid or stainless steel; depending on Ex option
Dubox connectors	0.002 / 0.004	0.0035 / 0.008	Thermoplastic glass filled
Total weight	0.019 / 0.042	0.0375 / 0.083	-

Table 7-3: Weight of plastic parts

**INFORMATION!**

*The product does not contain harmful gases or liquids.
The percentage of hazardous substances present in the components comply with RoHS.*

**DANGER!**

*The device **MUST** be disconnected from mains power before disassembling.*

**CAUTION!**

Before disassembling the device:

- *Make sure you have the proper tools needed.*
- *Allen key set*
- *Phillips head screwdriver PH 1-2*
- *Torx screwdriver TX 10*
- *(Adjustable) wrench 16 / 30-32 mm*
- *Circlip pliers*

**INFORMATION!**

- *Wear personal protective equipment.*
- *Make sure you use a steady workplace/bench to do the disassembly actions.*

7.7.1 Disassembly of the compact signal converter unit



- By unscrewing of the four hexagon socket screws, the signal converter housing can also be separated from the flow sensor.
- Remove all the covers ② on the housing and console by unscrewing.
Non standard versions can have interlocking headscrews which then have to be unscrewed first with Allen key 2.5.
- Disconnect all electric cables from connection terminals (if still attached).
- Remove all the cable glands, stopping plug and plastic insert of the housing ① .
- Remove the display ③ .
- Plug off the blue Dubox plug from the electronic.
- Loosen the 2 screws with a phillips head screwdriver PH 1-2.
- Pull out the electronic insert ④ .
- Unscrew the backplane PCB with terminal block ⑤ inside of the electronic housing ① with a TX 10 screwdriver.
- Remove the circlip inside of the electronic housing ① from the backplane PCB with terminal block with a circlip pliers.
- Remove the terminal block from the back side of the signal converter housing.
- Unscrew the electrical feedthrough ⑥ from the signal converter housing.
- ➔ All main parts are now disassembled and can be shipped separate for re-usage and/or recycling.

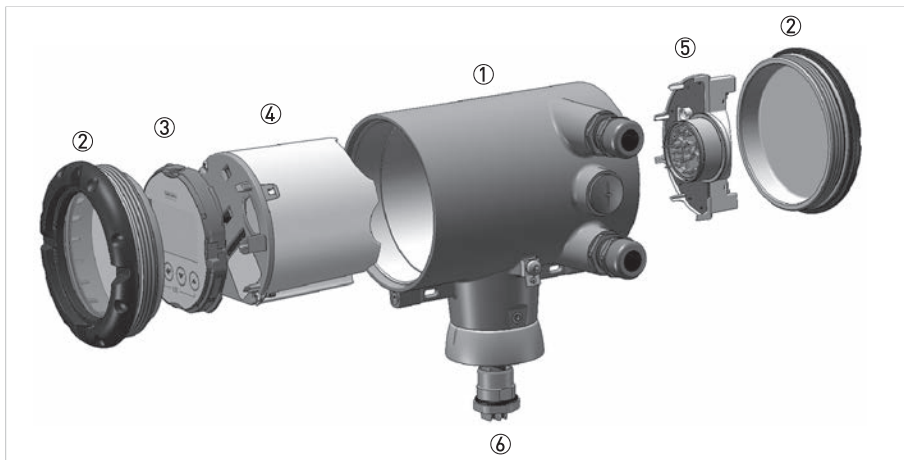

Figure 7-3: Exploded view of the compact signal converter unit

- ① Signal converter housing
- ② Front and back cover
- ③ Display unit
- ④ Electronic insert
- ⑤ Backplane PCB with terminal block
- ⑥ Electrical feedthrough

7.7.2 Disassembly of the remote signal converter unit



Wall mounting bracket side

- The complete signal converter unit ① can be dismantled as described for the compact version.
 - Disconnect all wires of the remote cable from the terminal block and grounding connection (if still attached).
 - Unscrew the connection terminal block ⑤ with a TX 10 screwdriver.
 - Plug off the blue Dubox plugs from the backside of the terminal block.
 - By unscrewing of the four hexagon socket screws ②, the junction box housing ③ can also be separated from the wall mounting bracket ④.
 - By unscrewing of the four hexagon socket screws ②, the signal converter housing ① and the wall mounting bracket ④ can also be separated.
- ➡ All main parts are now disassembled and can be shipped separate for re-usage and/or recycling.

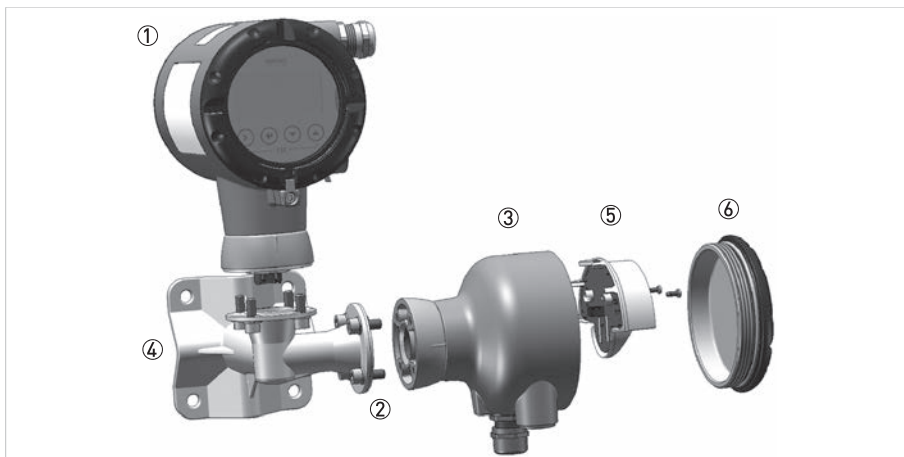

Figure 7-4: Exploded view of the remote signal converter unit

- ① Signal converter unit
- ② Hexagon socket screws
- ③ Junction box housing
- ④ Wall mounting bracket
- ⑤ Connection terminal block
- ⑥ Cover of connection box



Flow sensor side

- By unscrewing of the four hexagon socket screws, the sensor connection box housing ① can also be separated from the flow sensor.
- Remove the cover ② on the housing by unscrewing. Non standard versions can have interlocking headscrews which then have to be unscrewed first with Allen key 2.5.
- Disconnect all wires of the remote cable from the terminal block and grounding connection (if still attached).
- Remove all the cable glands, stopping plug and plastic insert of the sensor connection box housing ① .
- Unscrew the connection terminal block ③ with a TX 10 screwdriver.
- Plug off the blue Dubox plug from the sensor electronics.
- Remove the sensor electronics with terminal block ③ from the sensor connection box housing.
- Unscrew the electrical feedthrough ④ from the signal converter housing.
- ➡ All main parts are now disassembled and can be shipped separate for re-usage and/or recycling.



Figure 7-5: Exploded view of remote sensor connection box

- ① Sensor connection box housing
- ② Cover of electric and I/O connections compartment
- ③ Sensor electronics with terminal block
- ④ Feedthrough

8.1 Functional principle

Vortex flowmeters are used to measure the flow of gases, vapours and liquids at completely filled pipes.

The measuring principle is based on the Karman vortex street. The measuring tube contains a bluff body at which vortex shedding occurs and which is detected by a sensor unit located behind. The frequency f of the vortex shedding is proportional to the flow velocity v . The non-dimensional Stouhal number S describes the relationship between vortex frequency f , width b of the bluff body and the average flow velocity v :

$$f = \frac{S \cdot v}{b}$$

The vortex frequency is recorded at the flow sensor and evaluated at the signal converter.

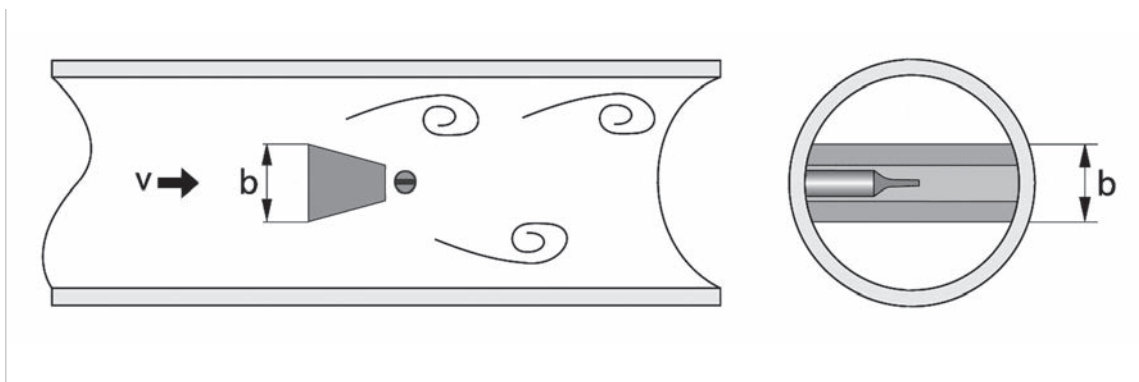

Figure 8-1: Functional principle

8.2 Technical data



INFORMATION!

- The following data is provided for general applications. If you require data that is more relevant to your specific application, please contact us or your local sales office.
- Additional information (certificates, special tools, software,...) and complete product documentation can be downloaded free of charge from the website (Downloadcenter).

Measuring system

Application range	Flow measurement of liquids, gases and vapours
Function / Measuring principle	Karman vortex street
Measurement	
Primary measured value	Number of separated vortices
Secondary measured value	Operating and standard volume flow and mass flow
Signal converter	
Versions	Compact version
	Remote version
Weather protection cover	Optional available cover to protect the signal converter housing against intense solar radiation or vandalism
Flow sensor	
Standard	Flange version, flow sensor: F
	Sandwich version, flow sensor: S
Option	Flange version with single reduction of nominal diameter, flow sensor: F1R
	Flange version with double reduction of nominal diameter, flow sensor: F2R
Display and user interface	
Local display	Graphic display
Interface and display languages	Available display languages: German, English, French, Italian, Spanish, Chinese, Czech, Polish, Turkish
Communication interfaces	HART®

Measuring accuracy

Reference condition	
Reference conditions	Water at +20°C / +68°F
	Air at +20°C / +68°F and 1.013 bara / 14.7 psia
Maximum measuring error	
Flow rate (liquid)	±1% of measured value (Re ≥ 20000) with calibration
	±5% of measured value (Re ≥ 20000) without calibration
	±3% of measured value (10000 < Re < 20000) with calibration
	±7% of measured value (10000 < Re < 20000) without calibration
Flow rate (gases and steam)	±2% of measured value (Re ≥ 20000) with calibration
	±5% of measured value (Re ≥ 20000) without calibration
	±3% of measured value (10000 < Re < 20000) with calibration
	±7% of measured value (10000 < Re < 20000) without calibration
Repeatability (volume flow)	±0.1% of measured value

Operating conditions

Temperature	
Medium temperature	-40...+240°C / -40...+465°F
Ambient temperature ②	Non-Ex: -40...+85°C / -40...+185°F
	Ex: -40...+65°C / -40...+140°F
Storage temperature	-40...+85°C / -40...+185°F
② Decreasing display contrast outside of the temperature range of 0...+60°C / +32...+140°F.	
Pressure	
Medium pressure	Max. 100 bar / 1450 psi
Ambient pressure	Atmosphere: altitude up to 4000 m / 13123 ft above sea level
Media properties	
Density	Taken into consideration when sizing.
Viscosity	< 10 cP
Reynold's number	> 10000
Other conditions	
Use	Indoor / Outdoor
Humidity	Annual average ≤ 90% RH (no condensation)

Recommended flow velocities	
Liquids ③	0.3...7 m/s / 0.98...23 ft/s (optional up to 10 m/s / 32.8 ft/s taking cavitation into account)
Gases and steam ③	2.0...80 m/s / 6.6...262.5 ft/s
	DN15: 3.0...45 m/s / 9.8...148 ft/s; DN25: 2.0...70 m/s / 6.6...230 ft/s
③ These values represent the absolute limits of flow velocities. For more detailed information for your specific application refer to <i>Intended use</i> on page 7.	
Other conditions	
Ingress protection	Compact version: IP66/67
	Remote version: signal converter housing: IP66/67; flow sensor housing: IP66/67

Installation conditions

Inlet section	≥ 15 DN without disturbing flow
	≥ 20 DN after a pipe diameter reduction
	≥ 20 DN after a single bend 90°
	≥ 30 DN after a double bend 2 x 90°
	≥ 40 DN after a double three-dimensional bend 2 x 90°
	≥ 50 DN after a control valve
	≥ 2 DN before a flow straightener; ≥ 8 DN after a flow straightener
Outlet section	≥ 5 x DN

Materials

Flanges and process connections	Steel A105
Flow sensor body	Die-cast stainless steel 1.4408/CF8M
Electronics housing	Die-cast aluminium, two-layer coating (epoxy/polyester)
Measuring tube (Pick-up gasket)	Stainless steel 1.4435 / 316L

Process connections

Flange version	
DIN EN 1092-1	DN15...100, PN16...100 DN150...300, PN16...40
ASME B16.5	NPS1/2...4, 150...600 lb NPS6...12, 150...300 lb
JIS B2220	DN15...300, 10...20 K
For detailed information on combination flange/pressure rating, refer to section "Dimensions and weights".	
Sandwich version	
DIN	DN15...100, PN100
ASME	NPS1/2...4, 600 lb
JIS	DN15...100, 10...20 K

Electrical connections

Power supply (current output version)	The power supply has to be able to supply a minimum of 22 mA.
	Non-Ex: 12...36 VDC
	Ex i: 12...30 VDC
	Ex d: 12...32 VDC
Connection terminals	For wire cross-sections 0.5...2.5 mm ²
	Fastening torque: 0.6 N
Cable entries	Standard: M20.5
	Option: 1/2 NPT and G1/2 adapters
Connecting cable	Only for remote versions.
	Cable length: ≤ 50 m / 164 ft

Outputs

General	All inputs and outputs are electrically isolated from each other and from all other circuits.
Time constant	The time constant corresponds to 63% of the elapsed time of a processor procedure. 0...100 seconds (rounded up to 0.1 seconds)
Current output	
Type	4...20 mA HART [®] (passive)
Output data	Volume flow, mass flow, norm. volume flow, vortex frequency, flow velocity
Resolution	5 μA
Linearity / accuracy	0.1% (of read value)
Temperature coefficient	50 ppm/K (typically), 100 ppm/K (max.)
Error signal	According to NE 43
Description of abbreviations	U_{ext} = external voltage; R_L = load + resistance
Load	Minimum 0 Ω; maximum $R_L = ((U_{ext} - 12 \text{ VDC}) / 22 \text{ mA})$
HART[®]	
General	HART [®] protocol via passive current output
HART [®] revision	HART [®] 7
	Burst mode
System requirements	Load min. 250 Ω
Multidrop operation	4 mA

Pulse output	
Type	Passive
Temperature coefficient	50 ppm/K
Residual current	< 0.2 mA at 32 V ($R_i = 180 \text{ k}\Omega$)
Pulse width	0.5...2000 ms
Output data	Volume, mass, norm. volume
Pulse rate	Max. 1000 pulses/s
Power supply	Non-Ex: 24 VDC as NAMUR or open < 1 mA, maximum 36 V, closed 120 mA, $U < 2 \text{ V}$ Ex: 24 VDC as NAMUR or open < 1 mA, maximum 30 V, closed 120 mA, $U < 2 \text{ V}$

Approvals and certificates

Declaration of conformity	This device fulfils the statutory requirements of the relevant directives and regulations. The manufacturer certifies successful testing of the product by applying the conformity mark on the device. For further information on directives, regulations, standards and certifications, please refer to the declaration of conformity which you can download from the manufacturer's website.
Standard version	Non-Ex
Hazardous areas	
ATEX	ATEX II2 G - Ex ia IIC T6...T2 Gb ATEX II2 G - Ex d ia IIC T6...T2 Gb ATEX II2 D - Ex tb IIIC T70°C Db
IECEX	IECEX - Ex ia IIC T6...T2 Gb IECEX - Ex d ia IIC T6...T2 Gb IECEX - Ex tb IIIC T70°C Db
QPS (USA & Canada)	QPS IS Class I Div 1 QPS XP Class I Div 1 QPS DIP Class II, III Div 1
Other standards and approvals	
QPS (USA & Canada)	QPS Ordinary Locations
Mechanical stress tests: Stationary vibration and shock	The signal converter was tested according to IEC 60721-3-4 Class 4M4. The flow sensor was tested according to IEC 60721-3-4 Class 4M4 and IEC 61298-3 - Low vibration. Sine vibration test - endurance (IEC 61298-3 - Low vibration, IEC 60068-2-6) - Frequency range: 10...1000 Hz - Amplitude: 10.0...58.1 Hz: $\pm 0.15 \text{ mm}$; 58.1...1000.0 Hz: 20 m/s^2 Sine vibration test - class 4M4 (IEC 60721-3-4 Class 4M4, IEC 60068-2-6) - Frequency range: 5...200 Hz - Amplitude: 5.00...8.51 Hz: $\pm 3.5 \text{ mm}$; 8.51...200.0 Hz: 10 m/s^2 Mechanical shock test (IEC 60721-3-4 Class 4M4, IEC 60068-2-27) - Shock pulse: Half-sine - Shock acceleration: 15g - Shock duration: 6 ms
NAMUR	NE 06, NE 21, NE 23, NE 32, NE 43, NE 53, NE 107
Further approvals on request.	

Table 8-1: Technical data

8.3 Dimensions and weights

8.3.1 Flange versions

Flange version EN 1092-1

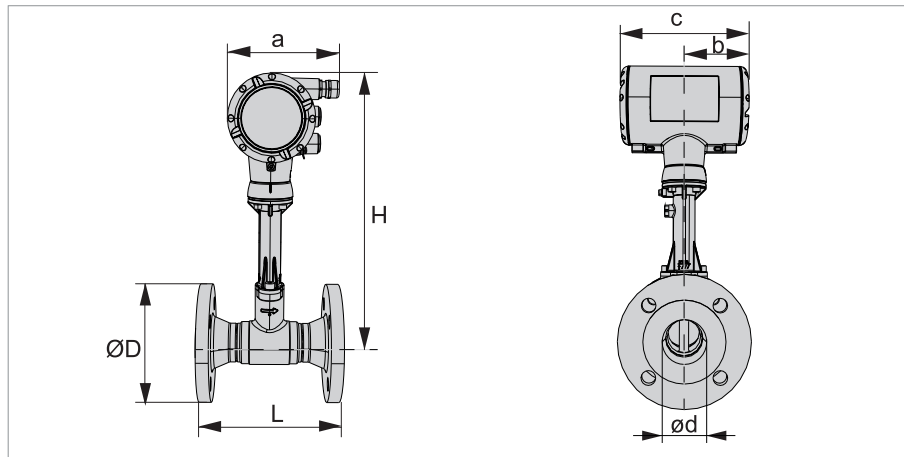

Figure 8-2: Front and side view of flange version

a = 148.5 mm / 5.85"

b = 85.8 mm / 3.38"

c = 171.5 mm / 6.75"

F1R - single reduction

F2R - double reduction

Nominal size	Pressure rating	Dimensions [mm]						Weight [kg]				
		DN	PN	d	D	L	H	H F1R	H F2R	Std.	F1R	F2R
15	40	15	40	17.3	95	200	358.2	-	-	5.3	-	-
15	100	15	100	17.3	105	200	358.2	-	-	6.1	-	-
25	40	25	40	28.5	115	200	358.2	358.2	-	6.4	6.5	-
25	100	25	100	28.5	140	200	358.2	358.2	-	9.0	9.0	-
40	40	40	40	43.1	150	200	363.3	358.2	358.2	8.4	8.2	8.2
40	100	40	100	42.5	170	200	363.3	358.2	358.2	12.1	11.9	11.8
50	16	50	16	54.5	165	200	367.3	363.3	358.2	9.5	9.2	9.2
50	40	50	40	54.5	165	200	367.3	363.3	358.2	10.1	9.7	9.8
50	63	50	63	54.5	180	200	367.3	363.3	358.2	13.5	12.9	12.8
50	100	50	100	53.9	195	200	367.3	363.3	358.2	15.8	15.2	15.1
80	16	80	16	82.5	200	200	393.8	367.3	363.3	13.5	12.8	12.1
80	40	80	40	82.5	200	200	393.8	367.3	363.3	14.9	14.2	13.5
80	63	80	63	81.7	215	200	393.8	367.3	363.3	15.3	17.8	16.9
80	100	80	100	80.9	230	200	393.8	367.3	363.3	22.4	21.5	20.7
100	16	100	16	107.1	220	250	407.3	393.8	367.3	17.5	17.1	15.7
100	40	100	40	107.1	235	250	407.3	393.8	367.3	21.1	20.7	19.2

Nominal size	Pressure rating	Dimensions [mm]						Weight [kg]		
		DN	PN	d	D	L	H	H F1R	H F2R	Std.
100	63	106.3	250	250	407.3	393.8	367.3	27.6	27.0	25.0
100	100	104.3	265	250	407.3	393.8	367.3	35.8	33.3	31.6
150	16	159.3	285	300	416.3	407.3	393.8	26.6	29.0	27.4
150	40	159.3	300	300	416.3	407.3	393.8	34.0	37.3	35.4
200	10	206.5	340	300	442.1	416.3	407.3	39.1	37.4	34.6
200	16	206.5	340	300	442.1	416.3	407.3	38.7	37.0	35.0
200	25	206.5	360	300	442.1	416.3	407.3	47.6	47.8	46.4
200	40	206.5	375	300	442.1	416.3	407.3	54.6	55.1	54.1
250	10	260.4	395	380	468.8	442.1	416.3	59.6	61.7	54.8
250	16	260.4	405	380	468.8	442.1	416.3	61.2	63.3	56.5
250	25	258.8	425	380	468.8	442.1	416.3	72.7	76.0	71.8
250	40	258.8	450	380	468.8	442.1	416.3	91.6	94.2	90.7
300	10	309.7	445	450	492.8	468.8	442.1	80.8	81.8	83.3
300	16	309.7	460	450	492.8	468.8	442.1	87.2	88.3	90.4
300	25	307.9	485	450	492.8	468.8	442.1	103.4	104.5	108.6
300	40	307.9	515	450	492.8	468.8	442.1	131.7	132.2	141.6

Table 8-2: Dimensions and weight of flange version EN 1092-1 in mm and kg

Nominal size	Pressure rating	Dimensions [inch]						Weight [lb]		
		DN	PN	d	D	L	H	H F1R	H F2R	Std.
15	40	0.7	3.7	7.9	14.1	-	-	11.7	-	-
15	100	0.7	4.1	7.9	14.1	-	-	13.4	-	-
25	40	1.1	4.5	7.9	14.1	14.1	-	14.1	14.3	-
25	100	1.1	5.5	7.9	14.1	14.1	-	19.8	19.8	-
40	40	1.7	5.9	7.9	14.3	14.1	14.1	18.5	18.1	18.1
40	100	1.67	6.7	7.9	14.3	14.1	14.1	26.7	26.2	26.0
50	16	2.14	6.5	7.9	14.5	14.3	14.1	20.9	20.3	20.3
50	40	2.14	6.5	7.9	14.5	14.3	14.1	22.3	21.4	21.6
50	63	2.14	7.1	7.9	14.5	14.3	14.1	29.8	28.4	28.2
50	100	2.12	7.3	7.9	14.5	14.3	14.1	34.8	33.5	33.3
80	16	3.25	7.9	7.9	15.5	14.5	14.3	29.8	28.2	26.7
80	40	3.25	7.9	7.9	15.5	14.5	14.3	32.8	31.3	29.8
80	63	3.2	8.5	7.9	15.5	14.5	14.3	33.7	39.2	37.2
80	100	3.18	9.1	7.9	15.5	14.5	14.3	49.4	47.4	45.6
100	16	4.2	8.7	9.8	16.0	15.5	14.5	38.6	37.7	34.6
100	40	4.2	9.3	9.8	16.0	15.5	14.5	46.5	45.6	42.3

Nominal size	Pressure rating	Dimensions [inch]						Weight [lb]		
		DN	PN	d	D	L	H	H F1R	H F2R	Std.
100	63	4.18	9.8	9.8	16.0	15.5	14.5	60.8	59.5	55.1
100	100	4.1	10.4	9.8	16.0	15.5	14.5	78.9	73.4	69.7
150	16	6.3	11.2	11.8	16.4	16.0	15.5	58.6	63.9	60.4
150	40	6.3	11.8	11.8	16.4	16.0	15.5	75.0	82.2	78.0
200	10	8.1	13.4	11.8	17.4	16.4	16.0	86.2	82.5	76.3
200	16	8.1	13.4	11.8	17.4	16.4	16.0	85.3	81.6	77.2
200	25	8.1	14.2	11.8	17.4	16.4	16.0	104.9	105.4	102.3
200	40	8.1	14.8	11.8	17.4	16.4	16.0	120.4	121.5	119.3
250	10	10.3	15.6	15.0	18.5	17.4	16.4	131.4	136.0	120.8
250	16	10.3	15.9	15.0	18.5	17.4	16.4	134.9	139.6	124.6
250	25	10.2	16.7	15.0	18.5	17.4	16.4	160.3	167.6	158.3
250	40	10.2	17.7	15.0	18.5	17.4	16.4	201.9	207.7	200.0
300	10	12.2	17.5	17.7	19.4	18.5	17.4	178.1	180.3	183.6
300	16	12.2	18.1	17.7	19.4	18.5	17.4	192.2	194.7	199.3
300	25	12.1	19.1	17.7	19.4	18.5	17.4	228.0	230.4	239.4
300	40	12.1	20.3	17.7	19.4	18.5	17.4	290.3	291.4	312.2

Table 8-3: Dimensions and weight of flange version EN 1092-1 in inch and lb

Flange version ASME B16.5

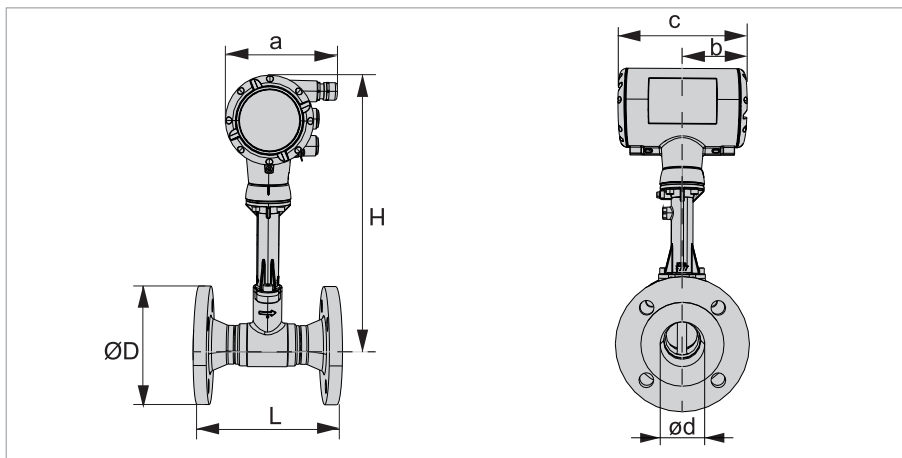

Figure 8-3: Front and side view of flange version

a = 148.5 mm / 5.85"

b = 85.8 mm / 3.38"

c = 171.5 mm / 6.75"

Nominal size	Pressure rating	Dimensions [mm]						Weight [kg]		
		NPS	Class	d	D	L	H	H F1R	H F2R	Std.
1/2	150	15.8	90	200	358.2	-	-	4.7	-	-
1/2	300	15.8	95	200	358.2	-	-	5.2	-	-
1/2	600	15.8	95	200	358.2	-	-	5.3	-	-
1	150	26.6	110	200	358.2	358.2	-	5.8	5.8	-
1	300	26.6	125	200	358.2	358.2	-	6.8	6.9	-
1	600	24.3	125	200	358.2	358.2	-	7.2	7.2	-
1 1/2	150	40.9	125	200	363.3	358.2	358.2	7.2	7.1	7.0
1 1/2	300	40.9	155	200	363.3	358.2	358.2	9.5	9.4	9.3
1 1/2	600	38.1	155	200	363.3	358.2	358.2	10.5	10.4	10.4
2	150	52.5	150	200	367.3	363.3	358.2	9.2	9.1	8.8
2	300	52.5	165	200	367.3	363.3	358.2	10.8	10.7	10.4
2	600	49.2	165	200	367.3	363.3	358.2	12.5	12.3	12.0
3	150	77.9	190	200	393.8	367.3	363.3	14.7	14.1	13.7
3	300	77.9	210	200	393.8	367.3	363.3	18.0	17.7	17.4
3	600	74.0	210	200	393.8	367.3	363.3	21.0	20.6	20.3
4	150	102.3	230	250	407.3	393.8	367.3	20.9	21.0	19.9
4	300	102.3	255	250	407.3	393.8	367.3	29.4	29.6	28.5
4	600	97.2	275	250	407.3	393.8	367.3	40.9	40.8	39.8
6	150	154.1	280	300	416.3	407.3	393.8	29.9	33.3	32.1
6	300	154.1	320	300	416.3	407.3	393.8	47.4	52.2	51.1
8	150	202.7	345	300	442.1	416.3	407.3	45.6	45.7	45.5
8	300	202.7	380	300	442.1	416.3	407.3	66.2	69.4	71.6

Nominal size	Pressure rating	Dimensions [mm]						Weight [kg]		
		NPS	Class	d	D	L	H	H F1R	H F2R	Std.
10	150	254.6	405	380	468.8	442.1	416.3	68.2	73.8	69.1
10	300	254.6	455	380	468.8	442.1	416.3	106.3	111.4	111.2
12	150	304.8	485	450	492.8	468.8	442.1	110.7	111.0	118.0
12	300	304.8	520	450	492.8	468.8	442.1	154.8	153.6	170.5

Table 8-4: Dimensions and weight of flange version ASME B16.5 in mm and kg

Nominal size	Pressure rating	Dimensions [inch]						Weight [lb]		
		NPS	Class	d	D	L	H	H F1R	H F2R	Std.
1/2	150	0.6	3.5	7.9	14.1	-	-	10.4	-	-
1/2	300	0.6	3.7	7.9	14.1	-	-	11.5	-	-
1/2	600	0.6	3.7	7.9	14.1	-	-	11.7	-	-
1	150	1.0	4.3	7.9	14.1	14.1	-	12.8	12.8	-
1	300	1.0	4.9	7.9	14.1	14.1	-	15.0	15.2	-
1	600	0.96	4.9	7.9	14.1	14.1	-	15.9	15.9	-
1 1/2	150	1.6	4.9	7.9	14.3	14.1	14.1	15.9	15.7	15.4
1 1/2	300	1.6	6.1	7.9	14.3	14.1	14.1	20.9	20.7	20.5
1 1/2	600	1.5	6.1	7.9	14.3	14.1	14.1	23.1	22.9	22.9
2	150	2.1	5.9	7.9	14.5	14.3	14.1	20.3	20.1	19.4
2	300	2.1	6.5	7.9	14.5	14.3	14.1	23.8	23.6	22.9
2	600	1.9	6.5	7.9	14.5	14.3	14.1	27.6	27.1	26.5
3	150	3.1	7.5	7.9	15.5	14.5	14.3	32.4	31.1	30.2
3	300	3.1	8.3	7.9	15.5	14.5	14.3	39.7	39.0	38.4
3	600	2.9	8.3	7.9	15.5	14.5	14.3	46.3	45.4	44.8
4	150	4.0	9.1	9.8	16.0	15.5	14.5	46.1	46.3	43.9
4	300	4.0	10.0	9.8	16.0	15.5	14.5	64.8	65.3	62.8
4	600	3.8	10.8	9.8	16.0	15.5	14.5	90.2	89.9	87.7
6	150	6.1	11.0	11.8	16.4	16.0	15.5	65.9	73.4	70.8
6	300	6.1	12.6	11.8	16.4	16.0	15.5	104.5	115.1	112.7
8	150	8.0	13.6	11.8	17.4	16.4	16.0	100.5	100.8	100.3
8	300	8.0	14.2	11.8	17.4	16.4	16.0	145.9	153.0	157.9
10	150	10.1	15.9	15.0	18.5	17.4	16.4	150.4	162.7	152.3
10	300	10.1	17.5	15.0	18.5	17.4	16.4	234.4	245.6	245.2
12	150	12	19.1	17.7	19.4	18.5	17.4	244.1	244.7	260.1
12	300	12	20.5	17.7	19.4	18.5	17.4	341.3	338.6	375.9

Table 8-5: Dimensions and weight of flange version ASME B16.5 in inch and lb

8.3.2 Sandwich versions

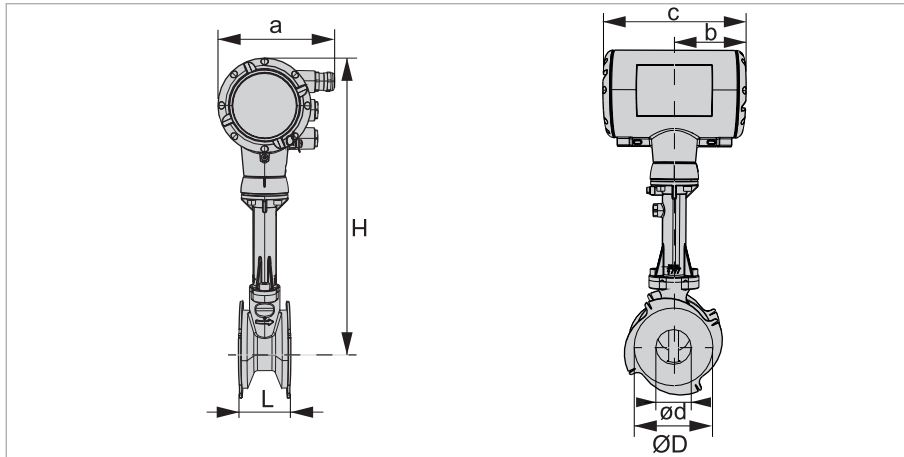

Figure 8-4: Front and side view of sandwich version

a = 148.5 mm / 5.85"
 b = 85.8 mm / 3.38"
 c = 171.5 mm / 6.75"

Nominal size	Pressure rating	Dimensions [mm]				Weight [kg]
		DN	PN	d	D	
15	100	16	41	65	358.2	3.9
25	100	24	61	65	358.2	4.2
40	100	36	78	65	363.3	4.6
50	100	44	98	65	367.3	5.2
80	100	73	131	65	393.8	6.7
100	100	90	154	65	407.3	7.9

Table 8-6: Dimensions and weight of sandwich version in mm and kg

Nominal size	Pressure rating	Dimensions [inch]				Weight [lb]
		DN	PN	d	D	
15	100	0.6	1.6	2.6	14.1	8.6
25	100	0.9	2.4	2.6	14.1	9.3
40	100	1.4	3.1	2.6	14.3	10.1
50	100	1.7	3.8	2.6	14.5	11.5
80	100	2.9	5.2	2.6	15.5	14.8
100	100	3.5	6.1	2.6	16.0	17.4

Table 8-7: Dimensions and weight of sandwich version in inch and lb

8.3.3 Remote versions

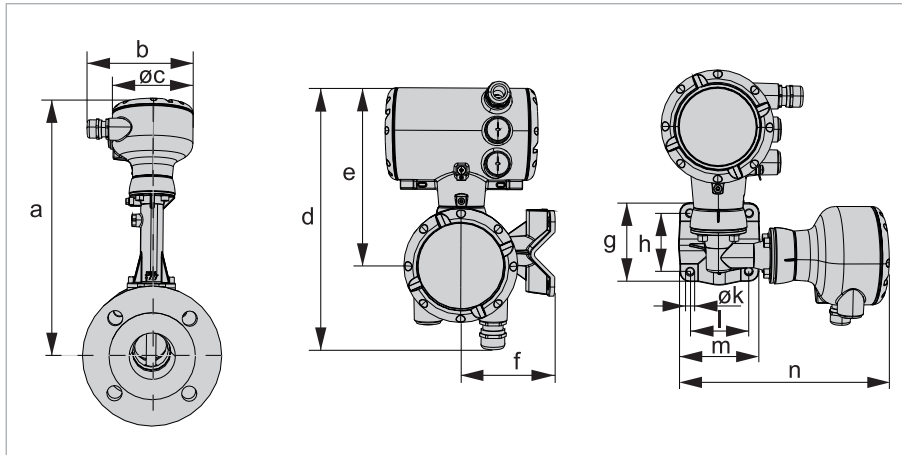

Figure 8-5: Front and side view of remote version

Dimension a

	Flange & sandwich version						Flange version			
DN	15	25	40	50	80	100	150	200	250	300
NPS	1/2	1	1 1/2	2	3	4	6	8	10	12
[mm]	314.6	314.6	319.7	323.7	350.2	363.7	372.7	398.5	425.2	449.2
["]	12.4	12.4	12.6	12.7	13.8	14.3	14.7	15.7	16.7	17.7

Table 8-8: Dimension a in mm and inch

Dimension a F1/2R

	Flange version									
DN	15	25	40	50	80	100	150	200	250	300
NPS	1/2	1	1 1/2	2	3	4	6	8	10	12
F1R [mm]	-	314.6	314.6	319.7	323.7	350.2	363.7	372.7	398.5	425.2
["]	-	12.4	12.4	12.6	12.7	13.8	14.3	14.7	15.7	16.7
F2R [mm]	-	-	314.6	314.6	319.7	323.7	350.2	363.7	372.7	398.95
["]	-	-	12.4	12.4	12.6	12.7	13.8	14.3	14.7	15.7

Table 8-9: Dimension a for F1R and F2R in mm and inch

Dimensions b...n

	b	c	d	e	f	g	h	j	k	l	m	n
[mm]	138.5	108.0	275.6	191.2	105.0	97.0	72.0	108.0	9.0	72.0	97.0	226.0
["]	5.46	4.25	10.9	7.53	4.14	3.82	2.84	4.25	0.35	2.84	3.82	8.90

Table 8-10: Dimensions b...n in mm and inch

8.4 Flow tables

Nominal size		Q_{\min}	Q_{\max}	Q_{\min}	Q_{\max}
DN - EN 1092-1	NPS - ASME B16.5	[m ³ /h]		[gph]	

Water

15	1/2	0.36	5.04	95.61	1283
15C	1/2	0.36	5.04	95.61	1283
25	1	0.81	11.34	215	3012
25C	1	0.81	11.34	215	3012
40	1 1/2	1.83	25.52	486.02	6256
50	2	2.74	38.13	727.70	10127
80	3	7.53	104.90	2000	27860
100	4	11.45	159.50	3041	42361
150	6	30.13	419.80	7961	111492
200	8	56.55	787.70	15019	209200
250	10	90.49	1261	23905	334901
300	12	123.03	1714	32675	455210

Values based on water at +20°C / +68°F

Air

15	1/2	4.34	32.4	1147	8605
15C	1/2	8.69	39.6	2297	10517
25	1	9.77	113.4	2582	30117
25C	1	19.54	129.6	5164	34420
40	1 1/2	21.99	291.7	5812	77471
50	2	32.84	435.7	8679	115715
80	3	90.40	1199	23891	318434
100	4	137.41	1823	36316	484158
150	6	361.6	4797	95532	1274003
200	8	678.58	9003	179339	2391047
250	10	1086	14406	286870	3825993
300	12	1476	19586	390176	5201715

Values based on air at +20°C / +68°F and 1.013 bara / 14.7 psia and density 1.204 kg/m³ / 0.0751 lb/ft³

Table 8-11: Measuring ranges for water and air

Gauge pressure [barg]		1		3.5		5.2		7	
Density [kg/m ³]		1.134		2.419		3.272		4.166	
Temperature [°C]		120.4		148.0		160.2		170.5	
Flow rate		min.	max.	min.	max.	min.	max.	min.	max.
DN EN 1092-1	NPS ASME B16.5	[kg/h]		[kg/h]		[kg/h]		[kg/h]	
15	1/2	5.87	36.79	7.41	78.41	8.62	106.0	9.73	135.0
25	1	11.43	128.7	16.68	274.4	19.4	371.1	21.89	472.5
40	1 1/2	25.71	331.1	37.53	705.7	43.64	954.4	49.24	1215
50	2	38.4	494.6	56.06	1054	65.2	1425	73.56	1815
80	3	105.7	1361	154.4	2901	179.5	3924	202.5	4996
100	4	160.7	2069	234.6	4410	272.8	5965	307.8	7594
150	6	422.8	5446	617.3	11607	717.8	15698	809.9	19985
200	8	793.4	10220	1159	21781	13487	29458	1520	37503
250	10	1270	16355	1854	33855	2156	47139	2432	60014
300	12	1727	22236	2520	47388	2931	64089	3307	81594

Table 8-12: Measuring range for saturated steam: 1...7 barg

Gauge pressure [barg]		10.5		14		17.5		20	
Density [kg/m ³]		5.883		7.588		9.304		10.53	
Temperature [°C]		186.1		198.3		208.5		214.9	
Flow rate		min.	max.	min.	max.	min.	max.	min.	max.
DN EN 1092-1	NPS ASME B16.5	[kg/h]		[kg/h]		[kg/h]		[kg/h]	[kg/h]
15	1/2	12.78	190.6	16.49	246.0	20.21	301.5	22.87	341.3
25	1	26.01	667.2	29.55	853.0	32.71	950.0	34.8	1014
40	1 1/2	58.52	1676	66.48	1919	73.6	2137	78.29	2282
50	2	87.41	2504	99.31	2867	110.0	3193	117.0	3409
80	3	240.6	6893	273.4	7891	302.6	8789	322.0	9385
100	4	365.8	10477	415.5	11995	460.0	13360	489.4	14266
150	6	962.4	27572	1094	31567	1211	35158	1288	37542
200	8	1808	51741	2052	59237	2272	65975	2417	70450
250	10	2890	82797	3284	94792	3635	105576	3867	112736
300	12	3930	112569	4464	128877	4942	143538	5258	153273

Table 8-13: Measuring range for saturated steam: 10.5...20 barg

Gauge pressure [psig]		15		50		75		100	
Density [lb/ft ³]		0.0722		0.1494		0.2034		0.2564	
Temperature [°F]		249.8		297.7		320.0		337.8	
Flow rate		min.	max.	min.	max.	min.	max.	min.	max.
DN EN 1092-1	NPS ASME B16.5	[lb/h]		[lb/h]		[lb/h]		[lb/h]	[lb/h]
15	1/2	12.32	82.42	16.26	171.1	18.97	232.8	21.31	293.8
25	1	25.40	288.4	36.59	598.8	42.58	814.9	47.95	1028
40	1 1/2	57.14	741.8	82.32	1540	96.03	2095	107.9	2644
50	2	85.35	1108	123.0	2300	143.5	3130	161.2	3951
80	3	235.0	3050	338.5	6332	394.9	8616	443.6	10875
100	4	357.1	4636	514.5	9625	600.2	13097	674.3	16531
150	6	939.7	12056	1354	25329	1580	34467	1775	43503
200	8	1764	22531	2541	47530	2964	64679	3330	81634
250	10	2822	36638	4066	76060	4743	103501	5329	130634
300	12	3837	49812	5528	103409	6448	140717	7244	177606

Table 8-14: Measuring range for saturated steam: 15...100 psig

Gauge pressure [psig]		150		200		250		300	
Density [lb/ft ³]		0.3624		0.4676		0.5728		0.6784	
Temperature [°F]		365.9		387.8		406.0		421.8	
Flow rate		min.	max.	min.	max.	min.	max.	min.	max.
DN EN 1092-1	NPS ASME B16.5	[lb/h]		[lb/h]		[lb/h]		[lb/h]	[lb/h]
15	1/2	27.80	414.4	35.87	535.3	43.94	655.7	52.04	776.6
25	1	56.97	1452	64.71	1867	71.62	2079	78.06	2274
40	1 1/2	128.2	3670	145.6	4201	162.3	4768	175.67	5117
50	2	191.5	5483	217.5	6276	240.8	6989	262.4	7645
80	3	527.1	15093	598.7	17276	662.7	19239	722.2	21044
100	4	801.1	22942	910	26260	1008	29243	1098	31986
150	6	2109	60375	2395	69107	2651	76989	2889	84176
200	8	3956	113296	4494	129681	4974	144410	5421	157958
250	10	6331	181300	7191	207519	7959	231089	8675	252769
300	12	8607	246491	9777	282138	10821	314183	11794	343658

Table 8-15: Measuring range for saturated steam: 150...300 psig







KROHNE – Products, Solutions and Services

- Process instrumentation for flow, level, temperature, pressure measurement and process analytics
- Flow metering, monitoring, wireless and remote metering solutions
- Engineering, commissioning, calibration, maintenance and training services

Head Office KROHNE Messtechnik GmbH
Ludwig-Krohne-Str. 5
47058 Duisburg (Germany)
Tel.: +49 203 301 0
Fax: +49 203 301 10389
info@krohne.de

The current list of all KROHNE contacts and addresses can be found at:
www.krohne.com

